

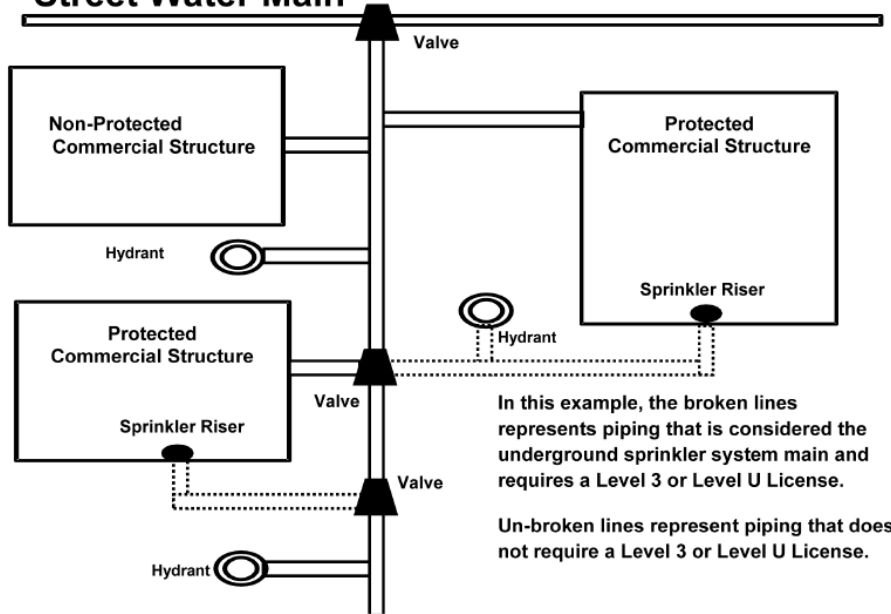

Commercial Example Street Water Main

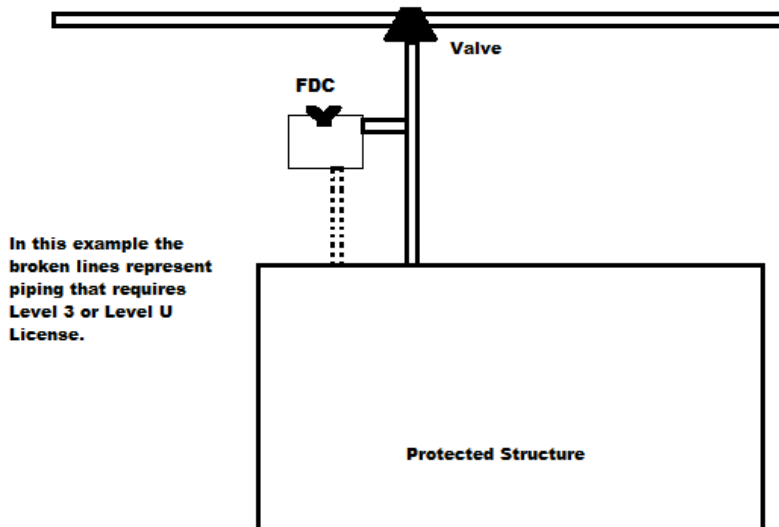

Street Water Main



Residential Example Street Water Main

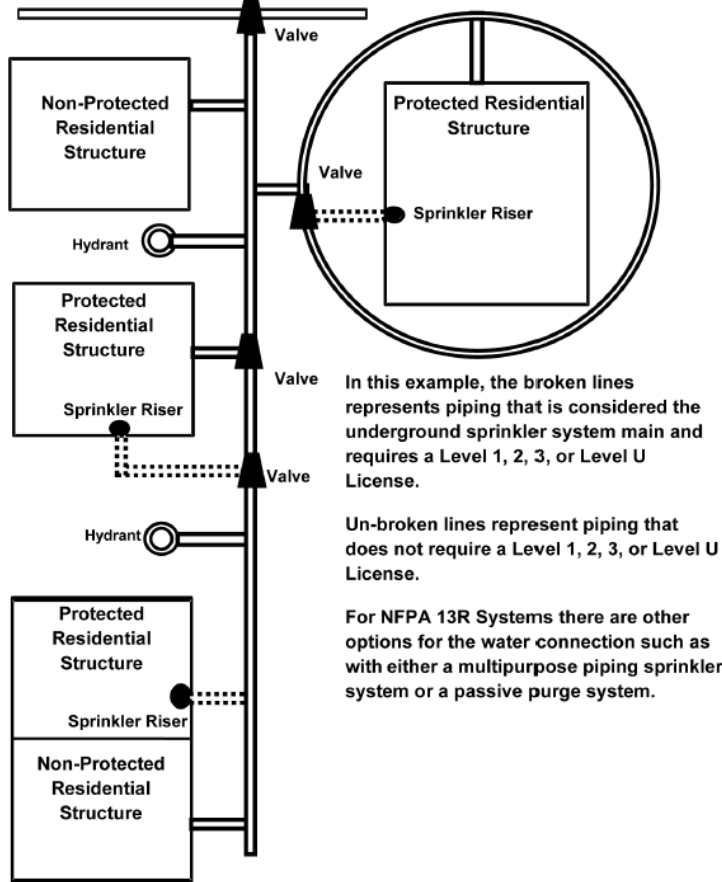

Street Water Main

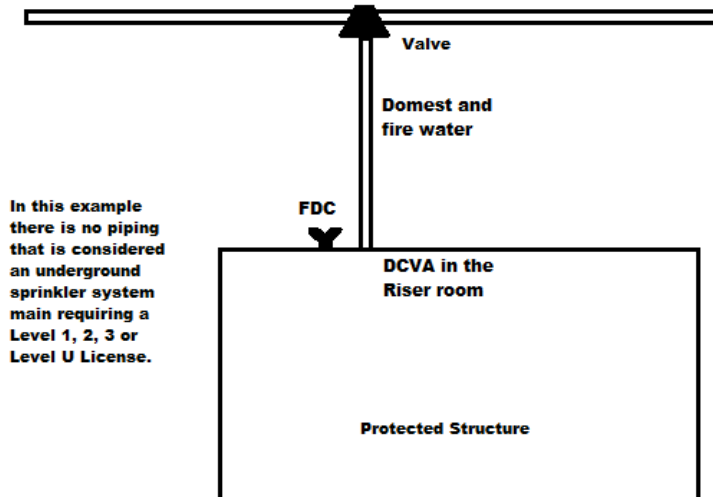

Street Water Main

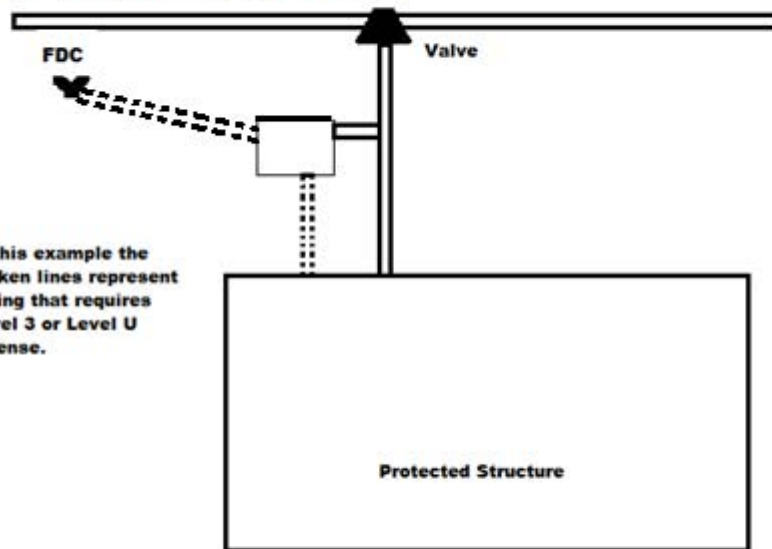

In this example the broken lines represent piping that requires Level 3 or Level U License.

Protected Structure