

Public Works Department
Wastewater Engineering - Collections

Public Sanitary Sewer Design and Construction Standards



January 2025

Contents

3-1 INTRODUCTION.....	1
3-1.01 Authority, Codes, and Standard Specifications.....	1
3-1.02 Proposal Review Requirements.....	2
3-1.03 Civil Plan Requirements.....	2
3-1.04 Service Lateral Table Requirements.....	3
3-1.05 Construction and Final Civil Project Acceptance.....	3
3-2 GRAVITY SEWERS	4
3-2.01 Location.....	4
3-2.02 Easements.....	4
3-2.03 Easement Vacations.....	5
3-2.04 Capacity.....	5
3-2.05 Slope.....	5
3-2.06 Design Flows.....	6
3-2.07 Pipe Materials.....	7
3-2.08 Pipe Diameter.....	8
3-2.09 Installation.....	8
3-2.10 Depth and Cover.....	8
3-2.11 Separation.....	9
3-2.12 Pipe Joints.....	9
3-2.13 Pipe End Connections.....	9
3-2.14 Anchor Walls.....	9
3-3 MANHOLES, CLEANOUTS, AND STUB-MARKERS.....	10
3-3.01 Location.....	10
3-3.02 Design Considerations.....	10
3-3.03 Drop Manholes.....	10
3-3.04 New Manholes over Existing Sewer Mains.....	10
3-3.05 Gravity Connections to Manholes.....	10
3-3.06 Frames, Covers and Steps.....	11
3-3.07 Sewer Main Stubs.....	11
3-3.08 Stub Markers and Cleanouts.....	11
3-3.09 Discharge Manhole Lining (Sealing) Requirements.....	11
3-3.10 Construction.....	12
3-4 SERVICE CONNECTIONS	12
3-4.01 Service Laterals (Side Sewers).....	12
3-4.02 Building Reconnection Requirements.....	13

3-4.03	Trenchless Methods for Service Lateral Construction and Repair	13
3-4.04	On-Site Plumbing (Private Building Sewers)	13
3-4.05	Private Easements for Private Sewers	14
3-4.06	Trenchless Methods for Private Building Sewers	14
3-4.07	Accessory Building Service Options	14
3-5	OTHER DESIGN AND CONSTRUCTION REQUIREMENTS	14
3-5.01	Phased and Contingent Development	14
3-5.02	Decommissioning Sanitary Sewer Mains and Appurtenances	14
3-5.03	Streams and Storm Facilities	15
3-5.04	Railroad Crossings	16
3-5.05	Hydraulic Modeling for Capacity	16
3-6	ALTERNATIVES TO GRAVITY SYSTEMS	16
3-6.01	Public Pump Stations	16
3-6.02	Shared Public Pressure Sewers	17
3-6.03	Public Pressure Sewer Design and Construction	17
3-6.04	Private Individual Grinder Pumps	17
3.7	INDUSTRIAL PRETREATMENT REQUIREMENTS	18
3-7.01	Industrial / Commercial Wastewater	18
3-7.02	Grease Removal Devices	18
3-7.03	Oil / Water Separators	18
3-7.04	System Development Charges	18
3-7.05	Prohibited Discharges	19
3-7.06	Gas Station / Fuel Center	19
3-7.07	Onsite Stormwater Runoff	19
3-7.08	Industrial / Commercial	19
3-7.09	Wastewater Hauling	19
3.8	SEWER CONNECTION INCENTIVE PROGRAM	19
3.9	RECORD DRAWINGS	20
3.10	GUARANTEES	20
3.11	SANITARY SEWER STANDARD DETAILS	21

SECTION 3

SANITARY SEWER DESIGN AND CONSTRUCTION STANDARDS

3-1 INTRODUCTION

The City of Vancouver's (City) Public Works Department provides wastewater collection and treatment for a service area of about 58 square miles. The area includes residential, commercial, and industrial customers, inside and outside of the City limits. The sanitary sewer collection system includes about 787 miles of piping. Piping is dedicated to wastewater and is separate from stormwater systems. Wastewater is delivered to two (2) facilities for treatment: The Westside and Marine Park Wastewater Treatment Plants.

3-1.01 Authority, Codes, and Standard Specifications

The City maintains the collection system in accordance with two (2) wastewater discharge National Pollution Discharge Elimination System permits issued by Washington Department of Ecology for the Westside and Marine Park wastewater treatment facilities. The City's system satisfies and follows Ecology's *Criteria for Sewage Works Design* (CSWD, Orange Book). The Growth Management Act requires collection systems to maintain a General Sewer Plan (GSP). The City's two volume GSP plan was prepared by Kennedy/Jenks Consultants in April 2011.

The Vancouver Municipal Code (VMC) requires developing properties to be served by public sewer. Developments are required to connect to existing public sewers and to construct public sewers to the site and across developing frontages. Construction through properties is also required to allow extensions for service to adjacent parcels. On-site public sewers are typically required to serve commercial and industrial complexes with multiple buildings serving separate owners and/or tenants. Public sewers are also required for sites with multiple residential buildings, such as apartments and condominiums (WAC 173-240-104).

Sewers shall be designed according to GSP sizes, elevations, alignments, and capacity requirements as necessary for the fair and orderly development of the system. Off-site downstream capacity studies and improvements may also be required. The VMC also regulates discharges of commercial and industrial wastes. Applicable code sections include VMC 14.04.280, 14.16.010, 14.10, 20.270.050, and 20.320.040.

In addition to these General Requirements and Details, construction of public sewers shall also conform to the current version of the *Standard Specifications for Road, Bridge & Municipal Construction* prepared by Washington State Department of Transportation and the Washington State Chapter of the APWA (Standard Specifications). These Standard Specifications are found on the WSDOT website ([Home > Engineering & standards > All manuals & standards > Manuals > Standard Specifications for Road, Bridge, and Municipal Construction](#)).

Finally, construction shall also conform to the *City of Vancouver Amendments to the most current WSDOT Standard Specifications for Road, Bridges and Municipal Construction (Water, Sanitary Sewer, and Surface Water Construction Amendments)*.

These General Requirements and Details and other resources are found on the City's [Sewer Design and Construction Requirements](#) web page. Contact Sewer Engineering staff for latest version. The Permit Center is located at City Hall (415 West 6th Street). The Engineering Services phone number is (360) 487-7804 and the email address is citycddeng@cityofvancouver.us.

3-1.02 Proposal Review Requirements

Proposals for new public sewer construction, improvements, and/or new individual services require City review. Developing properties typically submit a pre-application proposal to the Community Development Department. City requirements, including public sanitary sewer, are provided in a pre-application report. Information about the pre-application conferences is found on the [Land Use and Planning Applications](#) web pages. Additional requirements are included as conditions in the application's staff report.

Proposals and inquiries without land applications require submittal of a Request for Utility Service (utility review). Completed reviews provide the applicant with public sanitary sewer service and web page.

3-1.03 Civil Plan Requirements

All public sewer improvements require submittal of civil plans prepared, signed, and sealed by an engineer licensed in the State of Washington. Designs are required to address pre-application and utility review requirements, land entitlement (staff report) conditions, and the codes and standards. Civil plans associated with land applications are submitted and reviewed together with the land application. Plans without land entitlements are submitted and reviewed separately.

Civil plan submittal requirements are found on the Engineering Services web page. Civil plans are also required to include the following, where applicable:

- Plans, profiles, details, and grading plans for new or extended sanitary sewers, new manholes, and new stubs (eight (8) inch or greater).
- City Standard Plans that apply to the project.
- Special designs, installations or conditions may require additional notes.
- All existing and proposed easements with recording number and dimensions.
- All existing and proposed sanitary sewer mains/laterals and easements clearly identified as public or private.
- Sewer Specific stationing is required in plan and profile views on utility plans, beginning at station 0+00 at the downstream manhole. Stationing shall be based on the sewer centerline.
- All existing manholes and cleanouts labeled with the City-assigned identifier number.
- Pre-treatment structures, including manufacturer and capacity.
- Locations of existing septic tanks.
- Larger sites may require overall utility plan.

Plan review and approval is required prior to construction. Final civil plan sets shall address all City review redlines. An applicant's submittal for civil plan approval constitutes their agreement to construct all of the sewer facilities shown on the approved plans. Plan approval is a declaration that sewer construction as specified and conditioned will be consistent with the following requirements:

- Existing public sewers are available to serve the proposed development.
- The design satisfies the GSP, the VMC, and land entitlement conditions.
- Sewer construction is legally and physically buildable to specified standards.
- The design satisfies the WSDOT Standard Specifications, City Amendments to those specifications, these General Requirements and Details, and other applicable standards.
- Completed construction will be suitable for public ownership.

All design changes to approved plans require City review and approval.

3-1.04 Service Lateral Table Requirements

Each sewer service lateral shall be designed with upstream depths and elevations adequate for service to the intended lot or building, and to meet the minimum cover requirements.

Sanitary sewer designs in civil plan sets require service lateral tables. Lateral tables are required for both gravity and pressure laterals within public right-of-way or public sewer easement.

This section summarizes intent, provides requirements, and provides examples.

Table S-1. Example Sanitary Sewer Lateral Table

EXAMPLE SANITARY SEWER LATERAL TABLE										
Lot No.	Diameter & Material	Downstream Manhole	Dist. To Downstream MH (Ft)	Sewer Main IE	Length From Sewer Main (Ft)	Slope (Ft/Ft)	IE @ Property Line	Finished Floor Elevation (FFE)*	Cover @ Property Line (Ft)	Sewer Lateral Detail No.
X	X" PVC	MH #X	XX.XX	XXX.XX	XX.XX	0.XXXX	XXX.XX	XXX.XX	X.XX	S-1.4X

*FFE required only for laterals with five (5) feet or less of cover

The intent of lateral tables is to:

- Demonstrate that each lateral has been specifically considered and designed
- Show how upstream end elevations are calculated
- Compare upstream elevations to finish grades and/or finish floor elevations
- Identify applicable sewer standard details
- Pipe material and diameter
- Provide locations for direct comparison to construction inspections (CCTV) observations.
- Accommodate surveyed as-built information and provide clear and accurate records for permanent as-built records

Lateral tables shall include, at a minimum, the following columns:

- Lateral ID/building name
- Downstream manhole number
- Distance to downstream manhole
- Elevation of main at the connection
- Lateral diameter and material
- Slope (Note: Where applicable, slope shall be calculated as the upstream invert minus the downstream invert at the wye divided by the lateral length)
- IE at the upstream end (property line or edge of public sewer easement)
- Cover at upstream end
- FFE required on lateral table only for laterals with five (5) feet or less of cover

The following may also be required, where applicable:

- End location geometry notes (for angled laterals)
- Identify lots that require private pump systems.
- Minimum finish floor elevations
- Invert elevation and clearance over or under stormwater infiltration trenches

3-1.05 Construction and Final Civil Project Acceptance

Developments are required to construct all sewer improvements in accordance with City standards and as noted on the approved civil plans. Escrow provisions are not available for underground utilities.

Public sewer installations shall meet the testing and inspection requirements of Construction Services prior to receiving Construction Acceptance. To receive Final Civil Project Acceptance, the development shall meet the requirements itemized in the plan approval letter. Final Civil Project Acceptance is required prior to submitting a final plat and/or sewer connection permit applications.

3-2 GRAVITY SEWERS

This section contains information and guidelines for the design of public gravity sewers within the City's public right-of-way or public sewer easements.

3-2.01 Location

Whenever possible, public sewers shall be extended in public right-of-way. Sewer shall be located south or west of centerline in the center of the travel lane.

3-2.02 Easements

Public sewers that are not located in the public right-of-way must be in a public sewer easement dedicated to the City. Easements allow direct access for maintenance by City staff. Public sanitary sewer maintenance access is provided by the public sewer easement language and/or VMC 14.04.035. Easements shall use standard required language and exhibits. Language is available on the Engineering Services web page.

Completed easement documents shall be submitted to the City for recording. Questions regarding easements can be directed to Engineering Services. The developer may also be required to submit easement release documents to Sewer Engineering for review and approval. Only the City can record public sewer easements.

Ingress/egress and utility easements are not an acceptable substitute for a required dedicated public easement to the City of Vancouver.

Public utility easements may be recorded by plats when associated with land divisions within the City limits. Plat recordings must include standard dedication language.

In cases where off-site sewers require public easements, submittal of recordable easements is a condition of civil plan approval.

Sewer facilities that require easements on private property include, but are not limited to, sewer mains, manholes and clean-outs.

Easements shall be fifteen (15) feet wide or greater. Shared utility easements with sanitary sewer and one other public utility such as water or storm water shall generally be a minimum of 20 feet wide. Shared utility easements with sewer and two other utilities shall generally be a minimum of 25 feet wide. Wider easements may be required depending on the depth and size of the utilities. The easements shall extend at least ten (10) feet past the end of the main. Sewer mains shall be located at least five (5) feet inside the edge of the easement.

Easements shall be located entirely on one parcel. Straddling lot lines will not be allowed. There shall be no structures, including trees, overhanging objects including roofs, fences, retaining walls, or building foundations located within the sewer easement (VMC 14.04.140N).

Storm facilities located within sewer easements shall be consistent with Section 3-5.03.

All existing and proposed public sewer easements shall be shown, noted, and specified on civil plans,

site plans, landscaping plans, and plats.

Public sewer easements may also be required to provide direct maintenance access from the public right-of-way across private property to all parts of existing or proposed public sewer easements and facilities, or as needed for access to adjacent lots with public sewer. Direct access shall be designed, specified, and maintained for heavy maintenance vehicles (Sewer Detail S-6.1). An approved turnaround for maintenance vehicles shall be required for access roads over 150 feet in length.

The largest sewer maintenance vehicles require a turning radius of over 40 feet. Users of AutoTurn software and Autodesk's Vehicle Tracking software can download a single zip file that contains drawing files for the current vector truck turning radius data. [AutoTurn Vehicle Information](#) and [vehicle tracking information](#)

3-2.03 Easement Vacations

Public sewer easements that are un-used or not needed anymore shall be vacated. Easement vacation requests are to be reviewed and approved by the City.

Recorded Plats shall be revised per VMC 20.320.080(D) and RCW 64.04.175.

If an easement vacation is deemed necessary, the developer shall submit a request to Sewer Engineering to vacate an existing easement or part of an existing easement. The developer shall submit the original easement along with the legal description and a map of the easement area to be vacated prior to Civil Plan Approval. City Council approval is required to terminate an easement. Development construction and occupancy may proceed prior to vacation.

3-2.04 Capacity

The flow rate of a sewer main is estimated using Manning's formula for open channel flow.

$$Q = (1.49/n)AR^{2/3}S^{1/2}$$

Where:

- Q = Flow rate in cubic feet per second
- n = Coefficient of roughness, 0.013 is used for sewer main design
- A = Cross-sectional area of flow in square feet
- R = Hydraulic radius (Area divided by wetted perimeter) in feet
- S = Slope of the hydraulic gradient in feet per foot

Peak discharge for sloped circular sewers under the force of gravity occurs when the fluid level is about 93 percent of the diameter. These design standards define pipe capacity as the discharge at full pipe. See Table S-2 for required minimum slopes and resulting pipe capacities.

Flow rates for sewer are commonly expressed in million gallons per day (mgd). Multiply cubic feet per second (cfs) by 0.6463 to convert to million gallons per day (mgd = cfs x 0.6463).

3-2.05 Slope

Table S-2 shows minimum pipe slope requirements. The first column lists common nominal pipe diameters. Middle columns specify minimum design and allowable as-built slopes. Design slopes for larger pipes are determined on a case-by-case basis.

Minimum Slope Calculation: Slopes shall be based on linear feet between the center of a manhole to the center of the adjacent cleanout or manhole. Linear feet of pipe shall be based on the center-to-center distance between adjacent manholes or cleanouts.

Minimum Design Slopes: Engineers shall design systems using the minimum design slopes in most cases. In general, steeper slopes are desirable and are recommended where the main will not be extended further and there are few connections.

Minimum as-built slopes are based on slopes required to produce a mean velocity of at least two (2) feet per second (fps) when flowing full or half full using a Manning's coefficient of 0.013. The differences between design slopes and as-built slopes in Table S-2 represent an allowable tolerance of 0.0005. Mains installed flatter than the as-built minimum shall be re-installed by the contractor to meet the minimum requirements.

Maximum Allowable Slope: Maximum pipe slope shall be governed by terrain and available fall between manholes. Maximum velocity in the pipes shall not exceed eight (8) fps, unless specifically approved by the City. In some cases, it may be necessary to use drop connections to reduce slope and velocities.

Table S-2. Minimum Slopes and Pipe Capacities

Inside Diameter (inches)	Minimum Pipe Slope (ft\ft)		Pipe Capacity at Minimum Design Slope (mgd)
	Design	As-Built	
8	0.0045	0.0040	0.50
10	0.0033	0.0028	0.75
12	0.0027	0.0022	1.1
15	0.0020	0.0015	1.6
18	0.0017	0.0012	2.4

Notes:

- Mains installed flatter than the as-built minimum shall be re-installed by the contractor to meet the minimum requirements.
- Pipe capacities are defined at full pipe.
- Pipes larger than eighteen (18) inches require review and approval.

3-2.06 Design Flows

Design flow calculations typically include estimates of average, maximum, and minimum daily flows. The submission of design calculations will not ordinarily be required, but engineers should be prepared to substantiate pipe sizes, layout, population estimates, land uses, fixture units, and other design assumptions.

The sanitary sewers shall be designed with the capacity to handle peak flows at full pipe and to transport suspended solids during low flows. Average design flows are determined by the following factors:

- Drainage basin characteristics
- Population densities
- Per capita wastewater contribution rates
- Land use within the area to be served.
- Commercial, industrial, or institutional users to be served.

Average Baseflow: Values in Table S-3 on the next page are approved to estimate the average buildout baseflow. Alternate estimates can use flow monitoring data or other reliable industry-standard rates. Alternate estimates require comparisons to the rates in Table S-3.

Table S-3. Sanitary Sewer Contribution Rates

Type	Average Flow
Residential	75 gpd/person
Commercial	800 gpd/acre ⁽¹⁾
Industrial	800 gpd/acre ⁽¹⁾
Infiltration and Inflow	200-2000 gpd/acre ⁽²⁾

(1) Based on total site acreage

(2) Estimates vary by basin

Peaking Factor (PF): The formula below is approved to calculate the baseflow’s peaking factor.

$$PF = 2.63 - 0.26\ln(Q_{ave}\text{-mgd})$$

Infiltration & Inflow (I&I): Groundwater and rainfall-related inflows sometimes enter sanitary sewers. Sewer designs must estimate and account for I&I. Estimates vary by basin and are maintained by the Sewer Engineering office (and General Sewer Plan).

Required Pipe Capacities shall accommodate total peak buildout flows according to the following formula:

$$\text{Required Pipe Capacity} = Q_{ave} \times PF + I\&I$$

Where:

PF = Peak Flow Factor

I&I = Infiltration and Inflow

3-2.07 Pipe Materials

All public sewer piping material and construction shall conform to the Standard Specifications. Table S-4 below specifies approved pipe materials.

Table S-4 Approved Pipe Materials and Specifications

Approved Material	Specifications
Polyvinyl Chloride (PVC) 4" to 15"	ASTM D 3034, SDR 35, or AWWA C900 (DR18 min, Green)
Polyvinyl Chloride (PVC) 18" or greater	ASTM F 679, Type 1 or AWWA C905 (DR 18 min).
Concrete Sewer Pipe (CSP) Non-reinforced	ASTM C 14, Class 2, or 3
Reinforced Concrete Pipe (RCSP)	ASTM C 76 Class III, IV, or V
SaniTite HP; 12"-30" Polypropylene dual wall	ASTM F2736
SaniTite HP; 30"-60" Polypropylene triple wall ⁽¹⁾	ASTM F2764

Notes:

- PVC pipe shall be installed in fourteen (14) feet maximum lengths without specific approval.
- Concrete sewer pipe requires City approval.
- CSP and RCSP are rigid pipe. Follow Sewer Details S-1.1.
- PVC, and SaniTite HP are flexible pipe. Follow Sewer Detail S-1.2.
- See table S-5 on page 17 for approved pressure sewer pipe materials.

Wyes and fittings shall be of the same size and material as the new sewer main. Laterals connecting to existing sewer mains of ductile iron or C900, shall be constructed of C900 (DR 18 min).

Pipe materials for special uses (such as for liner pipe, temporary construction, stream crossings, and bridge crossings) will be considered special design cases. These designs might include materials proposed for temporary construction, bridge crossings, and others. Submit civil plans detailing proposed material types, installation procedures, and specifications for approval through the engineering plan review process.

3-2.08 Pipe Diameter

Public sanitary sewers shall be a minimum of eight (8) inches inside diameter. Sewers shall not be reduced in diameter when the slope in the downstream section is increased except when approved by the City.

In certain cases, the City may require a sewer main that is larger than needed by the development alone. If the required main is twelve (12) inches or larger in diameter, then the City may contribute funds for the required material. See VMC 14.04.280(G). A cost sharing agreement must be approved prior to Civil Plan Approval.

3-2.09 Installation

Installation of sewer pipe shall conform to Sections 7-17.3 and 7-18.3 of the Standard Specifications and its Amendments. PVC pipe shall also be installed in accordance with UNI-BELL specification UNI-B-6-98. Water settling of backfill material is prohibited.

3-2.10 Depth and Cover

All public sanitary sewers shall be laid at a depth sufficient to be protected against damage by frost and traffic. Public sewers laid in areas subject to wheel loads shall have a minimum cover of five (5) feet measured from top of pipe to finished grade or be otherwise protected from damage by traffic. This minimum cover may be reduced to three (3) feet provided C900/905 (DR 18 min) pipe is used. In addition, mains in roadways, right-of-way, or other paved areas must be deep enough to accommodate proposed and future laterals with a minimum clearance between the top of the lateral and the bottom of the roadway section of at least six (6) inches.

Plans proposing lateral cover of five (5) feet or less shall specify minimum finished floor elevations (FFE). Indicate lots that require minimum finish floor elevations on site plans and plats. Include brief notes referring to the civil record drawings. Remaining laterals requirements are specified in Section 3-4.01.

Depths are defined as the distance from the main or lateral invert to the finished grade directly above.

Cover is defined as the distance from the top of the main or lateral to the finished grade directly above.

Under normal conditions public sewers in residential areas without basements should be laid at a depth of eight (8) feet. Service laterals to adjacent properties should be laid at a depth of at least six (6) feet at the property. Plans with public sewers less than six (6) feet deep shall show minimum building finished floor elevations (FFE) on all adjacent parcels. In residential areas with basements, public sanitary sewers shall be of sufficient depth to serve existing basements, if possible. Parcels with basements that cannot be reasonably served by gravity sewer shall be clearly indicated on the plans.

3-2.11 Separation

Sanitary sewers shall be a minimum of 50 feet from any well, spring, or other source of domestic water supply. All sanitary sewers or parts thereof which are located within 50 feet from any such source of domestic water supply shall be constructed of C900 (DR 18 min). Public sanitary sewer mains and domestic water mains shall not be laid in the same trench.

Follow Ecology's *Criteria for Sewage Works Design* (CSWD, Orange Book) for separation of sewer and water mains (Section C1-9.1). Paragraphs below repeat some of the parallel and perpendicular criteria. See Sewer Detail S-6.2 for pipe separation requirements.

Parallel Pipes: A minimum horizontal separation of ten (10) feet between gravity sanitary sewers and any existing potable water lines shall be maintained, whenever possible. The sewer shall also be a minimum of eighteen (18) inches below the water main. The distance shall be measured edge to edge. When physical conditions render this spacing impossible or impractical, a gravity sewer may be laid closer than ten (10) feet provided the elevation of the crown of the gravity sewer is at least eighteen (18) inches below the invert of the water line. When these separations cannot be obtained, the gravity sewer shall be constructed of approved pressure rated pipe with a minimum eighteen (18) foot length of pipe centered on the water main.

Perpendicular Pipes: Sewer lines crossing water lines shall be laid below the water lines to provide a separation of at least eighteen (18) inches between the invert of the water pipe and the crown of the sewer, whenever possible. If this is not possible, then the sewer main shall be constructed of approved pressure rated pipe with a minimum eighteen (18) foot length of pipe centered on the water main.

Sewer laterals without the clearance from water mains shall be constructed of approved pressure-rated pipe. Where the sewer line is above the water main, a minimum eighteen (18) inches of clearance is required in addition to the above requirements (Sewer Detail S-6.2).

Separation requirements are for the normal conditions found with sewage and water systems. These basic requirements apply to sewers of 24-inch diameter or less. Larger sewers may have additional requirements because of flow volumes and joint types. More stringent requirements may be necessary in certain conditions and in areas of high ground water or unstable soil conditions. For separation with storm sewers refer to Section 3-5.03.

3-2.12 Pipe Joints

All pipe joints must be watertight. Rubber rings or other approved joint sealing material shall be used. Any approved joint deflections in pressure sewer mains shall be controlled such that the watertight integrity of the joint is maintained. See Standard Specifications Section 7-08.3(2)E (Rubber Gasketed Joints) for requirements.

3-2.13 Pipe End Connections

Extensions connecting to existing PVC spigot ends of the same diameters require injection molded, factory welded, and fully gasketed (PVC GXG) fittings according to Standard Specifications Section 9-05.12 (1). When manholes cannot be installed and when specifically approved by the City transition connections between dissimilar materials shall only be made with approved adaptors (Fernco strong-back sheer band, Fernco Hulk, Romac, MaxAdaptor, or approved equal).

3-2.14 Anchor Walls

Sewer mains with slopes of 20 percent or greater shall be secured by anchor walls. Minimum anchor wall requirements are shown on Sewer Detail S-1.5.

3-3 MANHOLES, CLEANOUTS, AND STUB-MARKERS

Manholes, cleanouts, and stub markers provide access to safely inspect and maintain the City's sanitary sewer system. Below describes design and construction requirements for these structures.

3-3.01 Location

Manholes are required at the following locations:

- Changes in slope or alignment
- Changes in size or pipe material
- Each sewer main intersection or junction
- Upstream ends of mains longer than 150 feet
- At intervals of 400 feet or less (unless otherwise approved)
- Existing and future roadway alignments
- Lateral connections to mains if lateral diameter is greater than six (6) inches.

3-3.02 Design Considerations

The minimum inside diameter for a manhole is 48 inches. Manholes that require drop connections shall be a minimum diameter of 60 inches per Sewer Detail S-2.5A. Special cases may require manholes greater than 60-inch. Manholes built over large diameter sewers require special construction. Refer to the most current year Standard Specifications Section 7-05 (Manholes, Inlets, Catch Basins, and Drywells).

Provide a 0.2 foot minimum and 0.4-foot maximum drop in flow line elevation through manholes. The drop may be reduced to 0.1-foot for straight through manholes. Where a smaller sewer joins a larger one at a manhole, match crowns of the sewer pipes.

Connections to manholes, whether existing or new construction, shall be designed and constructed to provide a smooth transition of flow and have minimum interference with sewer hydraulics and access.

3-3.03 Drop Manholes

City approval is required for all connections entering a manhole at a distance 24-inches or greater. Inside drop assemblies are required for all main sizes and will require a 60-inch diameter manhole per Sewer Detail S-2.5A.

In special cases, drop connections with a pipe diameter of eight (8) inch or less entering a manhole less than 24-inches and greater than eighteen (18) inches shall be constructed with a beaver-slide drop per Sewer Detail S-2.5B. Drop connections to existing 48-inch manholes require approval from Sewer Engineering.

3-3.04 New Manholes over Existing Sewer Mains

New manholes constructed over an existing sewer main require Sewer Engineering approval. If the existing sewer main material is PVC or clay pipe, a new manhole shall be constructed per Sewer Detail S-2.1D. If the existing pipe material is concrete, follow Sewer Detail S-2.1C.

New manholes over existing sewer mains that have been CIPP lined require Sewer Engineering approval, epoxy lining, and CCTV inspection per Sewer Detail S-2.1E.

3-3.05 Gravity Connections to Manholes

A maximum of four (4) laterals per manhole, eight (8) inch min core edge to edge clearance required. Laterals connecting to manholes shall enter the manhole at bench elevation, and transition to the flow line. Laterals connecting to end of sewer main manholes require a minimum 0.3-foot drop. Inside drops for service laterals require approval from City.

New sewer mains or lateral connections that enter an epoxy coated or cementitious lined manhole, shall reline the entire manhole circumference one (1) foot up and down from the edge of the new core. Refer to section 3-3.09 and Sewer Detail S-5.5 for epoxy coating requirements.

New connections to brick manholes will not be allowed without City approval, connection to epoxy lined brick manholes shall not be permitted.

3-3.06 Frames, Covers and Steps

Frames, covers, and steps shall meet the requirements of Sewer Details S-2.1, S-2.2 series, and S-2.3. Grade adjustments shall require concrete riser rings located below the frame. Cover type shall be as follows:

- Standard frame and lid for all paved public right of way, see Sewer Detail S-2.2A.
- Locking frame and lid for unimproved areas or within remote easements, see Sewer Detail S-2.2B.
- Pamrex frame and lid for manholes installed within the 100-year flood plain or where storm water may accumulate, see Sewer Detail S-2.2C.
- Composite lid and frame for locations with high H₂S (hydrogen-sulfide) and odor issues, see Sewer Detail S-2.2D.

Steps shall be wide enough for a worker to place both feet on a step and shall have slip prevention. Steps shall be spaced at vertical intervals between twelve (12) and sixteen (16) inches. See Sewer Detail S-2.3.

3-3.07 Sewer Main Stubs

Sewer main stubs are required for future street alignments, service to adjoining parcels, and other locations needed for future basin development. Stubs shall be a minimum one (1) full stick of pipe extending from a manhole. Alignment shall be parallel to a future road centerline and/or perpendicular to the receiving sewer main. Piping shall typically extend to a property line, right-of-way, and/or beyond road improvements. Stub piping shall be laid at minimum slope, see Table S-2.

Existing sanitary stubs less than one standard stick of pipe shall be removed and replaced prior to extension. Pipe condition and slope on longer stubs shall be field verified.

3-3.08 Stub Markers and Cleanouts

Upstream ends of public sewer main stubs shall terminate with a stub marker. Stub markers may also be required on service laterals or if the sewer is less than 250 feet long and will be extended in the future. Stub markers are not approved substitutes for manholes or in other mid-run locations. See Sewer Detail S-3.0.

Cleanouts are allowed on upstream ends of sewers less than 150 feet long and that also have accessible downstream manholes. Cleanouts are not approved substitutes for manholes. See Sewer Detail S-3.1.

3-3.09 Discharge Manhole Lining (Sealing) Requirements

Both new and existing manholes receiving discharges from public pump stations, shared public

pressure sewers, or private pump systems serving commercial or industrial properties require lining (sealing). The receiving manhole and the next downstream manhole shall be lined. Additional manhole lining may also be required. Lining material shall be Raven 405 ultra-high build, 100% solids based, epoxy coating or an approved equal. Minimum thickness shall be 125 mils. Equipment, preparation, application, and curing shall satisfy manufacturer specifications and requirements. See Sewer Detail S-5.5. Pull testing is required by a third party, and shall be submitted to the City for approval.

3-3.10 Construction

Precast concrete manholes, including grade rings, are to be infused with Anti-Microbial Induced Corrosion additive (Con MicShield, Con-Block or approved equal) at the time of production. A color additive other than grey is required to provide a visual identification of treated manholes.

A watertight frame and cover shall be used if groundwater or surface drainage can be expected to flood the top of a sanitary manhole. A 100-year storm shall be used in determining flooding elevations. The manhole joints and frame shall be sealed with manufactured seals such as the external "Seal Wrap" system (Infi-Shield), Wrapid Seal, or approved equal. See Sewer Detail S-2.6. Watertight frame and cover assemblies are required for sanitary sewer manholes installed within the 100-year flood plain or where storm water may accumulate according to Sewer Detail S-2.2C.

There shall be flexible connections provided at the inlets and outlets of each manhole in the form of an expansion type rubber boot. Sand collars will not be accepted without specific approval from the City. See Sewer Detail S-2.4.

Connections to manholes, whether existing or new construction, shall be designed and constructed to provide a smooth transition of flow and have minimum interference with sewer hydraulics and access.

Cones, frames, and covers shall be rotated to avoid anticipated wheel traffic and gutters.

ijni

3-4 SERVICE CONNECTIONS

This section covers all design and construction requirements for service connections to the City public sanitary sewer system.

3-4.01 Service Laterals (Side Sewers)

Sanitary service laterals extending from the public sewer main to the property line to serve individual parcels and /or buildings shall be constructed and inspected to public standards. Each building on a parcel shall be served by a separate service lateral. Mixed-use buildings require separate service lateral connections for the separate uses. Separate system development charges will apply.

Connection, ownership, and responsibilities for service laterals are outlined in VMC 14.04.100 and VMC 14.08.50. On-site plumbing from the property line to the building is private and discussed in Section 3-4.04. All lots created by a Plat or binding site plan will require their own service lateral per VMC 20.320.070.

Sanitary service lateral connections to the public sewer main shall be installed according to Sewer Detail S-1.4A. All laterals are required to be laid at an adequate depth to serve the entire lot. Lateral construction shall conform to the same standards as for main sewer construction. If laterals are directional drilled, HDPE (DR 17 min) pipe with solvent welded joints is allowed. All laterals connecting to ductile iron pipe shall also be constructed of C900 (DR18 min) or ductile iron.

Sanitary service laterals in the public right-of way or public sewer easement shall be a minimum of six (6) inches in diameter. In the case of a single-family residence on a parcel zoned low density residential a minimum four (4) inch diameter lateral is acceptable. Service laterals shall be laid at a minimum slope of two (2) percent A slope of one (1) percent may be approved for unusual conditions provided a six (6) inch lateral is installed. Approval is required for any service laterals greater than six (6) inches.

Service laterals may be connected to manholes if such placement does not interfere with other present or future connections to the manhole.

The following service lateral connections and/or locations require City approval:

- Laterals connecting to manholes on large mains may be placed in the same easement as the sanitary interceptor where necessary.
- Pressure sewers from grinder pumps
- New service laterals or existing lateral repairs by trenchless methods.
- New laterals greater than six (6) inches in diameter.

Refer to Section 3-1.04 for lateral table requirements.

3-4.02 Building Reconnection Requirements

Reconnection of new or existing lots and buildings may be required to eliminate existing or proposed public or private sanitary sewer easements. Building plumbing reversal may also be required.

3-4.03 Trenchless Methods for Service Lateral Construction and Repair

Trenchless methods are generally approved for service lateral repairs (including the connection at the public main and piping within the right-of-way or public sewer easement). Lateral repairs in the right-of-way are subject to public construction standards, Engineering Services reviews, and Construction Services testing and inspections.

See the City's trenchless lateral repair webpage for more information: [Trenchless Service Lateral Repair Information | City of Vancouver, Washington, USA](#)

3-4.04 On-Site Plumbing (Private Building Sewers)

On-site building sewers are private and governed by the Building Department's plumbing code (UPC), along with other applicable local and state requirements.

Roof runoff, surface water, foundation drainage, and all other stormwater discharges to public sanitary sewers are prohibited.

Commercial and industrial complexes serving multiple owners or tenants, and multiple residential dwelling facilities (such as apartments and condominiums) in some cases require on-site public sanitary sewers (WAC 173-240-104).

Campus Provision allows for shared private on-site building sewers for certain qualifying non-residential, industrial, or commercial parcels (WAC 173-240-104). Qualifying parcels shall not be dividable or likely to divide. The parcel must not require construction of public sewer through the site to provide service to other parcels. Buildings and parcels shall be owned, and business operated under a single ownership. Qualifying parcels include, but are not limited to, hospitals, public schools,

and municipal facilities. Private sewers can serve multiple buildings as allowed by the plumbing code. Parcels can connect with a single service lateral connected to a dedicated public manhole. Other conditions may also apply.

3-4.05 Private Easements for Private Sewers

Building sewer easements across adjoining parcels will only be approved for situations where no other feasible service options exist (UPC 721). Building Department and/or Sewer Engineering review is required prior to easement signatures and recording. Private easement recordings are required prior to civil plan approval and issuance of construction and connection permits.

3-4.06 Trenchless Methods for Private Building Sewers

All on-site building sewers are private and governed by the Building Department's plumbing code. Plumbing permits and inspections are required. Plumbing permit jurisdiction ends at the property line. Repairs on the service lateral piping within the right-of-way require Public Works permits and Construction Services inspections according to Section 3-4.03.

3-4.07 Accessory Building Service Options

Accessory buildings and Accessory Dwelling Units (ADU) have two service connection options. If the accessory building's water is supplied by the parcel's main building, then the accessory building can connect to the main building's private on-site sewers. If each building has its own water meter, then the main building and accessory building shall have separate service lateral connections to the public main. This separate arrangement will trigger connection (SDC) charges (VMC 14.04.235).

Future land divisions that convert an ADU as a SFR on their own parcel will require separate service lateral connections.

3-5 OTHER DESIGN AND CONSTRUCTION REQUIREMENTS

This section contains information and guidelines for unique project specific considerations that come up during design.

3-5.01 Phased and Contingent Development

Civil plans can propose upstream sewers that depend on downstream sewer construction according to the following two (2) ownership situations:

1. Upstream Projects Proposed by Different Property Owners: Upstream civil plan approval requires downstream Construction Acceptance and final civil project acceptance. An option is to include complete downstream sewer designs in the upstream civil plans.
2. Phases Proposed by Same Property Owner: Upstream phases owned and constructed by the same developer require both contingent civil plan approval and contingent final civil project acceptance. Civil plan approval of an upstream phase requires civil plan approval of the downstream phases. Also, final civil project acceptance of an upstream phase requires civil project acceptance of downstream phases.

3-5.02 Decommissioning Sanitary Sewer Mains and Appurtenances

Prior to decommissioning any existing sewer main, dye testing shall be performed to ensure all live connections have been transferred to the new sewer main. In most cases, the City will allow decommissioned sewer mains and appurtenances to be left in place if shown that they will be properly decommissioned according to Federal, State, and local health regulations or as directed by the City.

Sewer mains shall be decommissioned by plugging the ends with Portland Cement concrete after they are flushed. The concrete plugs shall extend into the pipe from the pipe ends a minimum distance of three (3) times the inside diameter of the pipe. The Portland Cement concrete shall meet the requirements for Commercial Concrete, WSDOT/APWA, and most current version of the Standard Specifications Section 6-02.3(2)B. The space between the plugged ends of the abandoned main shall be required to be filled with sand or a pumpable, flowable cement slurry. See Sewer Detail S-3.5.

Manholes shall be decommissioned by removing the cover, frame, riser rings, cone, or flat slab, and filling the manhole with compacted material. The parts removed from the manhole shall be disposed of according to Federal, State, and local health regulations or as directed by the City. The material shall meet the grading requirements for backfill for sand drains, WSDOT/APWA, and most current version of the Standard Specifications Section 9-03.13. The material shall be compacted to at least 95 percent of the maximum density value determined according to Section 2-03.3(14)D. The remainder of the hole, from the top of the compacted material to finished grade, shall be backfilled, paved and/or landscaped, as directed by the City, to match the surrounding pavement or landscaping. See Sewer Detail S-3.5.

Service connections not being used shall be decommissioned by installing a mechanical plug at the tee or wye, on the sewer main, or by installing a watertight patch on the main at the lateral-to-main connection point. See Sewer Detail S-3.4.

Manhole cores that are being abandoned or not used shall be filled with a cementitious grout. Additionally, a watertight patch applied to the interior side of the manhole.

Civil plans and record drawings must clearly indicate whether features are to be abandoned in place or removed.

3-5.03 Streams and Storm Facilities

Sewer mains and laterals entering or crossing under or over storm facilities shall be constructed of pressure rated pipe or PVC pipe installed in an approved casing. They shall be designed, constructed, and protected against anticipated hydraulic, physical, longitudinal, vertical, and horizontal loads, and erosion impacts.

Storm facilities crossing public sanitary sewer shall have the following requirements:

- Maintain adequate depth of cover over the sewer pipe.
- Pipes crossing under or over seepage trenches shall be constructed of PVC C900 (DR 18 min).
- Drywells are not allowed in sewer easements. If the outlet from a swale goes to a drywell, the flow must be piped to a drywell located outside of the sewer easement. Sanitary sewer manholes shall not be located in the swale. If unavoidable, special approval may be required. If approved, manhole rims must be placed high enough to prevent inflow and the manhole shall be watertight to prevent infiltration. The rim shall be raised using standard sections and a cone section. Riser rings shall not be allowed.
- Sanitary service laterals are not allowed in the swale.

Sewers laid on piers across ravines, streams, drainage ponds or swales shall be allowed only when it can be demonstrated that no other practical alternative exists. Sewers on piers shall be constructed in accordance with the above requirements for sewers entering or crossing under streams. Designs shall be submitted for review and approved on a case-by-case basis.

Additional permits may be required for stream crossings and may include shorelines management, state fish and wildlife, and other permits. The developer shall obtain all necessary permits prior to construction. Construction shall meet or exceed the following requirements:

- The top of all sewers entering or crossing streams shall be at a sufficient depth below the natural bottom of the stream bed to protect the sewer line. In general, this will be three (3) feet of cover or more.
- Less cover will be approved only if the proposed sewer crossing will not interfere with the future improvements to the stream channel.
- Sewers crossing streams should be designed to cross the stream as nearly perpendicular to the stream flow as possible and shall be free from change in grade.
- Sewer systems shall be designed to minimize the number of stream crossings.
- Sewers located along streams shall be located outside of the stream bed and sufficiently removed from there to provide for future possible stream widening and to prevent pollution by siltation during construction.
- Sanitary sewer manholes shall not be located in the swale. If unavoidable, special approval may be requested. If approved, manhole rims must be placed high enough to prevent inflow and the manhole shall be sealed to prevent infiltration. The rim shall be raised using standard sections and a cone section. Riser rings shall not be allowed.

Infiltration trenches shall be lower than existing adjacent sewer mains where possible. Horizontal separation between public sanitary sewer pipes and soil-confined drainage trenches shall be a minimum of five (5) feet edge-to-edge if the sewer main is less than ten (10) feet deep. A minimum separation of ten (10) feet edge-to-edge if the sewer main is greater than ten (10) feet deep. Vertical separation of more than eighteen (18) inches between this type of storm water trench and public sewer pipes, and other conditions, may also require a greater horizontal separation, see Sewer Detail S-6.2.

3-5.04 Railroad Crossings

Railroad crossing locations and alignments require early coordination with the City and Railroad. Permits or easements with annual fees are prohibited. The developer shall obtain and make full payment for all required railroad permits and easements early in the design process and prior to civil plan approval. Specify permit number and other permit details on the civil plans. Design and construct crossings according to railroad standards and permit requirements. Include a crossing detail on the civil plans specifying all construction requirements. Bored steel casing and cathodic protection are typically required. See BSNF rail permitting requirements here: [BNSF - Rail Permitting](#)

3-5.05 Hydraulic Modeling for Capacity

Proposed developments may be required to perform hydraulic model simulations. Cases may include proposals with higher flows, discharges to alternate basins, and locations where sufficient downstream capacity is not certain. If modeling is necessary, then minimum requirements will be provided in a utility review or pre-application report. Complete simulation results are required early in the development process. City review and approval is required prior to land application submittal.

3-6 ALTERNATIVES TO GRAVITY SYSTEMS

This section covers all design and construction requirements for public pressure sewers within the City's public right-of-way or public sewer easements.

3-6.01 Public Pump Stations

Construction of public pump stations may be necessary to serve low-lying or flat areas within the City's

service area. Areas are generally identified in the GSP. Pump stations are not allowed in areas that can be served by public gravity sewers. Pump station and force main design and other requirements are published in the City's [Public Sanitary Sewer Pump Station Design and Construction Standards](#).

3-6.02 Shared Public Pressure Sewers

Shared public pressure sewers are designed to serve multiple private grinder pumps. Shared (or common) public pressure sewers serve areas where gravity sewer is not required, or not available where a public pump station is not warranted. Proposals for shared public pressure sewer are reviewed on a case-by-case basis. Design calculations and other submittals are required prior to civil plan approval. See Sewer Details S-5.0 – S-5.5.

The minimum pressure sewer size shall be two (2) inch diameter. The minimum cover of the pressure sewer shall be three (3) feet. The shared public pressure sewer shall contain no bends greater than 45 degrees.

Any approved joint deflections in pressure sewer mains shall be controlled such that the watertight integrity of the joint is maintained. See Standard Specifications Section 7-08.3(2)E (Rubber Gasketed Joints) for requirements. Thrust blocks are not approved. Mechanically restrain all joints.

Test Stations shall be required at every horizontal bend in the pressure sewer main as well as every 450 feet. Test stations shall be shown and detailed on the engineering plans. Toning wire and marking tape are required, see Sewer Detail S-5.4.

Design the pressure sewer to minimize the number of high points along the profile. However, topographic considerations and the desire to minimize the depth of the pressure sewer may not always make this practical. Install a sewage combination air release valve at each high point. Note on the plans the rim elevations and IE's for the vault, as well as the manufacturer and model number. See City of Vancouver Pump Station Construction Standard Detail PS-2.5A.

3-6.03 Public Pressure Sewer Design and Construction

Table S-5 below lists approved pressure pipe materials. These materials are approved for shared public pressure sewers less than four (4) inches diameter.

Table S-5. Pressure Sewer Pipe Materials

Approved Material	Specifications (for pipes less than 4")
Polyvinyl Chloride (PVC)	Schedule 80
High Density Polyethylene (HDPE), PE 3408	ASTM D3035, PE:345434C & ASTM D-1248, type III, Class C, Category 5, grade P34, DR 17 min. (green stripe required)

3-6.04 Private Individual Grinder Pumps

Private pump systems are approved for service in the following cases:

- Where gravity service is not required to serve remaining basin properties
- Where gravity service is not available, planned, or feasible.
- To serve low-lying areas that do not warrant a public pump station.
- To serve areas where excessive depth would be required to reach the site.
- To eliminate public and private easements.
- To eliminate septic system in the immediate vicinity of identified special protection areas as

defined by VMC 14.26 ([Ch. 14.26 Water Resources Protection | Vancouver Municipal Code](#)).

Ownership and Maintenance: On-site grinder pumps and building (pressure) sewers are private and are governed by Building Department requirements. All on-site maintenance is the responsibility of the property owner.

Connection Requirements: Pressure lateral connections to an existing or new manholes are preferred. Parcels discharging to public gravity sewers require a gravity service lateral according to Sewer Detail S-5.6.

Plan Requirements: Specify private pump total dynamic head (TDH) requirements on the civil plans. Indicate lots that require private grinder pumps on related plats and site plans. Include brief notes referring to the civil record drawings.

Refer to Section 3-3.09 for discharge manhole lining requirements.

3.7 INDUSTRIAL PRETREATMENT REQUIREMENTS

Pretreating a waste stream serves to protect the treatment plant, protect the receiving stream, and protects workers, both in sewer operations and at the plant. Below are the City's industrial pretreatment requirements and guidelines.

3-7.01 Industrial / Commercial Wastewater

Pretreatment may be required to remove pollutants from industrial and commercial wastewaters. An Industrial Pretreatment review may be required to determine whether a pretreatment permit will be issued to conditionally authorize the discharge of process wastewater. Further requirements and guidance can be found in VMC 14.10 – Pretreatment Ordinance.

If process wastewater discharges to sanitary sewer are proposed, or if the industry is defined as “categorical”. According to the Code of Federal Regulations, 40 CFR 405 through 471, an [Industrial Information Form \(IIF\)](#) or other environmental survey form must be submitted to Industrial Pretreatment. If a permit is required, preparation and approval may take six (6) months. There is no fee for the permit. In some cases, a sampling manhole or other pretreatment devices may be required. Contact Industrial Pretreatment at (360) 487-7130 for more information regarding industrial permits.

3-7.02 Grease Removal Devices

Commercial establishments that discharge food grease to the sanitary sewer system shall install a grease trap or interceptor (see Sewer Details S-4.0 and S-4.1). The City shall approve the sizing, design, and plan for installation in accordance with the Uniform Plumbing Code and other City requirements. Minimum size for an interceptor shall be 1,000 gallons. Contact the City Grease Trap program at (360) 487- 8177.

3-7.03 Oil / Water Separators

Automotive shops and other commercial establishments which discharge wastewater containing petroleum-based oil or grease shall install an oil/water separator (see Sewer Detail S-4.2). The separator size, design and installation shall be in accordance with City and State standards. For more information, contact Industrial Pretreatment at (360) 487-7130. Indicate the Grease Trap and Oil/Water Separator makes and models on applicable civil, site, and building plans.

3-7.04 System Development Charges

For industrial users that plan to discharge over 4,000 gpd of process wastewater, an additional SDC may be assessed by Industrial Pretreatment. Guidance on non-domestic discharges from sources such as swimming pool water, mobile pressure washers, seepage haulers, trucked wastewater, and RV holding tank disposal is available from the Pretreatment/Wastewater Dept. at (360) 487-7130.

3-7.05 Prohibited Discharges

Prohibitions and regulations of wastewater discharges are addressed in the pretreatment ordinance (VMC 14.10, <https://vancouver.municipal.codes/VMC/14.10>) The following are some specifically prohibited discharges.

3-7.06 Gas Station / Fuel Center

No fuel shall be discharged into the public sewer mains. All fuel spillages shall be contained in a Dead-End Sump.

3-7.07 Onsite Stormwater Runoff

Discharge of storm runoff to the sanitary sewer is prohibited. Street, roof, or footing drainage shall be removed by a system of storm sewers as required by local building codes. Drainage from gas station island runoff is also prohibited.

3-7.08 Industrial / Commercial

Sewer customers shall not introduce or cause to be introduced into the treatment plant any pollutant or wastewater which causes pass-through or interference. Specifically, wastewater must not be toxic, flammable, explosive, excessively acidic or alkaline (pH <5.5 or >10). Discharge of solid or viscous material that could cause obstruction in the sewer piping is prohibited. Wastewater excessively high in temperature or biochemical oxygen demand (BOD) may not be discharged to the City sewer. Refer to VMC 14.10 – Pretreatment Ordinance to review all general and specific prohibitions.

3-7.09 Wastewater Hauling

Trucked or hauled wastewater is not accepted without special approval. Discharges from local environmental cleanup are the most commonly accepted hauled wastes. Wastewater characterizations, a special discharge permit, and approval from the Industrial Pretreatment workgroup are all required. Contact the Industrial Pretreatment workgroup at (360) 487-7130.

3.8 SEWER CONNECTION INCENTIVE PROGRAM

The City of Vancouver is working to protect and enhance the quality of our urban water resources, improve wastewater service, and eliminate environmental health problems. We recognize the quality of life in our community is enhanced with healthy rivers, streams, lakes and wetlands, and the importance of protecting our groundwater, the source of the local drinking water supply. The Sewer Connection Incentive Program (SCIP) was developed to help eliminate water quality and service problems from failing septic systems by replacing them with safe, public sanitary sewers.

This program provides for construction of sanitary sewers while offering easy and affordable financing to homeowners of single-family residences. The goal of the program is to protect our water resources and assist homeowners in removing septic systems, especially systems that are failing or aging.

The program includes a two-year guaranteed maximum sewer main line fee for timely connections, and an economical and comprehensive financing package for homeowners of single-family residences. Program details are found on the City's SCIP webpage.

<https://www.cityofvancouver.us/publicworks/page/sewer-connection-incentive-program-scip>

3.9 RECORD DRAWINGS

Engineers are required to prepare and submit accurate record drawings for all publicly constructed utilities. Pre-paving as-builts and final project record drawing submittals are both required. Prepare and submit according to Section 1-4.01 of the *City of Vancouver General Requirements for Water, Sewer, and Storm*.

3.10 GUARANTEES

All materials and workmanship are subject to a two (2) year warranty for sanitary sewer as provided in the Standard Specifications and the City Amendments to those Standard Specifications (See section 1-05.10 of the Amendments). The warranty period does not commence until all required construction items have been completed and accepted by the City.

3.11 SANITARY SEWER STANDARD DETAILS

S-1.1	Pipe Bedding Details (Rigid Pipe)
S-1.2	Pipe Bedding Details (Flexible Pipe)
S-1.3	Typical Trench Section
S-1.4A	Standard Service Lateral for New Mains
S-1.4B	Riser Lateral Connection
S-1.4C	Saddle Tapping Tee Connection
S-1.4D	Existing Service Lateral to New Mains
S-1.4E	New Service Lateral to Existing CIPP Main
S-1.5	Standard Anchor Wall
S-2.1A	Standard Pre-cast Manhole
S-2.1B	Top Slab Manhole
S-2.1C	Pre-cast Doghouse Manhole
S-2.1D	New Manhole Connection to Ex PVC Sewer Main
S-2.1E	New Manhole Over Existing CIPP Lined Sewer Main
S-2.2A	Standard Manhole Lid and Frame
S-2.2B	Locking Manhole Lid and Frame
S-2.2C	Pamrex (watertight) Manhole Lid and Frame
S-2.2D	Composite (Odor Control) Manhole Lid and Frame
S-2.2E	Adjustable Manhole Frame (Rim-Riser)
S-2.3	Standard Manhole Step
S-2.4	Standard Manhole Connection
S-2.5A	Standard Drop Connection
S-2.5B	Beaver Slide Drop Connection
S-2.6	Standard Manhole Joints
S-3.0	Standard Gravity Sewer Stub Marker
S-3.1	Standard Gravity Sewer Cleanout
S-3.2	RV Disposal Station – Commercial
S-3.3	RV Disposal Station – Residential
S-3.4	Sewer Service Lateral Abandonment
S-3.5	Sewer Manhole and Sewer Main Abandonment
S-4.0	Standard Grease Interceptor
S-4.1	Standard Indoor Hydromechanical Grease Interceptor
S-4.2	Oil / Water Separator
S-4.3	Elevator Sump Pump – w/ Oil Water Separator
S-4.4	Elevator Sump Pump – w/ Oil Sensing Alarm
S-5.0	Pressure Sewer Main Isolation Valve
S-5.1	Standard Pressure Sewer Cleanout
S-5.2	Toning Wire and Marking Tape
S-5.3	Standard Pressure Service Lateral
S-5.4	Standard Locating Test Station
S-5.5	Pressure Sewer Discharge Manhole
S-5.6	Pressure to Gravity Service Connection
S-6.1	Standard Sewer Easement Access Roads
S-6.2	Sewer Separation and Crossing Requirements

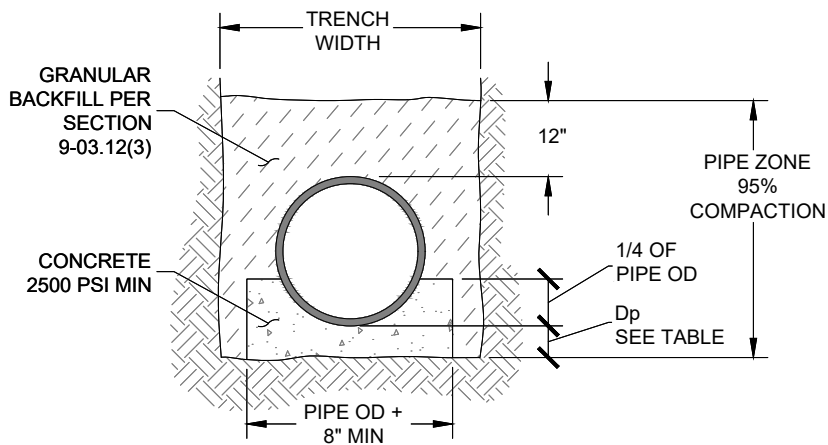

**CLASS A
CONCRETE CRADLE**

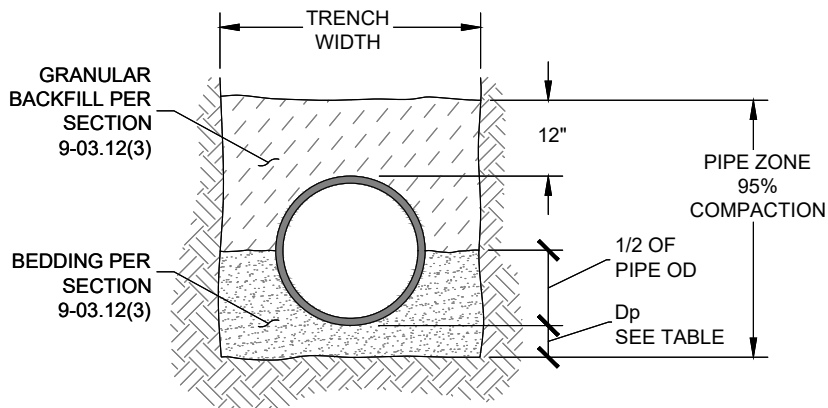

**CLASS B
GRANULAR FOUNDATION**

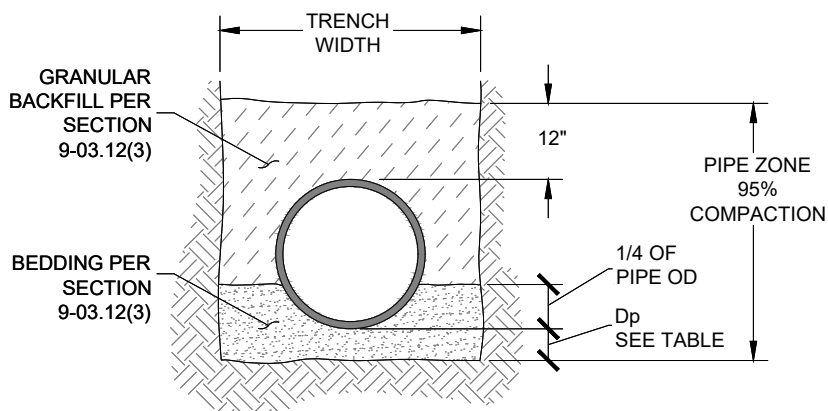

**CLASS C
GRANULAR FOUNDATION**

DEPTH OF BEDDING MATERIAL BELOW PIPE	
PIPE DIA	Dp (MIN)
27" & SMALLER	4"
LARGER THAN 27"	6"

NOTES

1. WHERE DIRECTED BY THE ENGINEER, GRANULAR TRENCH FOUNDATION STABILIZATION SHALL BE PLACED PRIOR TO PLACEMENT OF THE BEDDING. SIZE AND DEPTH ARE DEPENDENT ON SOIL CONDITIONS.
2. BEDDING AND BACKFILL MATERIALS IN THE PIPE ZONE SHALL BE COMPACTED AS SPECIFIED PRIOR TO BACKFILLING THE REMAINDER OF THE TRENCH.
3. FOR ROCK AND OTHER INCOMPRESSIBLE MATERIALS, THE TRENCH SHALL BE OVER-EXCAVATED A MINIMUM OF 6" AND REFILLED WITH GRANULAR MATERIALS AS DIRECTED BY THE ENGINEER
4. BACKFILL AND COMPACTION ABOVE THE PIPE ZONE SHALL BE INSTALLED AS SHOWN ON SEWER DETAIL S-1.3.
5. NATIVE MATERIAL MAY BE USED IN LIEU OF IMPORTED MATERIAL FOR BEDDING SPECIFIED, PROVIDED THAT THE NATIVE MATERIAL CONFORMS TO SECTION 9-03.12(3) OF THE STD SPECIFICATIONS, AND IS APPROVED BY THE ENGINEER. THE CONTRACTOR SHALL SUBMIT A SAMPLE OF THE NATIVE MATERIAL TO A GEOTECHNICAL ENGINEER FOR LABORATORY TESTING AND ANALYSIS. THE GEOTECHNICAL ENGINEER SHALL PROVIDE A REPORT OF THE SUITABILITY OF THE NATIVE MATERIAL FOR PIPE BEDDING PRIOR TO USE.
6. TRENCH WIDTH SHALL NOT EXCEED ONE AND ONE-HALF THE OUTSIDE DIAMETER OF THE PIPE PLUS 18" AT THE TOP OF THE PIPE ZONE.
7. FOR FLEXIBLE PIPE BEDDING SEE SEWER DETAIL S-1.2

N.T.S.



PIPE BEDDING (RIGID PIPE)		
CITY OF VANCOUVER DEPARTMENT OF PUBLIC WORKS SANITARY SYSTEMS PLANNING AND DESIGN		
DRAWN BY	APPROVED BY	APPROVAL DATE
BTC	SLH	01 - 2025
REVISION	APPROVED BY	APPROVAL DATE
-	-	-

SEWER
DETAIL NO.
S-1.1

DEPTH OF BEDDING MATERIAL BELOW PIPE	
PIPE DIA	Dp (MIN)
27" & SMALLER	4"
LARGER THAN 27"	6"

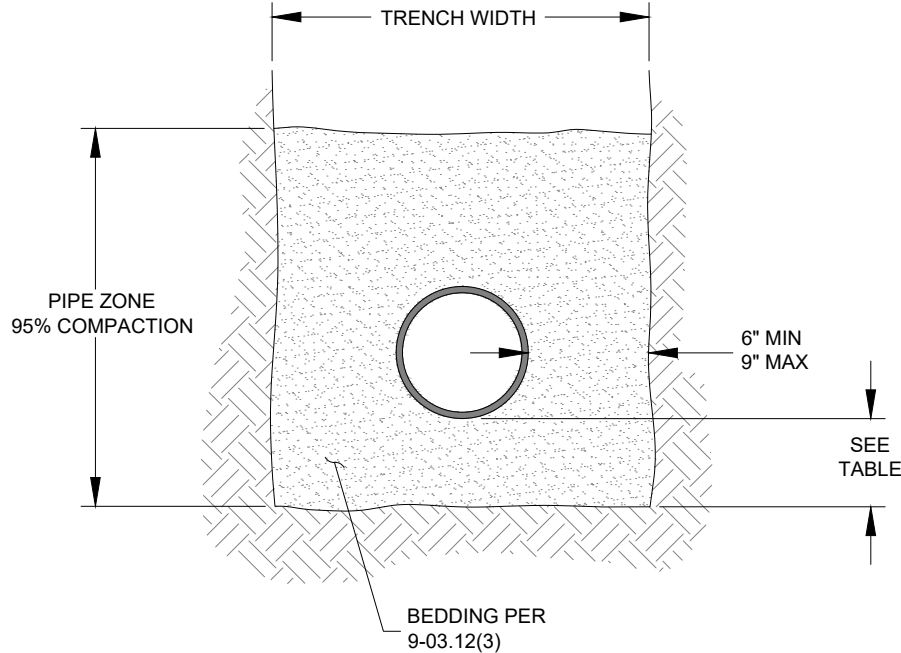

NOTES

1. WHERE DIRECTED BY THE ENGINEER, GRANULAR TRENCH FOUNDATION STABILIZATION SHALL BE PLACED PRIOR TO PLACEMENT OF THE BEDDING. SIZE AND DEPTH ARE DEPENDENT ON SOIL CONDITIONS.
2. BEDDING AND BACKFILL MATERIALS IN THE PIPE ZONE SHALL BE COMPACTED AS SPECIFIED PRIOR TO BACKFILLING THE REMAINDER OF THE TRENCH.
3. FOR ROCK AND OTHER INCOMPRESSIBLE MATERIALS, THE TRENCH SHALL BE OVER-EXCAVATED A MINIMUM OF 6" AND REFILLED WITH GRANULAR MATERIALS AS DIRECTED BY THE ENGINEER
4. BACKFILL AND COMPACTION ABOVE THE PIPE ZONE SHALL BE INSTALLED AS SHOWN ON SEWER DETAIL S-1.3.
5. INSTALLATION SHALL CONFORM TO SECTION 7.08 OF THE STANDARD SPECIFICATIONS EXCEPT AS NOTED. REFER TO THE UNI-BELL UNI-PUB-6 "INSTALLATION GUIDE FOR SOLID-WALL PVC SEWER PIPE" FOR RECOMMENDED CONSTRUCTION PRACTICES.
6. FINAL INSTALLATION TO BE TESTED PER SECTION 7-17.3(2)G OF THE STANDARD SPECIFICATIONS.
7. ALTERNATIVE PRE-COVER MATERIALS ARE ALLOWABLE FROM THE PIPE CENTERLINE TO ONE FOOT ABOVE THE TOP OF PIPE. ALTERNATE PRE-COVER MATERIALS MUST BE PRE-APPROVED BY THE INSPECTOR AND MAY BE SAND, CRUSHER SCREENINGS, GRAVEL, OR OTHER CLEAN GRANULAR MATERIAL CONTAINING NO ROCK LARGER THAN 1-1/4" IN LENGTH.

N.T.S.



PIPE BEDDING (FLEXIBLE PIPE)

CITY OF VANCOUVER
DEPARTMENT OF PUBLIC WORKS
SANITARY SYSTEMS PLANNING AND DESIGN

DRAWN BY	APPROVED BY	APPROVAL DATE
BTC	SLH	01 - 2025
REVISION	APPROVED BY	APPROVAL DATE
-	-	-

SEWER
DETAIL NO.
S-1.2

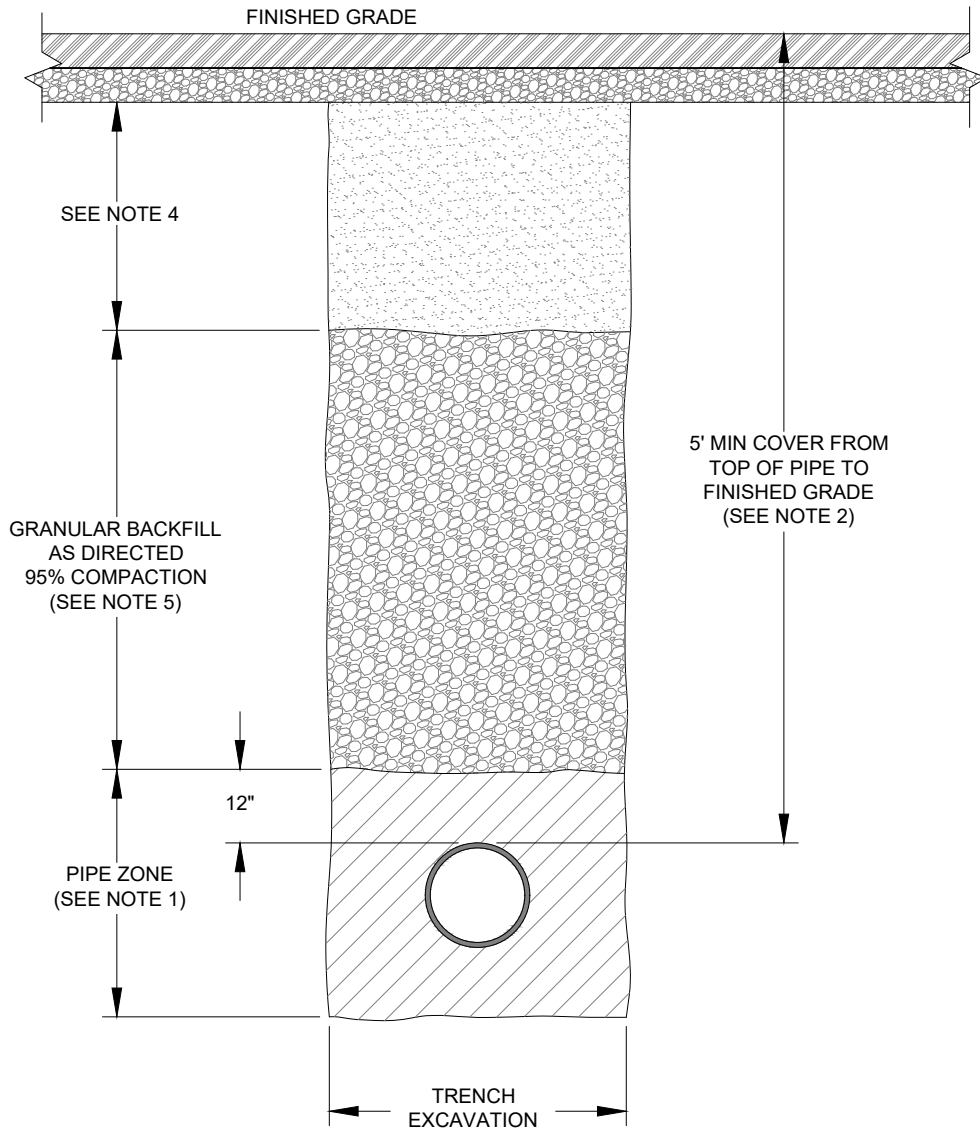

NOTES

1. FOR PIPE ZONE BEDDING, BACKFILL & COMPACTION REQUIREMENTS SEE SEWER DETAILS S-1.1 (RIGID PIPE) & S-1.2 (FLEXIBLE PIPE).
2. MINIMUM COVER FROM TOP OF PIPE TO FINISHED GRADE MAY BE REDUCED TO 3' WHEN APPROVED BY THE CITY, IF C900 PVC (DR18 MIN) PIPE IS USED FOR THE SEWER, AND 5' OF COVER CANNOT BE ACHIEVED USING THE CITY'S STANDARDS FOR DESIGN SLOPE AND ELEVATION DROP THROUGH MANHOLES.
3. CONTROLLED DENSITY FILL (CDF) MAY BE REQUIRED BASED ON LOCAL JURISDICTION STANDARDS.
4. FOR THE TOP ZONE OF THE TRENCH REFER TO APPROVED PROJECT PLANS OR SEE CITY, COUNTY, OR WSDOT STANDARD PLANS AND/OR PERMIT CONDITIONS. FOR NON-PAVED SURFACES, MATCH EXISTING GRAVEL OR SEEDED LAWN.
5. APPROVAL FOR NATIVE ALTERNATE MATERIALS WILL BE GRANTED UPON CONFIRMATION BY TEST OF ITS COMPLIANCE WITH THESE REQUIREMENTS. THE CONTRACTOR SHALL SUBMIT A SAMPLE OF THE NATIVE MATERIAL TO A GEOTECHNICAL ENGINEER FOR LABORATORY TESTING AND ANALYSIS. THE GEOTECHNICAL ENGINEER SHALL PROVIDE A REPORT OF THE SUITABILITY OF THE NATIVE MATERIAL PRIOR TO USE.

N.T.S.

TYPICAL TRENCH SECTION



CITY OF VANCOUVER
DEPARTMENT OF PUBLIC WORKS
SANITARY SYSTEMS PLANNING AND DESIGN

DRAWN BY	APPROVED BY	APPROVAL DATE
BTC	SLH	01 - 2025
REVISION	APPROVED BY	APPROVAL DATE
-	-	-

SEWER
DETAIL NO.
S-1.3

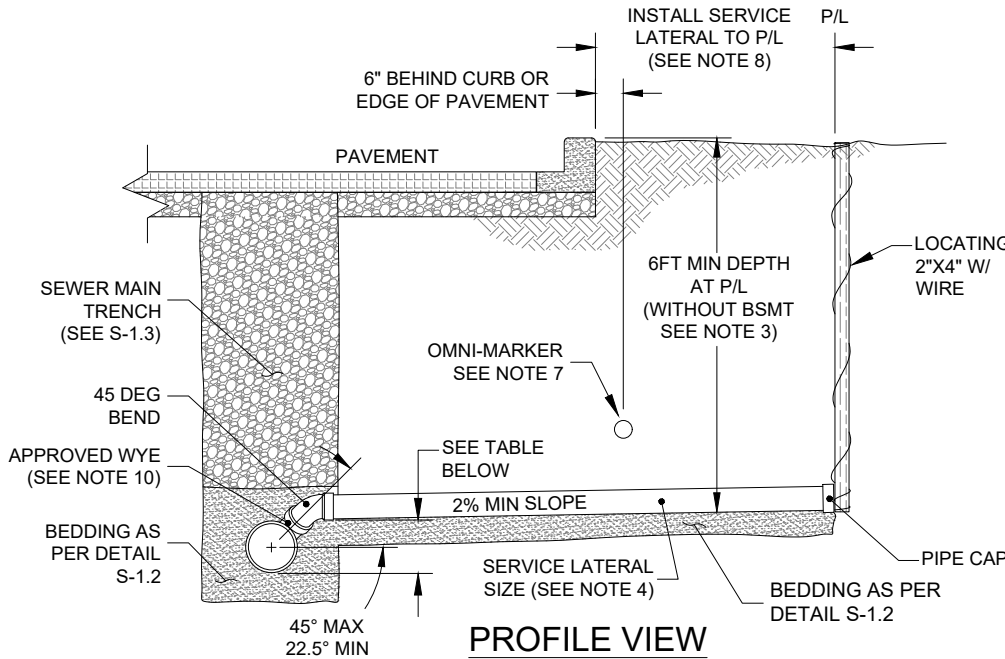

PROFILE VIEW

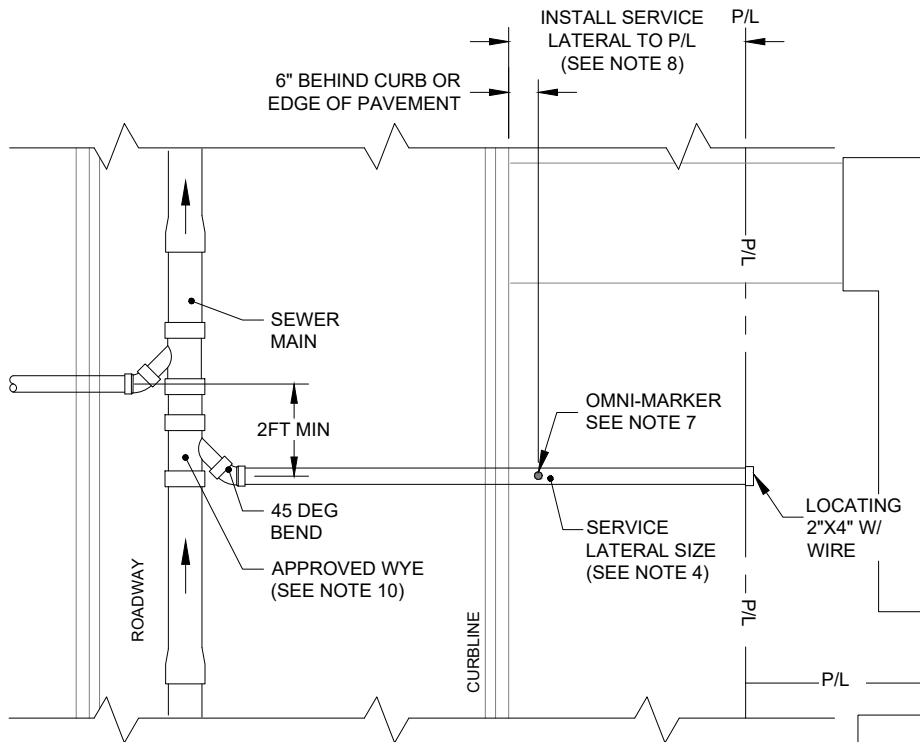

PLAN VIEW

12. SEE SECTION 3-05.07 STORM CROSSINGS

NOTES

1. SERVICE LATERALS SHALL BE INSTALLED PER SECTION 7-08.3 OF THE STANDARD SPECIFICATIONS AND CITY AMENDMENTS.
2. SERVICE LATERALS SHALL BE MARKED AND CAPPED PER SECTIONS 7-08.3(2)F & 7-18.3(5) OF THE STANDARD SPECIFICATIONS AND CITY AMENDMENTS.
3. PROPERTIES WITH BASEMENTS SHALL HAVE THE SERVICE LATERAL EXTENDED AT MAXIMUM DEPTH TO THE PROPERTY LINE.
4. ALL SERVICE LATERALS SHALL BE A MINIMUM OF 6-INCHES IN DIAMETER, LOTS ZONED SINGLE FAMILY RESIDENTIAL CAN USE 4-INCH DIAMETER. ALL LATERALS OVER 6-INCHES REQUIRE A MANHOLE AT THE CONNECTION.
5. SERVICE LATERALS CONNECTING TO EXISTING DUCTILE IRON OR C-900 MAINS SHALL BE THE SAME MATERIAL AS THE MAIN.
6. TRANSITIONS BETWEEN DISSIMILAR PIPE MATERIALS OR SIZES SHALL BE MADE WITH APPROVED ADAPTORS (FERNCO, MAX-ADAPTER OR EQUAL).
7. INSTALL 3M #1404XR, OMNIMARKER OR APPROVED EQUAL SEWER UTILITY MARKER DIRECTLY OVER SERVICE LATERAL PER MANUFACTURERS INSTRUCTIONS (MAXIMUM DEPTH = 5 FT).
8. IN NEW SUBDIVISIONS AND OTHER CONSTRUCTION INVOLVING NEW ROADS, INSTALL LATERALS UP TO PROPERTY LINE FOR SEWERS IN STREET RIGHT-OF-WAY.
9. LATERALS WITH 3 FT TO 5 FT OF COVER SHALL USE C900 PVC (DR18 MIN).
10. WYES SHALL BE USED FOR ALL NEW LATERAL-MAIN CONNECTIONS. NO CROSSES OR DOUBLE WYES ALLOWED. TEES SHALL REQUIRE APPROVAL FROM CITY SEWER ENGINEERING.
11. A SLOPE OF ONE-PERCENT (1%) MAY BE USED FOR 6-INCH LATERALS ONLY. APPROVAL FROM CITY SEWER ENGINEERING IS REQUIRED.

	MIN. CLEARANCE (FROM MAIN IE TO LATERAL IE @ CONNECTION)	
SEWER MAIN DIAMETER	22.5° MIN VERT. OFFSET	45° MAX VERT. OFFSET
8" DIA	0.5 FT	1 FT
10" DIA	0.75 FT	1.25 FT
12" DIA	1.0 FT	1.5 FT

N.T.S.



STANDARD SERVICE LATERAL FOR NEW MAINS

CITY OF VANCOUVER
DEPARTMENT OF PUBLIC WORKS
SANITARY SYSTEMS PLANNING AND DESIGN

DRAWN BY	APPROVED BY	APPROVAL DATE
BTC	SLH	01 - 2025
REVISION	APPROVED BY	APPROVAL DATE
-	-	-

SEWER
DETAIL NO.

S-1.4A
SHEET: 1 OF 5

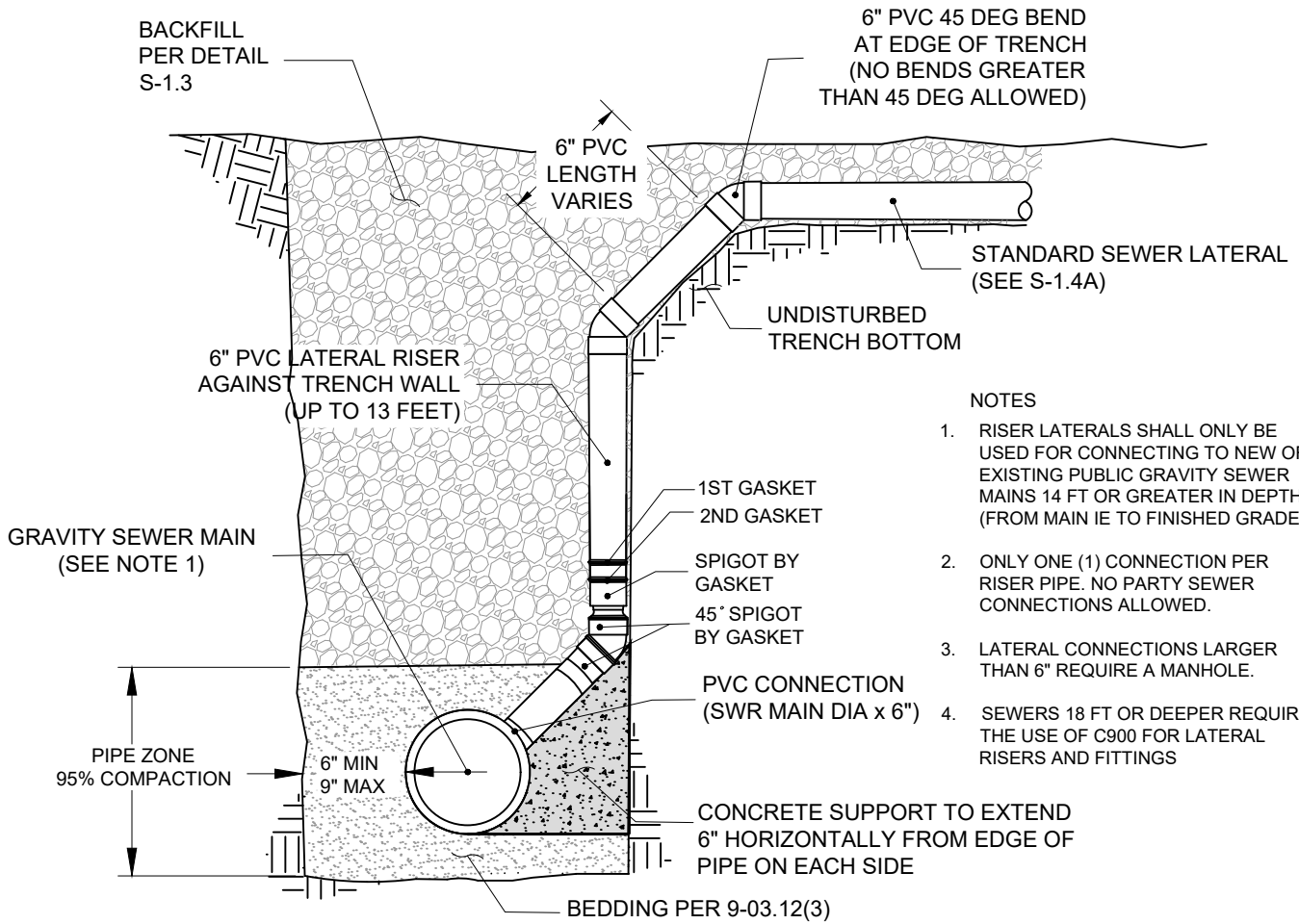

NOTES

1. RISER LATERALS SHALL ONLY BE USED FOR CONNECTING TO NEW OR EXISTING PUBLIC GRAVITY SEWER MAINS 14 FT OR GREATER IN DEPTH (FROM MAIN IE TO FINISHED GRADE).
2. ONLY ONE (1) CONNECTION PER RISER PIPE. NO PARTY SEWER CONNECTIONS ALLOWED.
3. LATERAL CONNECTIONS LARGER THAN 6" REQUIRE A MANHOLE.
4. SEWERS 18 FT OR DEEPER REQUIRE THE USE OF C900 FOR LATERAL RISERS AND FITTINGS

PROFILE VIEW

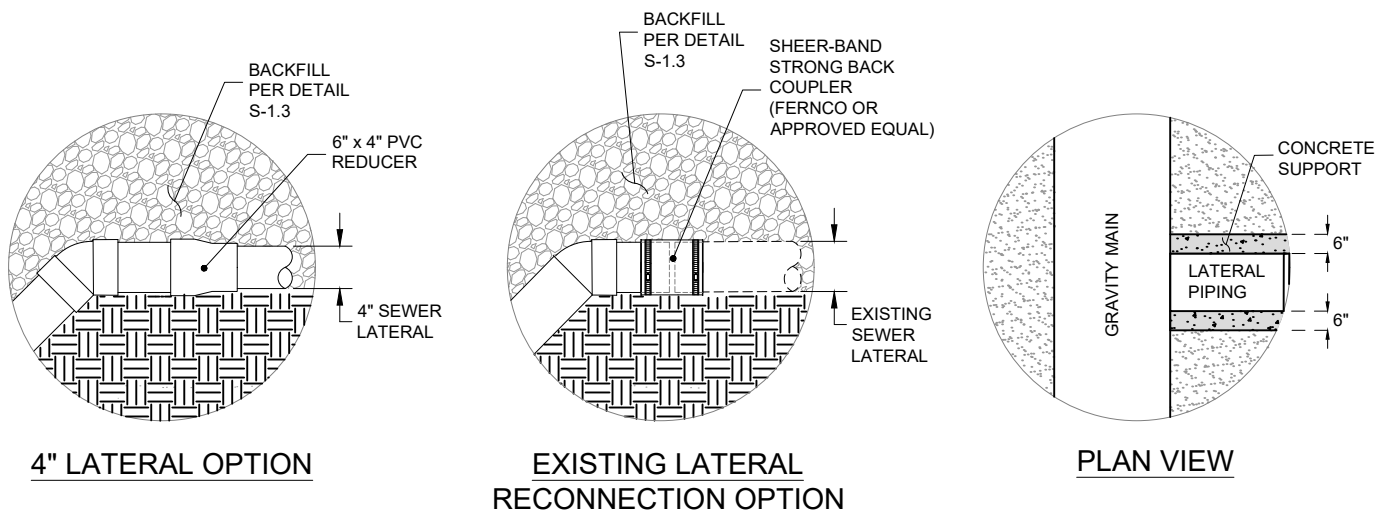

N.T.S.

RISER LATERAL CONNECTION

SEWER
DETAIL NO.



CITY OF VANCOUVER
DEPARTMENT OF PUBLIC WORKS
SANITARY SYSTEMS PLANNING AND DESIGN

DRAWN BY	APPROVED BY	APPROVAL DATE
ANM	SLH	01 - 2025
REVISION	APPROVED BY	APPROVAL DATE
-	-	-

S-1.4B
SHEET: 2 OF 5

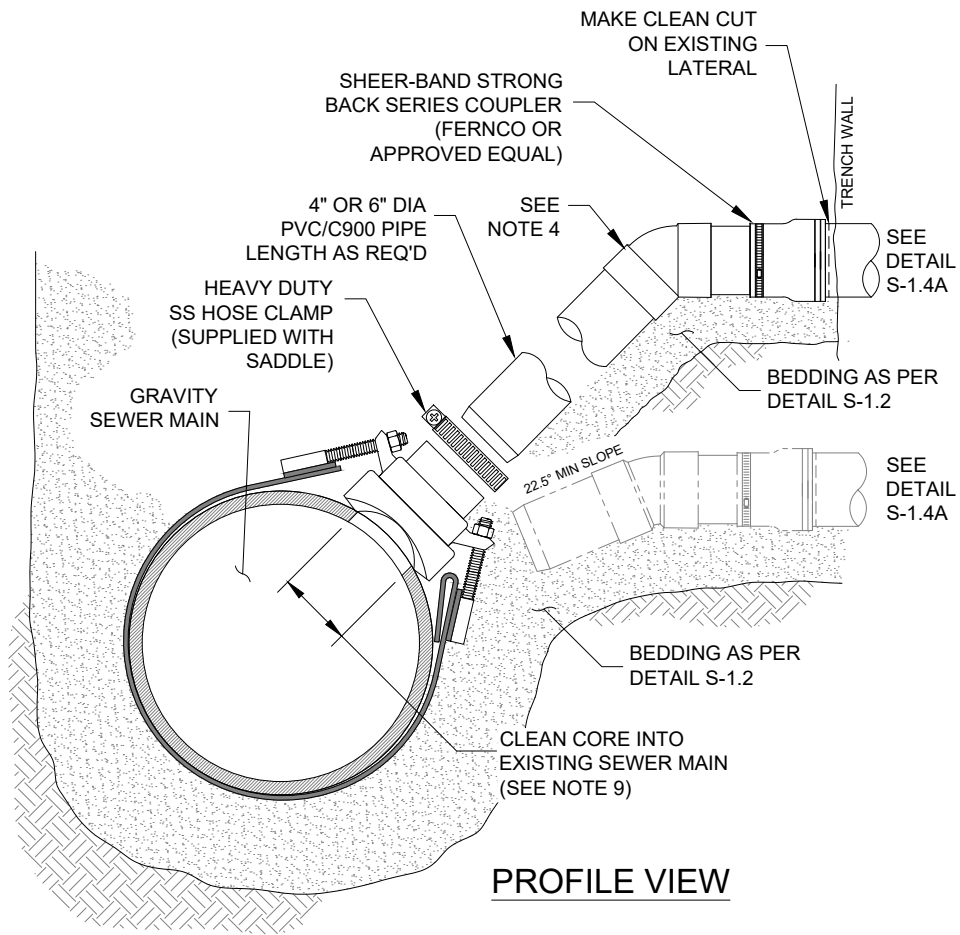

PROFILE VIEW

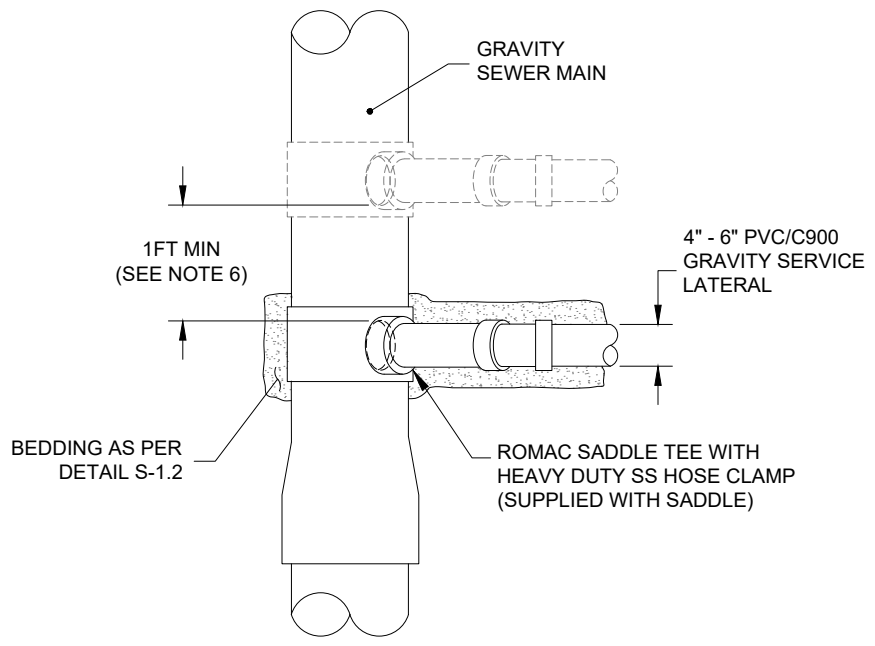

PLAN VIEW

- NOTES:
1. USE ROMAC INDUSTRIES STYLE "CB" SEWER SADDLE FOR CONNECTIONS TO PVC, C900, C.I, D.I, CLAY, AND CONCRETE MAINS (8" THROUGH 15").
 2. FOLLOW MANUFACTURERS INSTALLATION REQUIREMENTS; SADDLE TEE HEX NUTS TO BE TORQUED TO 15-20FT-LBS FOR 6"-12" DIA PIPE.
 3. CORE NEW TAP CONNECTION ON CENTER OF PIPE TO ALLOW FOR BEST FIT.
 4. FITTINGS GREATER THAN 45 DEG ARE NOT ALLOWED
 5. CONTACT CITY OF VANCOUVER PAVEMENT MANAGEMENT FOR HMA RESTORATION REQUIREMENTS.
 6. 1 FT MINIMUM SPACING FROM EDGE TO EDGE OF LATERAL CONNECTION CORES
 7. FOR LATERAL CONNECTIONS TO EXISTING CIPP LINED SEWER MAINS SEE DETAIL S-1.4E
 8. LATERAL CONNECTIONS LARGER THAN 6" REQUIRE A MANHOLE
 9. PRIOR TO BACKFILLING, CONTRACTOR SHALL GET SADDLE TEE CONNECTION INSPECTED AND APPROVED BY CITY.

N.T.S.



SADDLE TAPPING TEE CONNECTION		
CITY OF VANCOUVER DEPARTMENT OF PUBLIC WORKS SANITARY SYSTEMS PLANNING AND DESIGN		
DRAWN BY	APPROVED BY	APPROVAL DATE
BTC	SLH	01 - 2025
REVISION	APPROVED BY	APPROVAL DATE
-	-	-

SEWER
DETAIL NO.
S-1.4C
SHEET: 3 OF 5

SHORT-SIDE LATERAL CONNECTION

LONG-SIDE LATERAL CONNECTION

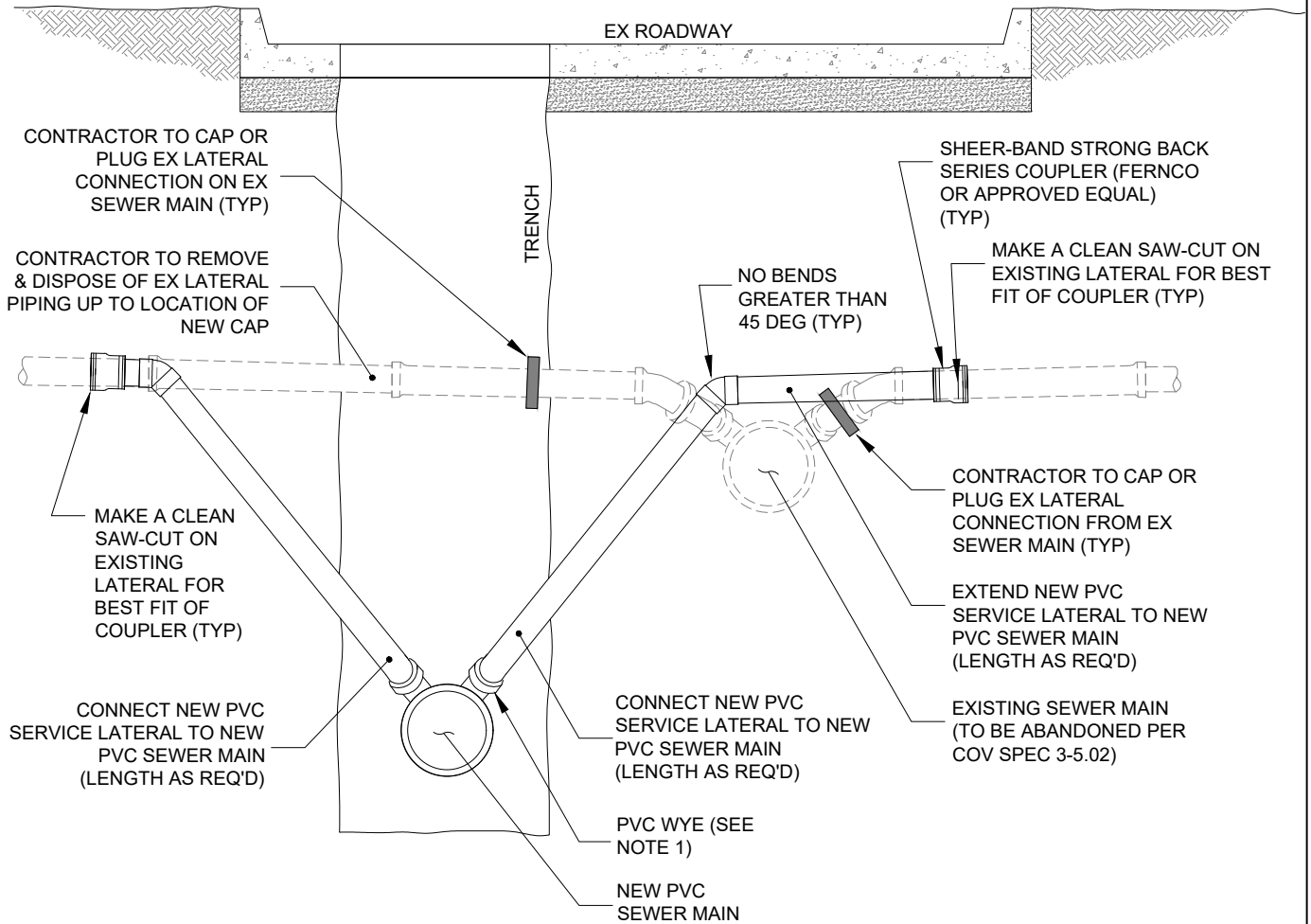

NOTES:

1. CONTRACTOR SHALL USE WYES PER COV DETAIL S-1.4A, CONTRACTOR MAY USE ROMAC CONNECTIONS PER COV DETAIL S-1.4C IF APPROVED BY CITY INSPECTOR.
2. CONTRACTOR RESPONSIBLE FOR LOCATING EXISTING SEWER LATERALS BEFORE RE-CONNECTION IS MADE.

N.T.S.



EXISTING SERVICE LATERAL TO NEW MAINS

CITY OF VANCOUVER
DEPARTMENT OF PUBLIC WORKS
SANITARY SYSTEMS PLANNING AND DESIGN

DRAWN BY	APPROVED BY	APPROVAL DATE
BTC	SLH	01 - 2025
REVISION	APPROVED BY	APPROVAL DATE
-	-	-

SEWER
DETAIL NO.
S-1.4D
SHEET: 4 OF 5

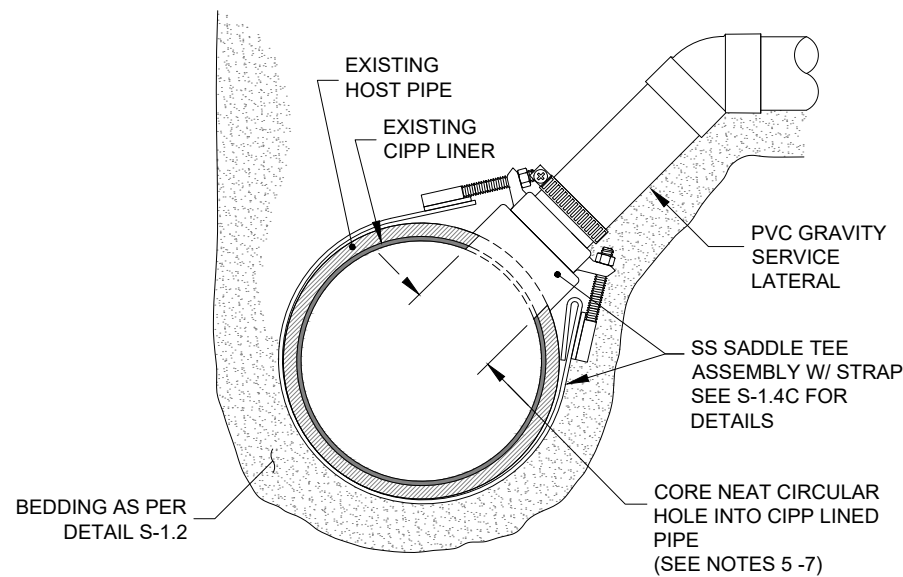

PROFILE VIEW

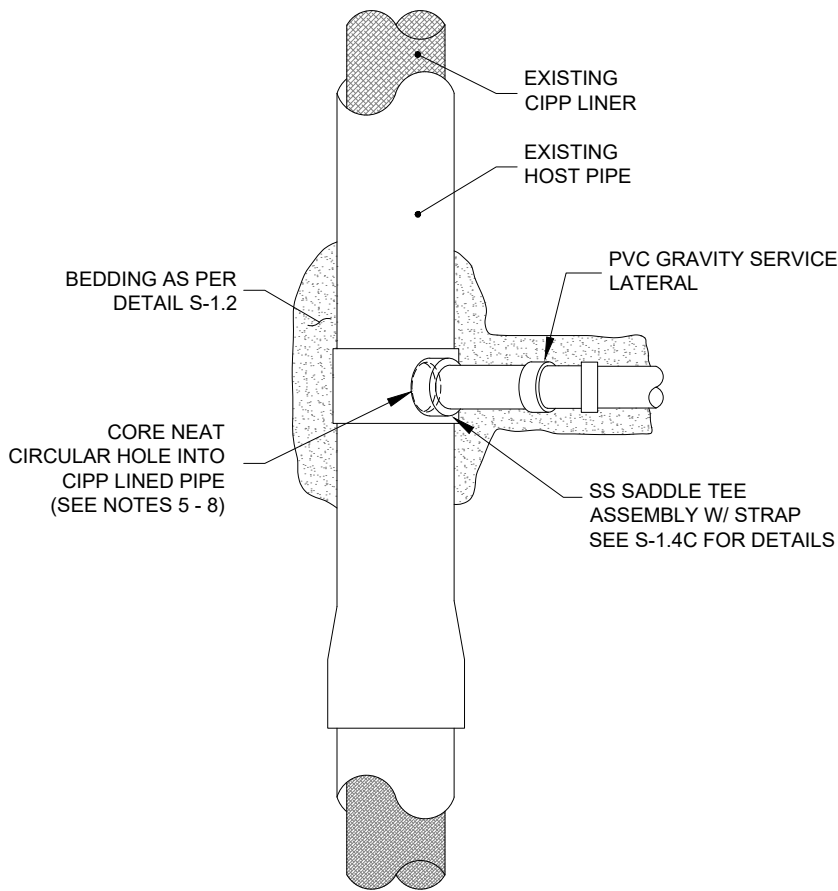

PLAN VIEW

NOTES

1. SERVICE LATERALS SHALL BE INSTALLED PER SECTION 7-08.3 OF THE STANDARD SPECIFICATIONS (LATEST EDITION) AND COV GEN. REQUIREMENTS AND AMENDMENTS.
2. ALL SERVICE LATERALS SHALL BE A MINIMUM OF 6-INCHES IN DIAMETER, LOTS ZONED SINGLE FAMILY RESIDENTIAL BY THE COMPREHENSIVE PLAN CAN USE 4-INCH DIAMETER.
3. SEE S-1.4C FOR APPROVED COMMERCIAL TAP DETAIL.
4. AFTER CORING INTO EXISTING MAIN AND PRIOR TO LATERAL INSTALLATION THE CONTRACTOR SHALL VERIFY WITH THE CITY INSPECTOR THAT THE CIPP LINER HAS NOT BEEN DAMAGED.
5. FOLLOWING INSTALLATION OF LATERAL, CONTRACTOR SHALL TV THE MAIN TO VERIFY THAT THE TAP WAS PROPERLY MADE. A VIDEO OF THE TAP SHALL BE SUBMITTED TO CITY ENGINEERING FOR FINAL APPROVAL.
6. NO PROTRUSIONS, BURRS, OR SHARP EDGES OF ANY KIND ARE ALLOWED AT THE CONNECTION TO THE SEWER MAIN.
7. LATERALS WITH 3 FT TO 5 FT OF COVER SHALL USE C900 PVC (DR 18 MIN).
8. LATERAL CONNECTIONS LARGER THAN 6" REQUIRE A MANHOLE.

N.T.S.



NEW SERVICE LATERAL TO EXISTING CIPP MAIN

CITY OF VANCOUVER
DEPARTMENT OF PUBLIC WORKS
SANITARY SYSTEMS PLANNING AND DESIGN

DRAWN BY	APPROVED BY	APPROVAL DATE
BTC	SLH	01 - 2025
REVISION	APPROVED BY	APPROVAL DATE
-	-	-

SEWER
DETAIL NO.
S-1.4E
SHEET: 5 OF 5

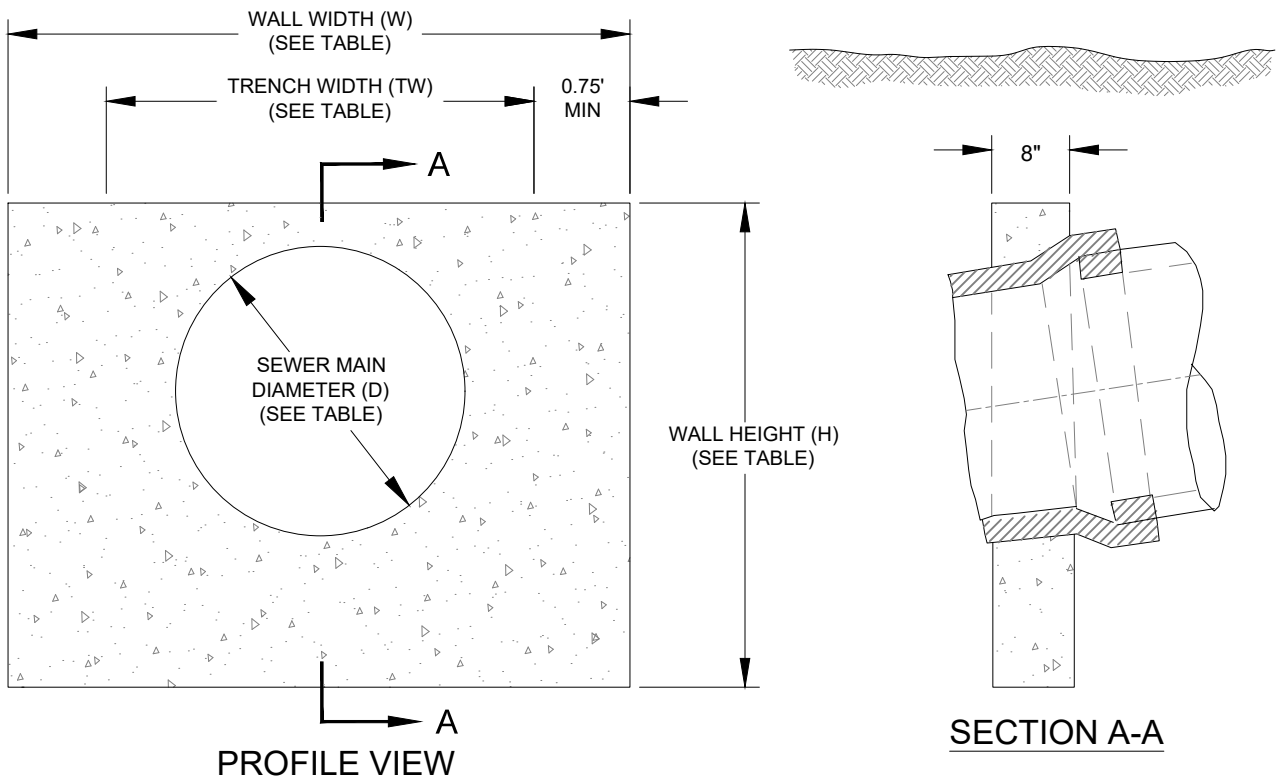

TABLE A		
SLOPE %		MAXIMUM ALLOWABLE SPACING (FT) (MEASURED ON SLOPE)
OVER	TO	
20	35	36
35	50	24
50	100	16

TABLE B				
PIPE SIZE (D)	TRENCH WIDTH MAX (TW)	HEIGHT (H)	WIDTH (W)	VOLUME OF CONCRETE (APPROX.)
8", 10", 12"	2.5'	3.0'	4.0'	0.29 CY
8", 10", 12"	2.5'	4.0'	4.0'	0.37 CY
8", 10", 12"	3.5'	4.0'	5.0'	0.42 CY
8", 10", 12"	4.5'	5.0'	6.0'	0.62 CY

NOTES

1. WALLS SHALL BE APPROVED ON A CASE-BY-CASE BASIS.
2. ALL CONCRETE TO BE CLASS 4000.
3. WALLS WILL BE PLACED WHERE GRADE IS 20% OR OVER; WALLS TO BE AS SHOWN IN TABLE A.
4. ANCHOR WALLS TO BE EQUALLY SPACED WITH MAXIMUM DISTANCE BETWEEN WALLS.
5. PLACE WALL IMMEDIATELY BELOW BELL OF PIPE WHERE POSSIBLE.
6. CONCRETE SHALL BE POURED AGAINST FORMS OR STABLE UNDISTURBED SOIL.

N.T.S.



STANDARD ANCHOR WALL

CITY OF VANCOUVER
DEPARTMENT OF PUBLIC WORKS
SANITARY SYSTEMS PLANNING AND DESIGN

DRAWN BY	APPROVED BY	APPROVAL DATE
BTC	SLH	01 - 2025
REVISION	APPROVED BY	APPROVAL DATE
-	-	-

SEWER
DETAIL NO.
S-1.5

STD 48" PRE-CAST
MANHOLE
(SEE NOTE 13)

FOR MANHOLES IN
ROADWAYS ORIENT
CONE, LID, &
LADDER RINGS OUT
OF WHEEL PATH &
GUTTER

SEWER MAIN
CONNECTION
PER DETAIL S-2.4
(TYP)

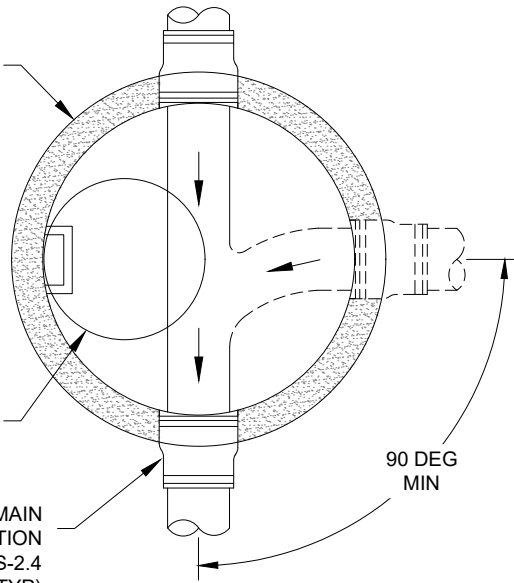

PLAN VIEW

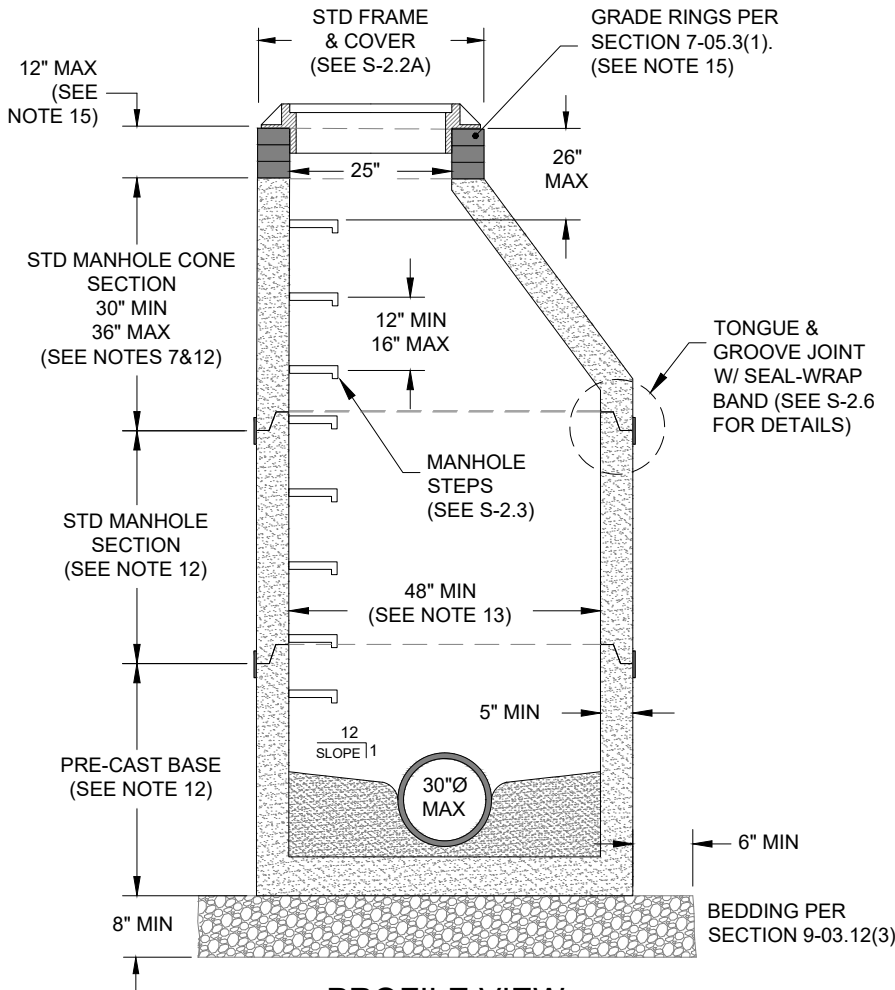

PROFILE VIEW

NOTES

1. ALL PRECAST MANHOLE RINGS AND CONES SHALL CONFORM TO ASTM C-478 WITH CAST IN STEPS (SEE DETAIL S-2.3).
2. IN OVER EXCAVATED AREAS, PROVIDE SUPPORT FOR THE PIPE AS FOLLOWS: PLACE 3/4" MINUS CRUSHED ROCK OVER UNDISTURBED GROUND IN 6" LAYERS AND COMPACT USING HAND TAMPER.
3. BASE CONCRETE SHALL BE 3,000 P.S.I., 2-4 IN. SLUMP. FLOW LINES AND INSIDE SURFACES SHALL BE TROWELED SMOOTH & UNIFORM AT TIME OF POUR. CHANNELS SHALL CONFORM ACCURATELY TO SEWER GRADE. INSTALL BENCHES TO ELEVATION OF SPRINGLINE OF PIPE.
4. PRE-CAST DOGHOUSE MANHOLES MAY BE SUBSTITUTED WITH SPECIFIC APPROVAL OF THE ENGINEER (SEE DETAIL S-2.1C).
5. JOINTS SHALL BE CONSTRUCTED SO AS TO BE WATERTIGHT (SEE DETAIL S-2.6).
6. SEAL ALL MANHOLE JOINTS AND FRAME WITH INFI-SHIELD "SEAL WRAP" EXTERIOR SEAL SYSTEM OR EQUAL.
7. MANHOLES UNDER 6'-0" IN DEPTH FROM RIM TO BENCH SHALL HAVE A TOP SLAB IN LIEU OF CONE (SEE DETAIL S-2.1B).
8. VACUUM TESTING OF MANHOLES WILL BE REQUIRED.
9. LOCKING MANHOLE LIDS ARE REQUIRED IN UNIMPROVED AREAS OR AT THE DISCRETION OF THE CITY INSPECTOR (SEE DETAIL S-2.2B).
10. SEE DETAIL S-5.5 FOR PRESSURE SEWER DISCHARGES INTO MANHOLES.
11. GROUT SHALL BE ALL-CRETE 20 OR CITY-APPROVED EQUAL.
12. PRECAST CONCRETE MANHOLES, INCLUDING GRADE RINGS, ARE TO BE INFUSED WITH ANTI-MICROBIAL INDUCED CORROSION ADDITIVE (CON MICSHIELD, CON-BLOCK, OR APPROVED EQUAL) AT THE TIME OF PRODUCTION. A COLOR ADDITIVE OTHER THAN GREY IS REQUIRED TO PROVIDE VISUAL IDENTIFICATION OF TREATED MANHOLES. SEE SECTION 3-3.03 OF THE SEWER STANDARD SPECIFICATIONS.
13. 60" MANHOLES REQUIRED FOR DROP CONNECTIONS (SEE DETAIL S-2.5A).
14. 0.2 FT MINIMUM DROP THROUGH MANHOLES FOR SEWER MAINS, 0.3 FT MINIMUM DROP FOR SERVICE LATERALS; UNLESS OTHERWISE APPROVED.
15. EACH JOINT MUST BE SEALED W/ EXTERNAL SEALANT (MUST BE GROUTED BETWEEN EACH RING). POLYETHYLENE RINGS MUST BE APPROVED BY THE CITY.

N.T.S.



STANDARD PRECAST MANHOLE

CITY OF VANCOUVER
DEPARTMENT OF PUBLIC WORKS
SANITARY SYSTEMS PLANNING AND DESIGN

DRAWN BY	APPROVED BY	APPROVAL DATE
BTC	SLH	01 - 2025
REVISION	APPROVED BY	APPROVAL DATE
-	-	-

SEWER
DETAIL NO.

S-2.1A
SHEET: 1 OF 5

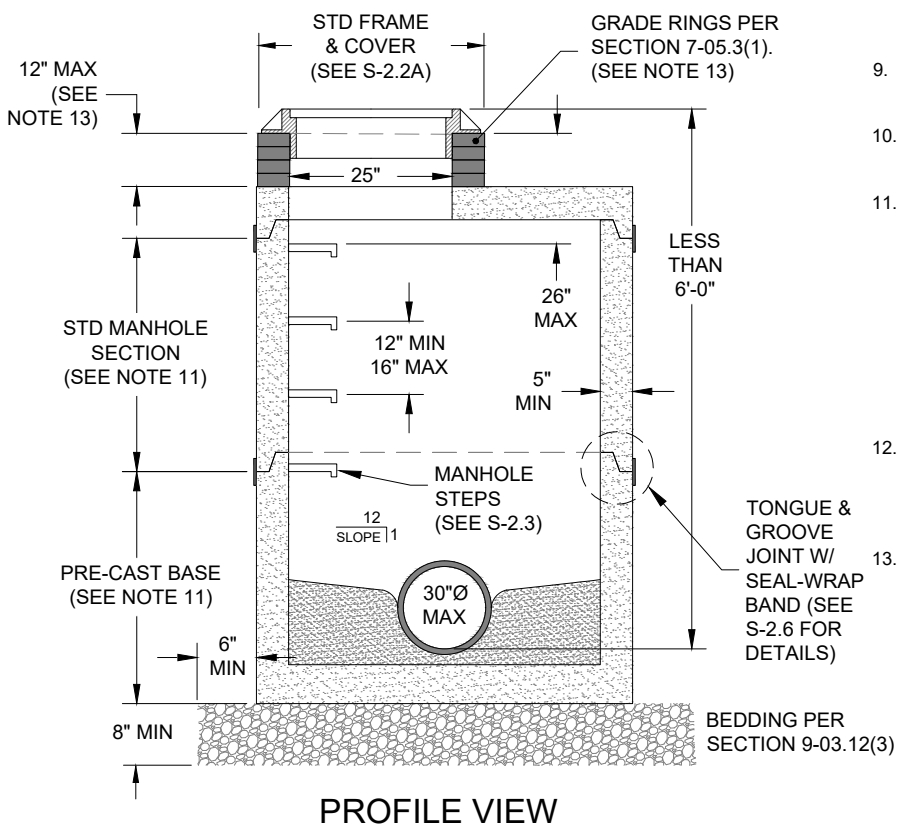
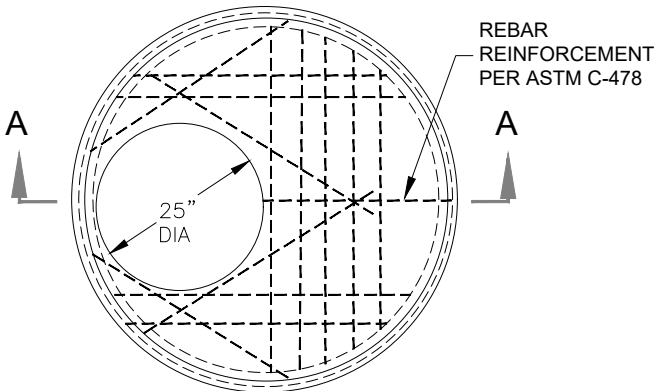
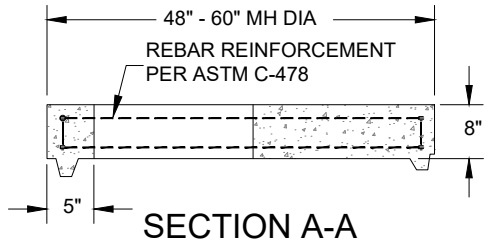

NOTES

1. ALL PRECAST MANHOLE RINGS AND CONES SHALL CONFORM TO ASTM C-478 WITH CAST IN STEPS (SEE DETAIL S-2.3).
2. IN OVER EXCAVATED AREAS, PROVIDE SUPPORT FOR THE PIPE AS FOLLOWS: PLACE 3/4" MINUS CRUSHED ROCK OVER UNDISTURBED GROUND IN 6" LAYERS AND COMPACT USING HAND TAMPER.
3. BASE CONCRETE SHALL BE 3,000 P.S.I. 2-4 IN. SLUMP. FLOW LINES AND INSIDE SURFACES SHALL BE TROWELED SMOOTH & UNIFORM AT TIME OF POUR. MANHOLE BASE MAY BE MONOLITHICALLY CAST TO 8" ABOVE BARREL OF MAIN SEWER. CHANNELS SHALL CONFORM ACCURATELY TO SEWER GRADE. INSTALL BENCHES TO ELEVATION OF SPRINGLINE OF PIPE.
4. PRE-CAST DOGHOUSE MANHOLES MAY BE SUBSTITUTED WITH SPECIFIC APPROVAL OF THE ENGINEER (SEE DETAIL S-2.1C).
5. JOINTS SHALL BE CONSTRUCTED SO AS TO BE WATERTIGHT (SEE DETAIL S-2.6).
6. SEAL ALL MANHOLE JOINTS AND FRAME WITH INFI-SHIELD "SEAL WRAP" EXTERIOR SEAL SYSTEM OR EQUAL.
7. VACUUM TESTING OF MANHOLES WILL BE REQUIRED.
8. LOCKING MANHOLE LIDS ARE REQUIRED IN UNIMPROVED AREAS OR AT THE DISCRETION OF THE CITY INSPECTOR (SEE DETAIL S-2.2B).
9. SEE DETAIL S-5.5 FOR PRESSURE SEWER DISCHARGES INTO MANHOLES.
10. GROUT SHALL BE ALL-CRETE 20 OR CITY-APPROVED EQUAL.
11. PRECAST CONCRETE MANHOLES, INCLUDING GRADE RINGS, ARE TO BE INFUSED WITH ANTI-MICROBIAL INDUCED CORROSION ADDITIVE (CON MICSHIELD, CON-BLOCK, OR APPROVED EQUAL) AT THE TIME OF PRODUCTION. A COLOR ADDITIVE OTHER THAN GREY IS REQUIRED TO PROVIDE VISUAL IDENTIFICATION OF TREATED MANHOLES. SEE SECTION 3-3.03 OF THE SEWER STANDARD SPECIFICATIONS.
12. 0.2 FT MINIMUM DROP THROUGH MANHOLES FOR SEWER MAINS, 0.3 FT MINIMUM DROP FOR SERVICE LATERALS; UNLESS OTHERWISE APPROVED.
13. ADJUST W/ GRADE RINGS PER SECTION 7-05.3(1). EACH JOINT MUST BE SEALED W/ EXTERNAL SEALANT (MUST BE GROUTED BETWEEN EACH RING) POLYETHYLENE RINGS MUST BE APPROVED BY THE CITY

N.T.S.



TOP SLAB MANHOLE		
CITY OF VANCOUVER DEPARTMENT OF PUBLIC WORKS SANITARY SYSTEMS PLANNING AND DESIGN		
DRAWN BY	APPROVED BY	APPROVAL DATE
BTC	SLH	01 - 2025
REVISION	APPROVED BY	APPROVAL DATE
-	-	-

SEWER
DETAIL NO.
S-2.1B
SHEET: 2 OF 5

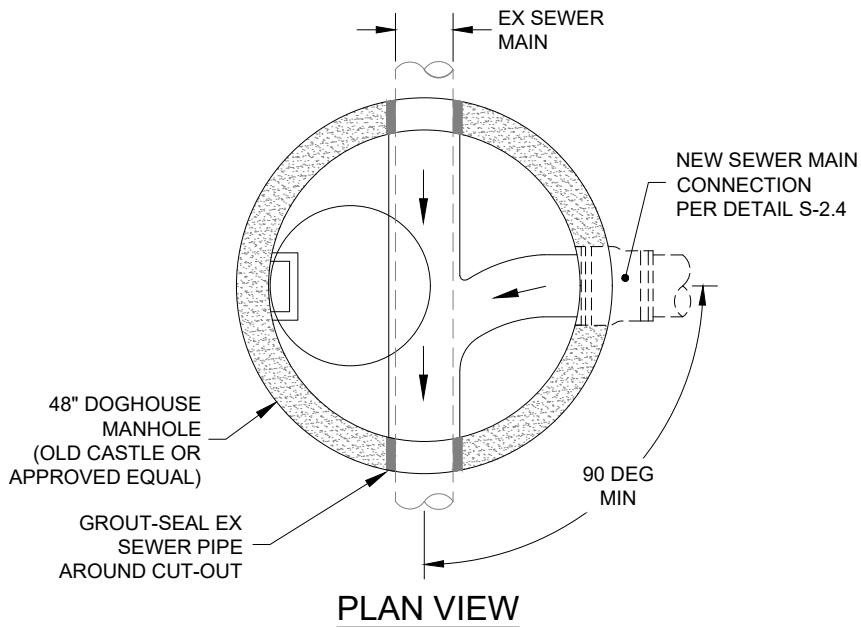

PLAN VIEW

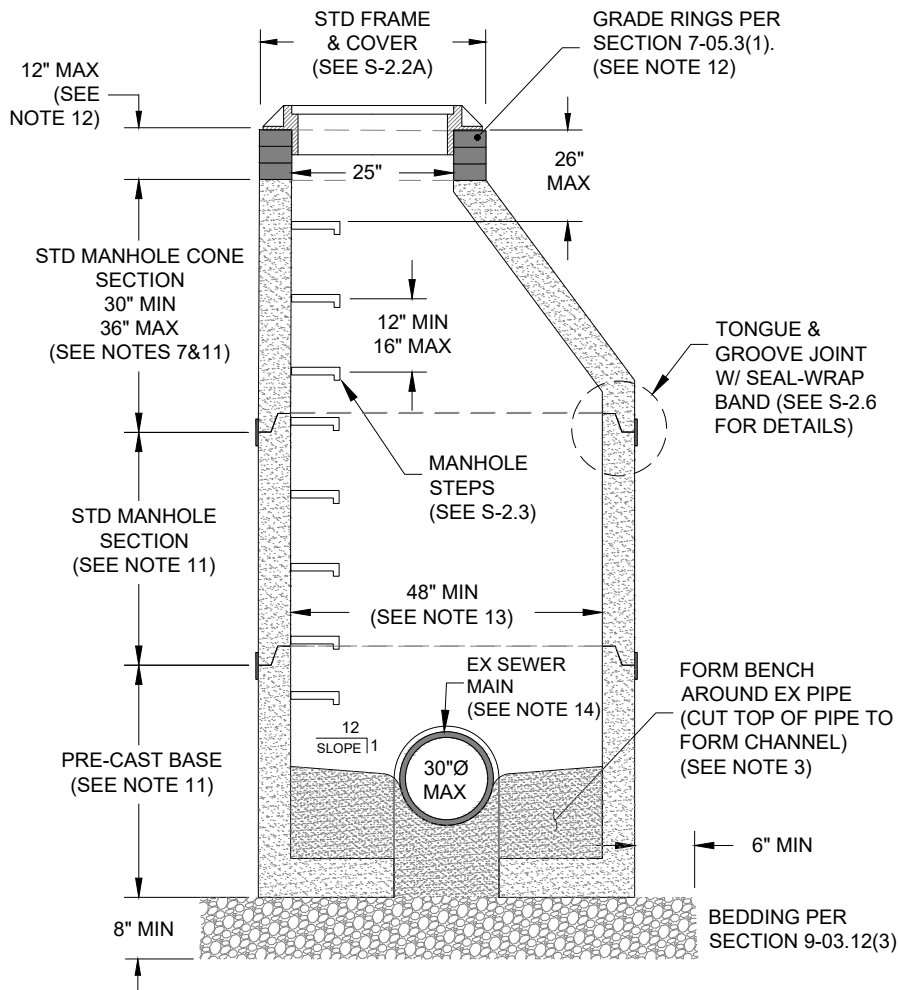

PROFILE VIEW

NOTES

1. ALL PRECAST MANHOLE RINGS AND CONES SHALL CONFORM TO ASTM C-478 WITH CAST IN STEPS (SEE DETAIL S-2.3).
2. IN OVER EXCAVATED AREAS, PROVIDE SUPPORT FOR THE PIPE AS FOLLOWS: PLACE 3/4" MINUS CRUSHED ROCK OVER UNDISTURBED GROUND IN 6" LAYERS AND COMPACT USING HAND TAMPER.
3. BASE CONCRETE SHALL BE 3,000 P.S.I., 2-4 IN. SLUMP. FLOW LINES AND INSIDE SURFACES SHALL BE TROWELED SMOOTH & UNIFORM AT TIME OF POUR. CHANNELS SHALL CONFORM ACCURATELY TO SEWER GRADE. INSTALL BENCHES TO ELEVATION OF SPRINGLINE OF PIPE.
4. JOINTS SHALL BE CONSTRUCTED SO AS TO BE WATERTIGHT (SEE DETAIL S-2.6).
5. SEAL ALL MANHOLE JOINTS AND FRAME WITH INFI-SHIELD "SEAL WRAP" EXTERIOR SEAL SYSTEM OR EQUAL.
6. MANHOLES UNDER 6'-0" IN DEPTH FROM RIM TO BENCH SHALL HAVE A TOP SLAB IN LIEU OF CONE (SEE DETAIL S-2.1B).
7. VACUUM TESTING OF MANHOLES WILL BE REQUIRED.
8. LOCKING MANHOLE LIDS ARE REQUIRED IN UNIMPROVED AREAS OR AT THE DISCRETION OF THE CITY INSPECTOR (SEE DETAIL S-2.2B).
9. SEE DETAIL S-5.5 FOR PRESSURE SEWER DISCHARGES INTO MANHOLES.
10. GROUT SHALL BE ALL-CRETE 20 OR CITY-APPROVED EQUAL.
11. PRECAST CONCRETE MANHOLES, INCLUDING GRADE RINGS, ARE TO BE INFUSED WITH ANTI-MICROBIAL INDUCED CORROSION ADDITIVE (CON MICSHIELD, CON-BLOCK, OR APPROVED EQUAL) AT THE TIME OF PRODUCTION. A COLOR ADDITIVE OTHER THAN GREY IS REQUIRED TO PROVIDE VISUAL IDENTIFICATION OF TREATED MANHOLES. SEE SECTION 3-3.10 OF THE SEWER STANDARD SPECIFICATIONS.
12. ADJUST W/ GRADE RINGS PER SECTION 7-05.3(1). EACH JOINT MUST BE SEALED W/ EXTERNAL SEALANT (MUST BE GROUTED BETWEEN EACH RING) POLYETHYLENE RINGS MUST BE APPROVED BY THE CITY.
13. 60" MANHOLES REQUIRED FOR DROP CONNECTIONS (SEE DETAIL S-2.5A).
14. DOGHOUSE MANHOLES SHALL NOT BE USED OVER EXISTING PVC SEWER MAINS, SEE S-2.1D FOR DETAILS
15. MANHOLES OVER PIPES GREATER THAN 30" REQUIRE SPECIAL APPROVAL FROM COV

N.T.S.



PRE-CAST DOGHOUSE MANHOLE

CITY OF VANCOUVER
DEPARTMENT OF PUBLIC WORKS
SANITARY SYSTEMS PLANNING AND DESIGN

DRAWN BY	APPROVED BY	APPROVAL DATE
BTC	SLH	01 - 2025
REVISION	APPROVED BY	APPROVAL DATE
-	-	-

SEWER
DETAIL NO.
S-2.1C
SHEET: 3 OF 5

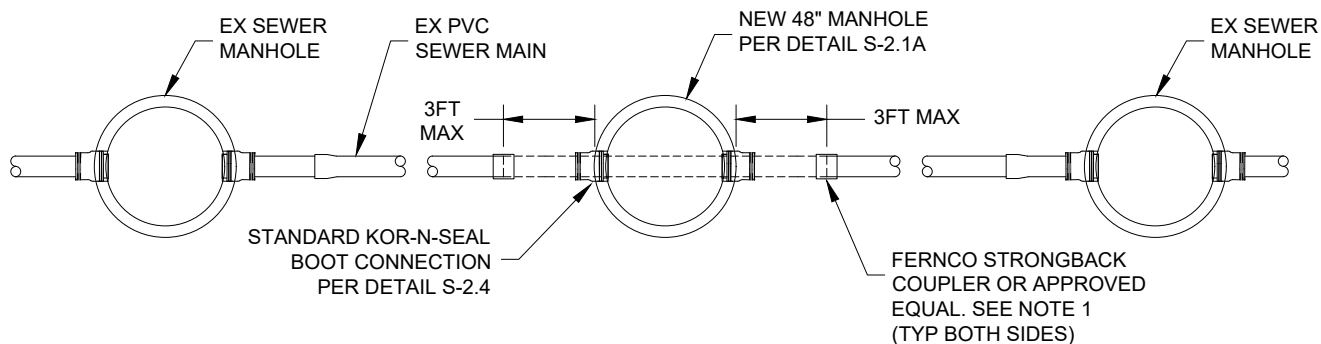

PLAN VIEW

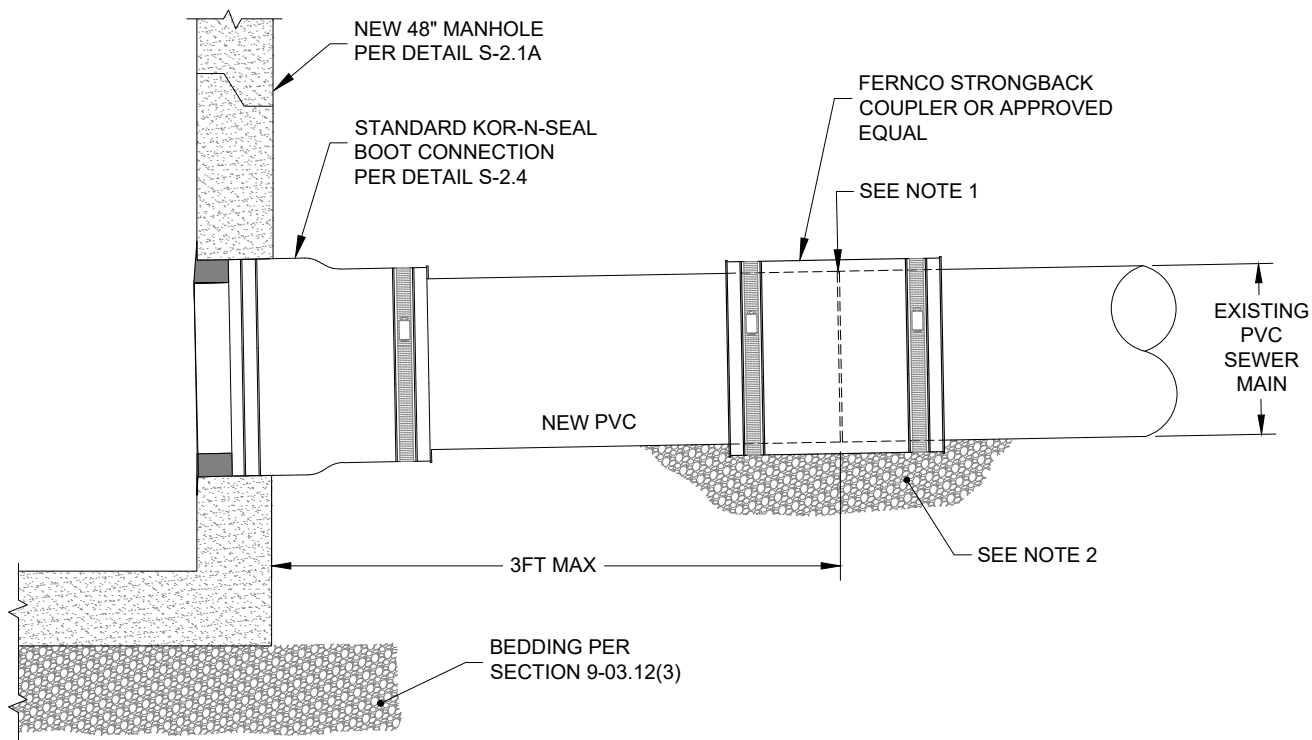

PROFILE VIEW

NOTES:

1. PIPE ENDS SHALL BE CUT TRUE AND FLUSH. THE PIPE SHALL BUTT TOGETHER EVENLY AND TIGHT.
2. CRUSHED SURFACING TOP COURSE SHALL BE PLACED AND COMPACTED AROUND CONNECTION TO ASSURE PIPE STAYS TRUE AND NO SETTLEMENT OCCURS.
3. CCTV INSPECTION AND APPROVAL REQUIRED PRIOR TO FINAL BACKFILL AND COMPACTION
4. BYPASS PLAN REQUIRED PER SECTION 7-17.03(3) OF CITY AMENDMENTS TO THE WSDOT STANDARD SPECIFICATIONS

N.T.S.



NEW MANHOLE CONNECTION TO EX. PVC SEWER MAIN

CITY OF VANCOUVER
DEPARTMENT OF PUBLIC WORKS
SANITARY SYSTEMS PLANNING AND DESIGN

DRAWN BY	APPROVED BY	APPROVAL DATE
BTC	SLH	01 - 2025
REVISION	APPROVED BY	APPROVAL DATE
-	-	-

SEWER
DETAIL NO.
S-2.1D
SHEET: 4 OF 5

NOTES

1. AFTER SAWCUTTING INTO EXISTING SEWER MAIN AND PRIOR TO FINAL MANHOLE INSTALLATION THE CONTRACTOR SHALL VERIFY WITH THE CITY INSPECTOR THAT THE CIPP LINER HAS NOT BEEN DAMAGED.
2. FOLLOWING INSTALLATION OF MANHOLE, CONTRACTOR SHALL TV THE MAIN TO VERIFY THAT THE MANHOLE CONNECTION WAS PROPERLY MADE. A VIDEO OF THE LINER SHALL BE SUBMITTED TO THE CITY FOR FINAL INSPECTION AND APPROVAL.
3. NO PROTRUSIONS, BURRS, OR SHARP EDGES OF ANY KIND ARE ALLOWED AT THE CONNECTION TO THE SEWER MAIN.
4. APPLY 125 MIL THICKNESS EPOXY COATING ON **ALL EXPOSED LINER SURFACES**, INCLUDING THE ENTIRE MANHOLE BENCH, PIPE PENETRATION, AND DOWN TO THE SPRINGLINE OF THE NEW MANHOLE CHANNEL (RAVEN 405 OR APPROVED EQUAL).

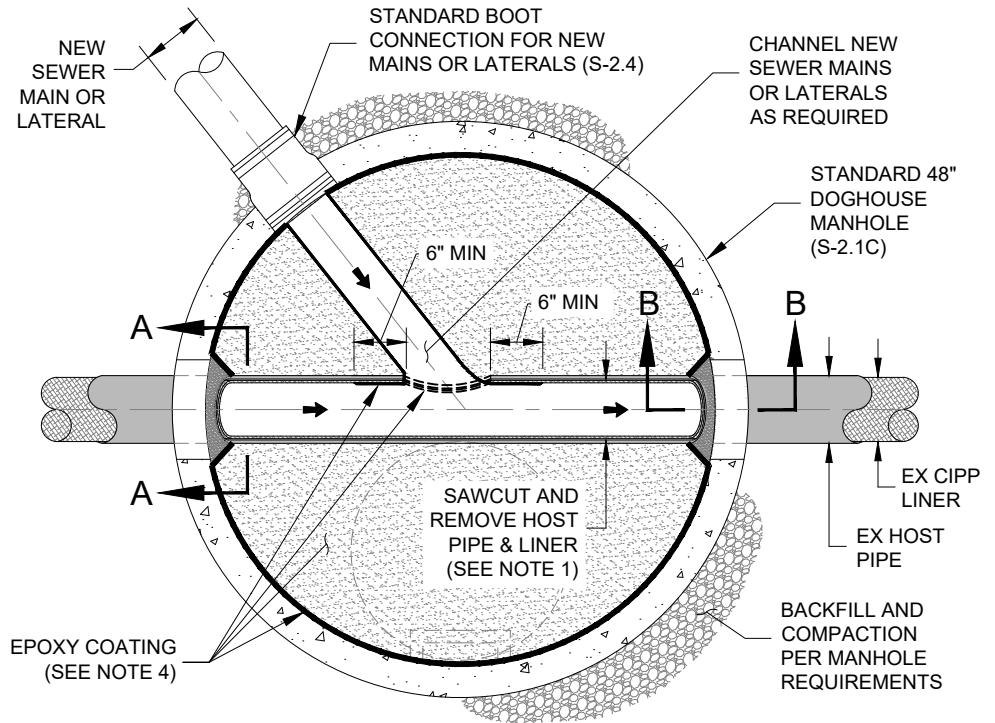

**MANHOLE CONNECTION
PLAN VIEW**

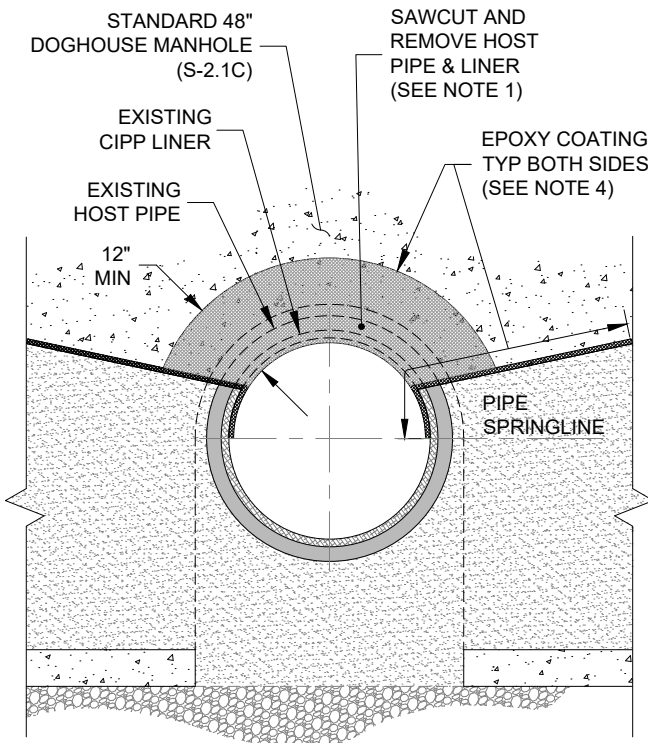

SECTION VIEW A-A

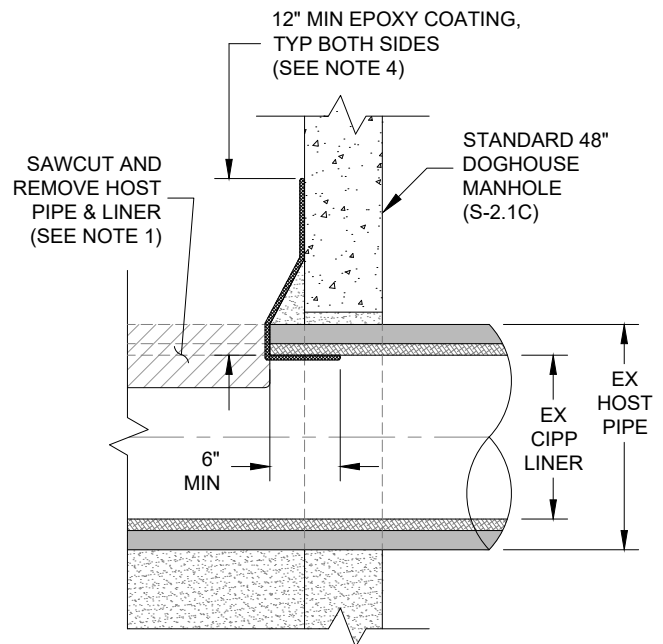

SECTION VIEW B-B

N.T.S.



NEW MANHOLE OVER EX. CIPP LINED SEWER MAIN

CITY OF VANCOUVER
DEPARTMENT OF PUBLIC WORKS
SANITARY SYSTEMS PLANNING AND DESIGN

DRAWN BY	APPROVED BY	APPROVAL DATE
BTC	SLH	01 - 2025
REVISION	APPROVED BY	APPROVAL DATE
-	-	-

SEWER
DETAIL NO.

S-2.1E
SHEET: 5 OF 5

NOTES

- STANDARD MANHOLE LID TO BE USED IN ALL PAVED PUBLIC RIGHT OF WAY AREAS.

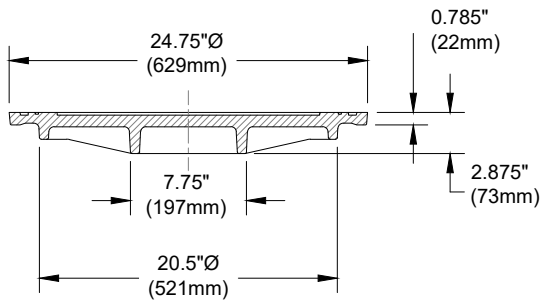

SECTION A-A

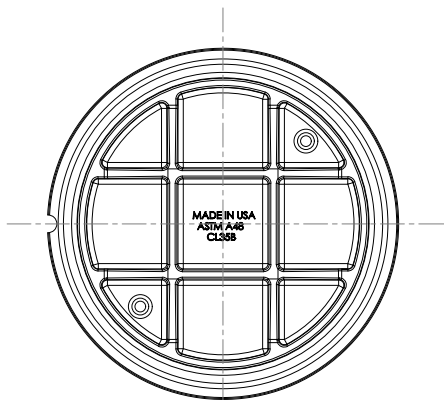

BOTTOM VIEW

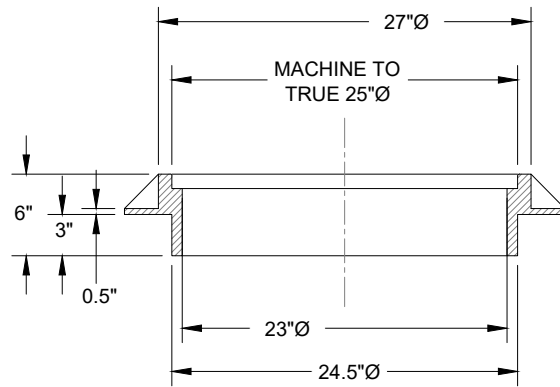

SECTION B-B

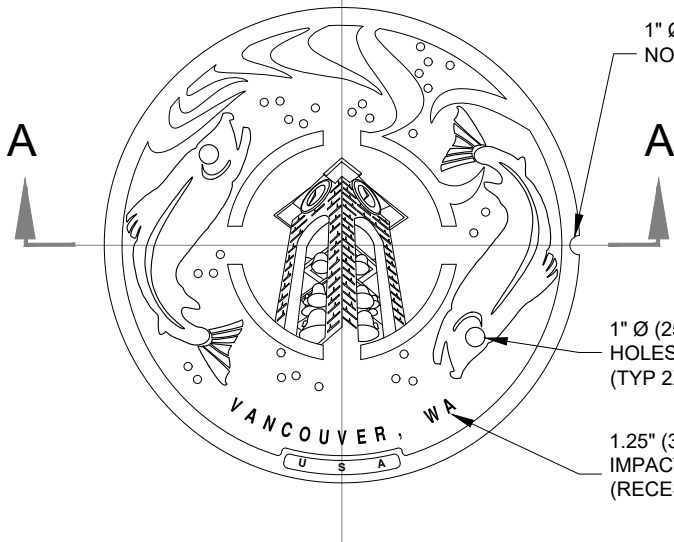

STANDARD SUBURBAN MANHOLE LID
PLAN VIEW

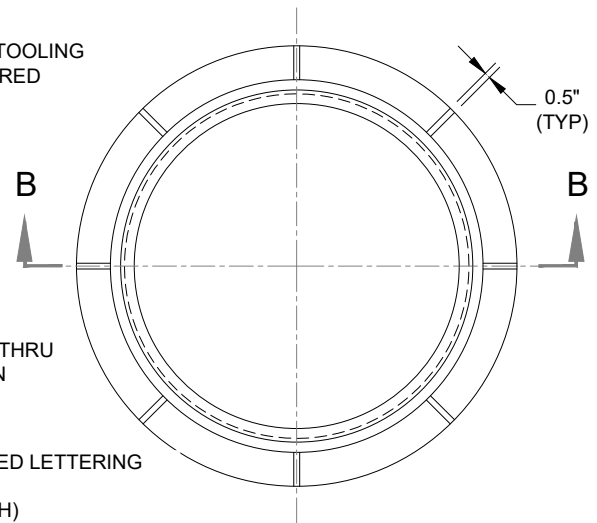

SUBURBAN MANHOLE FRAME
PLAN VIEW

N.T.S.



STANDARD SUBURBAN MANHOLE LID AND FRAME

CITY OF VANCOUVER
DEPARTMENT OF PUBLIC WORKS
SANITARY SYSTEMS PLANNING AND DESIGN

DRAWN BY	APPROVED BY	APPROVAL DATE
BTC	SLH	01 - 2025
REVISION	APPROVED BY	APPROVAL DATE
-	-	-

SEWER
DETAIL NO.

S-2.2A
SHEET: 1 OF 5

NOTES

1. LOCKING MANHOLE LID TO BE USED IN NON PAVED AREAS OR WITHIN REMOTE EASEMENTS.

1/2"-13 NC X 1-1/2" HEX
HEAD SS BOLT
(3 REQ'D)

1-1/4" OD SS FLAT
WASHER 3/32" THICK
(3 REQ'D)

1-1/4" RUBBER
FLAT WASHER
(3 REQ'D)

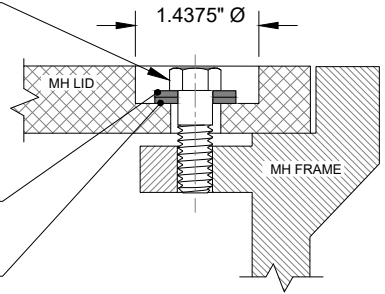

BOLT DOWN DETAIL

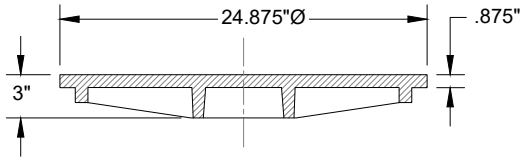

SECTION A-A

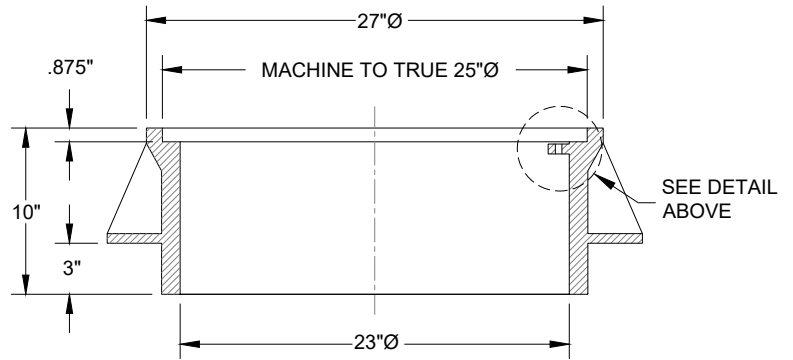

SECTION B-B

TOOLING
NOTCH
REQUIRED

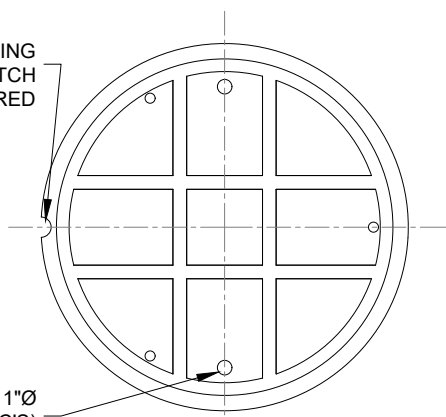

BOTTOM VIEW

SEE BOLT
DOWN DETAIL
(3 PLC'S)

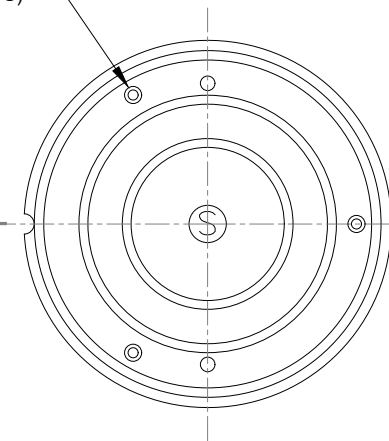

**LOCKING MANHOLE LID
PLAN VIEW**

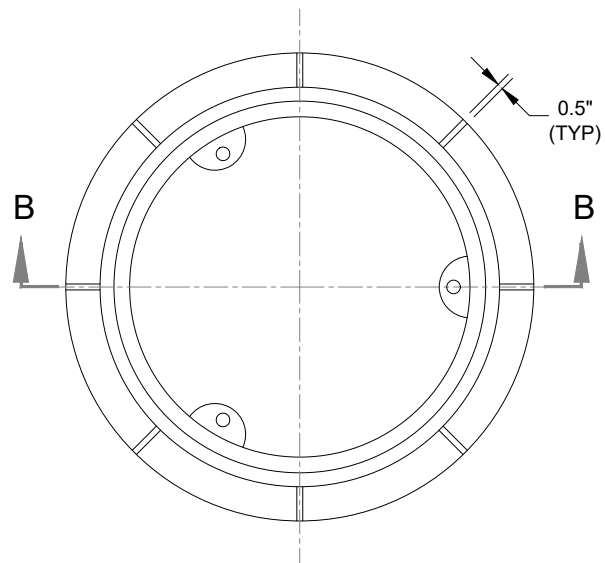

**LOCKING MANHOLE FRAME
PLAN VIEW**

N.T.S.



LOCKING MANHOLE LID AND FRAME

CITY OF VANCOUVER
DEPARTMENT OF PUBLIC WORKS
SANITARY SYSTEMS PLANNING AND DESIGN

DRAWN BY	APPROVED BY	APPROVAL DATE
BTC	SLH	01 - 2025
REVISION	APPROVED BY	APPROVAL DATE
-	-	-

SEWER
DETAIL NO.

S-2.2B
SHEET: 2 OF 5

NOTES

1. PAMREX OR APPROVED EQUAL MANHOLE COVER AND FRAME.
2. COVERS SHALL BE ONE-MAN OPERABLE USING STANDARD TOOLS.
3. FRAMES SHALL BE CIRCULAR AND SHALL INCORPORATE A SEATED GASKET.
4. PAMREX COVERS AND LIDS ARE REQUIRED FOR SEWER MANHOLES INSTALLED WITHIN THE 100-YEAR FLOOD PLAIN OR WHERE STORM WATER MAY ACCUMULATE.
5. SEE S-2.1A FOR STANDARD RISER RING INSTALLATION.

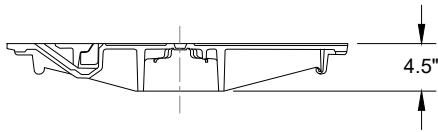

PROFILE VIEW

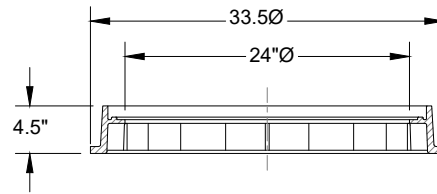

SECTION A-A

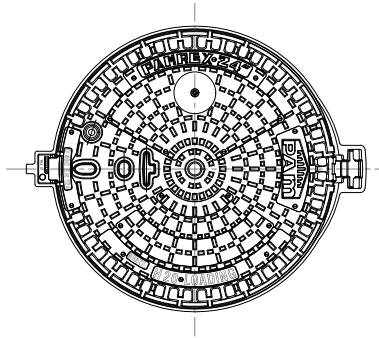

PAMREX MANHOLE LID
PLAN VIEW

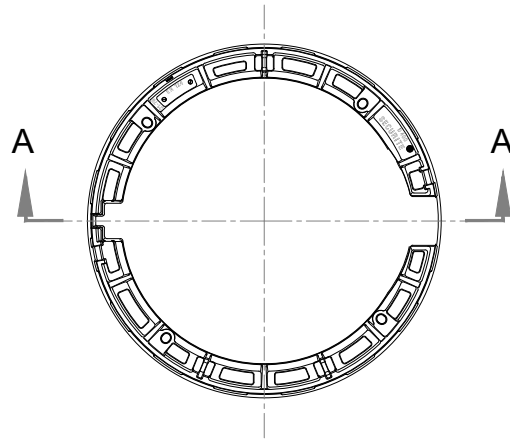

PAMREX MANHOLE FRAME
PLAN VIEW

N.T.S.



PAMREX (WATERTIGHT) LID AND FRAME

CITY OF VANCOUVER
DEPARTMENT OF PUBLIC WORKS
SANITARY SYSTEMS PLANNING AND DESIGN

DRAWN BY	APPROVED BY	APPROVAL DATE
BTC	SLH	01 - 2025
REVISION	APPROVED BY	APPROVAL DATE
-	-	-

SEWER
DETAIL NO.

S-2.2C
SHEET: 3 OF 5

NOTES

1. GMI COMPOSITES OR APPROVED EQUAL COMPOSITE MANHOLE COVER AND FRAME.
2. COVERS SHALL BE ONE-MAN OPERABLE USING STANDARD TOOLS.
3. FRAMES SHALL BE CIRCULAR.
4. GMI COMPOSITE COVERS AND LIDS FOR USE IN LOCATIONS WITH HIGH H2S/ODOR AND UN-IMPROVED AREAS.

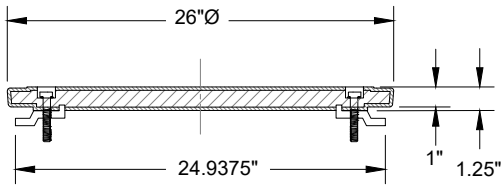

SECTION A-A

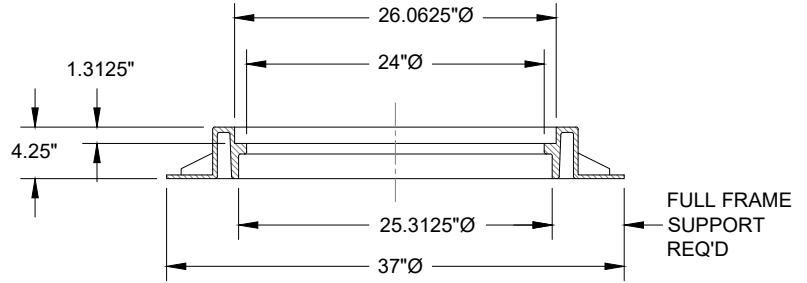

SECTION B-B

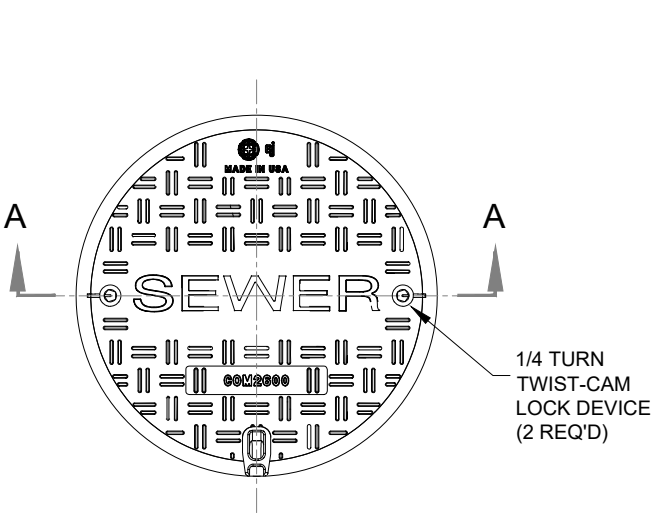

COMPOSITE MANHOLE LID
PLAN VIEW

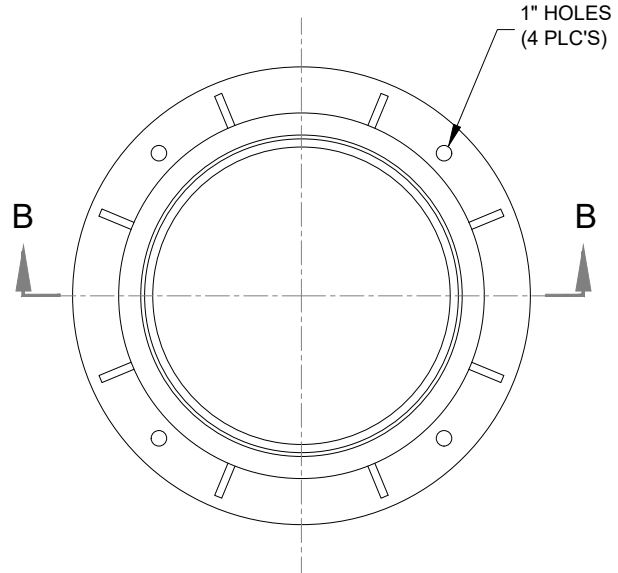

COMPOSITE MANHOLE FRAME
PLAN VIEW

N.T.S.



COMPOSITE LID AND FRAME FOR H2S

CITY OF VANCOUVER
DEPARTMENT OF PUBLIC WORKS
SANITARY SYSTEMS PLANNING AND DESIGN

DRAWN BY	APPROVED BY	APPROVAL DATE
BTC	SLH	01 - 2025
REVISION	APPROVED BY	APPROVAL DATE
-	-	-

SEWER
DETAIL NO.

S-2.2D
SHEET: 4 OF 5

ITEM NO.	PART NUMBER	DESCRIPTION	QTY.
1	23" X 3" MH	RIMRISER ADJUSTABLE 3" (SUBURBAN) MANHOLE	1
2	RR-0001	5/8" SLOT NUT INSERT	4
3	RR-0058-4	5/8" X 4" JACK SCREW / 5/8" HEX HEAD	4

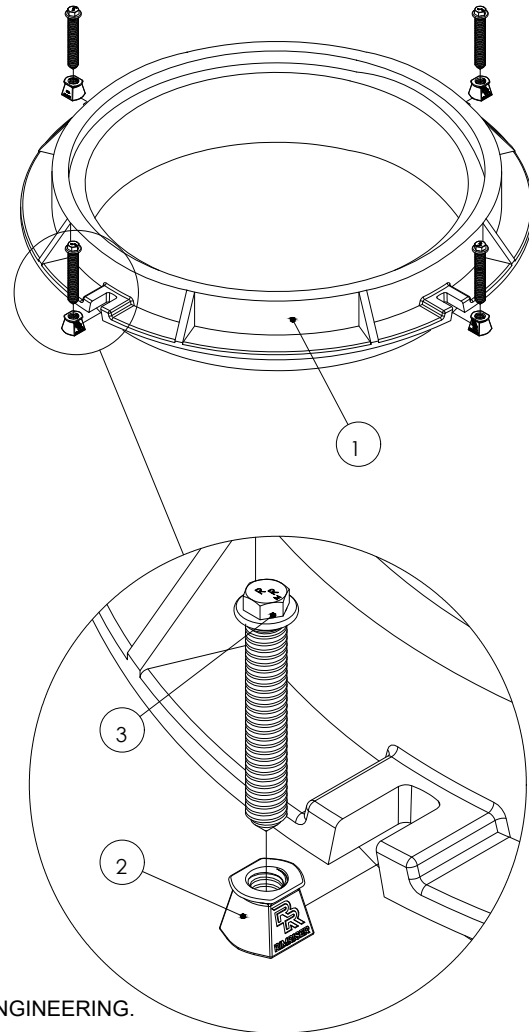
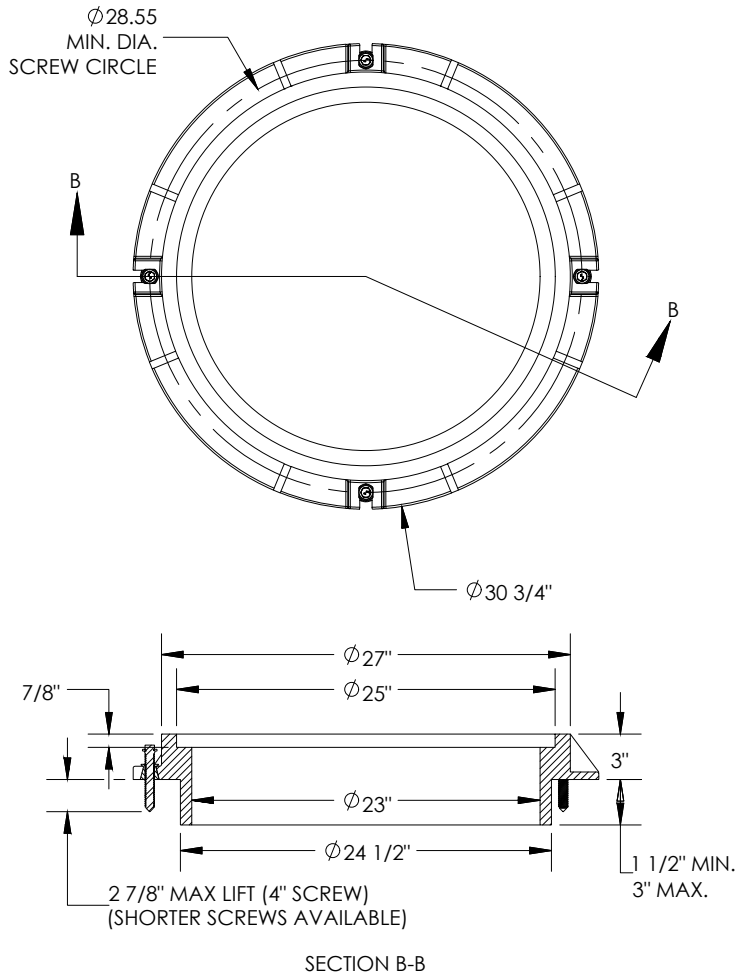

NOTES:

- ADJUSTABLE MANHOLE FRAMES REQUIRE APPROVAL FROM CITY ENGINEERING.
- NO SHIMS REQUIRED. ADJUST SCREWS TO MEET FINISHED GRADE.
- CASTING ASSEMBLY: AASHTO M-306 CERTIFIED; H-20 OR "TRAFFIC-RATED".
- CASTINGS: GRAY IRON CONFORMS TO ASTM A48 CL35B.
- SCREWS: ZINC-PLATED, MILD STEEL CONFORMS TO ASTM A1018.
- NUTS: ZINC ALLOY CONFORMS TO ASTM C41A.
- FILL AND PACK GAP BETWEEN FRAME AND SUPPORTING BASE WITH NON-SHRINK GROUT AND FINISH SMOOTH/FLUSH WITH INTERIOR AND EXTERIOR OF ADJOINING SURFACES.
- USE ONLY GENUINE RIMRISER PARTS.
- SEE STANDARD DETAIL S-2.1A FOR APPROVED MANHOLE LID.

N.T.S.



ADJUSTABLE MANHOLE FRAME (RIM-RISER)

CITY OF VANCOUVER
DEPARTMENT OF PUBLIC WORKS
SANITARY SYSTEMS PLANNING AND DESIGN

DRAWN BY	APPROVED BY	APPROVAL DATE
BTC	SLH	01 - 2025
REVISION	APPROVED BY	APPROVAL DATE
-	-	-

SEWER
DETAIL NO.

S-2.2E
SHEET: 5 OF 5

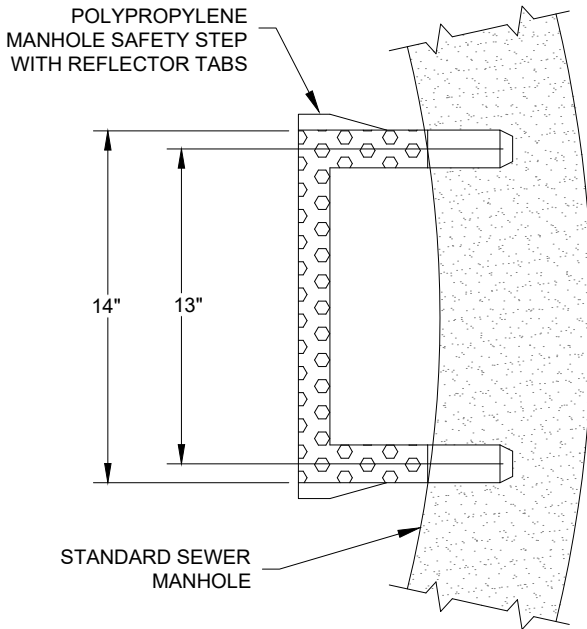

PLAN VIEW

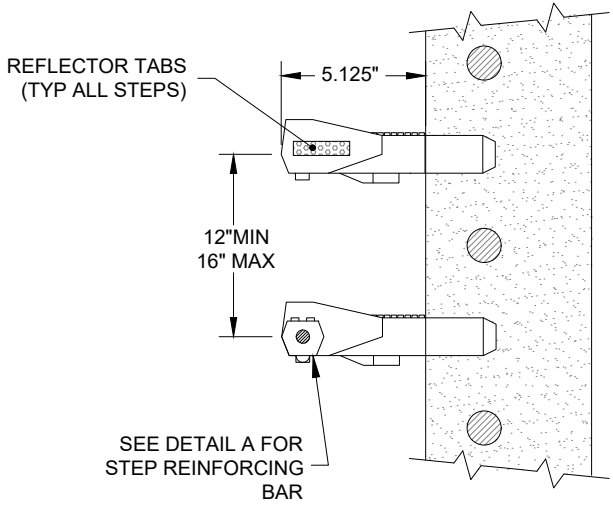

ELEVATION VIEW

NOTES

1. INSTALLATION OF STEPS SHALL MEET ASTM C-478 & AASHTO M-199 SPECIFICATIONS. POLYPROPYLENE ASTM D-4104, THE 1/2" GRADE 60 STEEL REINFORCED BARS SHALL MEET ASTM A-615.
2. INSTALLATION METHOD MUST RESIST 1500LBS HORIZONTAL PULL-OUT FORCE AND 500LB VERTICAL LOAD.
3. LOCATE STEPS OVER BENCH WHENEVER POSSIBLE (NOT OVER MAIN).

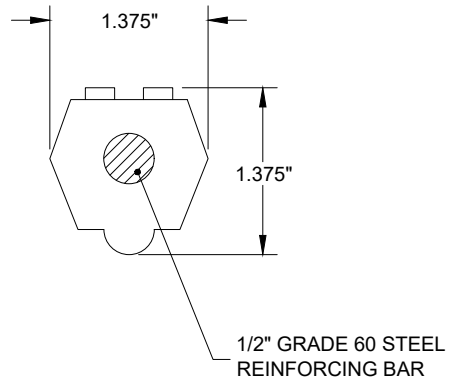

DETAIL A

N.T.S.



STANDARD MANHOLE STEPS		
CITY OF VANCOUVER DEPARTMENT OF PUBLIC WORKS SANITARY SYSTEMS PLANNING AND DESIGN		
DRAWN BY	APPROVED BY	APPROVAL DATE
BTC	SLH	01 - 2025
REVISION	APPROVED BY	APPROVAL DATE
-	-	-

SEWER
DETAIL NO.
S-2.3

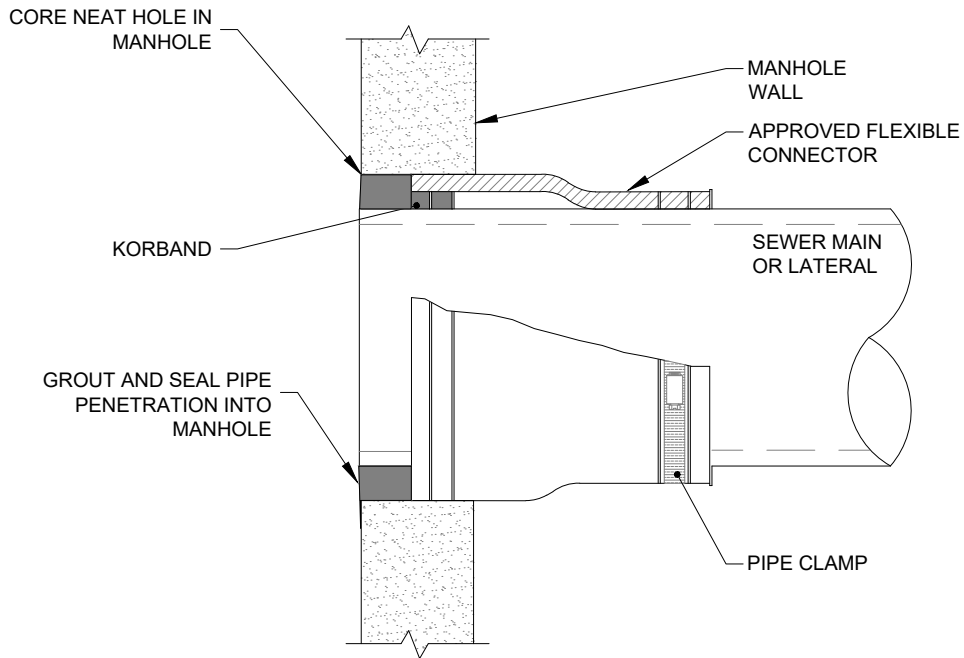

NOTES

1. SEWER MAIN AND LATERALS CONNECTING TO MANHOLES SHALL BE MADE WITH AN APPROVED EXPANSION TYPE RUBBER BOOT; KOR-N-SEAL ® OR SEALTITE ®, (NO FLEX JOINT REQUIRED),
2. FOR ALL PIPES UP TO 18". LARGER PIPES WILL BE HANDLED ON A CASE-BY-CASE BASIS. CORE NEAT HOLE IN MANHOLE AND INSTALL BOOT AS REQUIRED PER MANUFACTURER'S SPECIFICATIONS.
3. STUB-OUTS CONSTRUCTED FOR FUTURE EXTENSIONS ARE TO BE INSTALLED WITH STUB MARKERS PER DETAIL S-3.0.
4. SAND-COLLAR CONNECTIONS ARE NOT ALLOWED WITHOUT CITY ENGINEERING APPROVAL

N.T.S.



STANDARD MANHOLE CONNECTION

CITY OF VANCOUVER
DEPARTMENT OF PUBLIC WORKS
SANITARY SYSTEMS PLANNING AND DESIGN

DRAWN BY	APPROVED BY	APPROVAL DATE
BTC	SLH	01 - 2025
REVISION	APPROVED BY	APPROVAL DATE
-	-	-

SEWER
DETAIL NO.

S-2.4

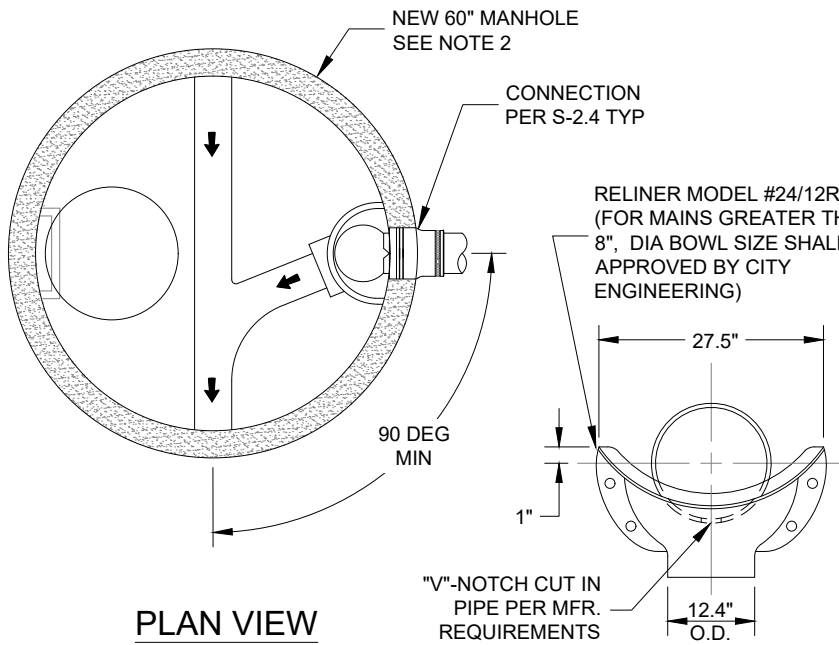

PLAN VIEW
NEW MANHOLES

DROP BOWL
MOUNTING POSITION

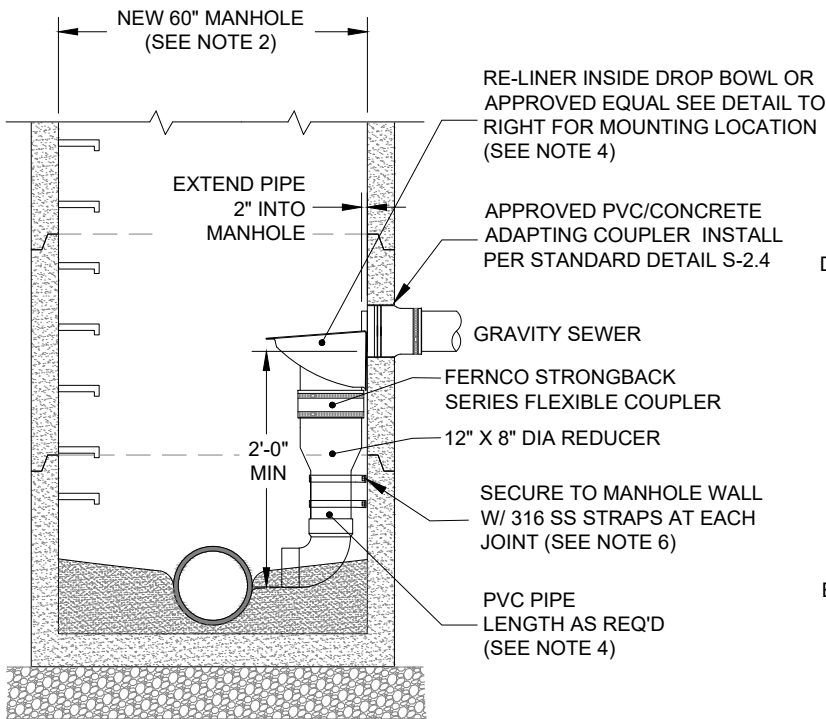

PROFILE VIEW
NEW MANHOLES

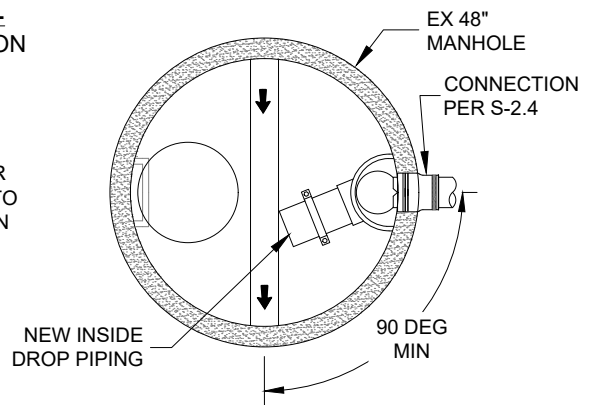

PLAN VIEW
EXISTING MANHOLES

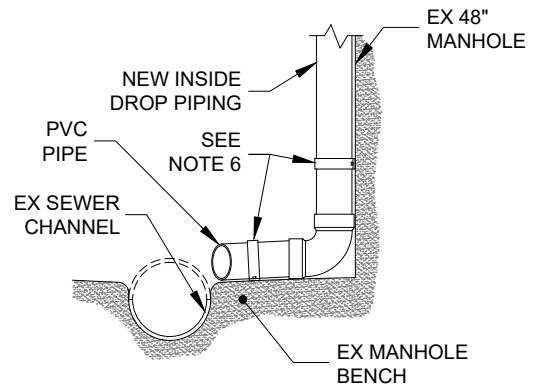

PROFILE VIEW
EXISTING MANHOLES

NOTES

- INSIDE DROP ASSEMBLY MAY BE USED ONLY WHEN SPECIFICALLY APPROVED BY COV SEWER ENGINEERING, MAX OF ONE (1) ASSEMBLY PER MANHOLE.
- NEW MANHOLES WITH AN INSIDE DROP ASSEMBLY SHALL BE A 60" ECCENTRIC CONE MANHOLE, COLUMBIA PRECAST OR APPROVED EQUAL.
- CONNECTING TO EXISTING MANHOLE W/ INSIDE DROP SHALL BE APPROVED BY COV SEWER ENGINEERING.
- RE-LINER BOWL OUTLET DIA SHALL BE SIZED TO MATCH INCOMING GRAVITY SEWER PIPE.
- ORIENT CONE AND LADDER STEPS TO NOT INTERFERE WITH MAINTENANCE OF DROP CONNECTION.
- SECURE TO MANHOLE WALL/ BENCH WITH MIN 1-1/2" 16GA 316 SS STRAPS AT EACH JOINT, USE 1/4"x 4" LG 316 SS EXPANSION ANCHORS W/ 316 SS BOLTS.

N.T.S.



STANDARD INSIDE DROP CONNECTION

CITY OF VANCOUVER
DEPARTMENT OF PUBLIC WORKS
SANITARY SYSTEMS PLANNING AND DESIGN

DRAWN BY	APPROVED BY	APPROVAL DATE
ANM	SLH	01 - 2025
REVISION	APPROVED BY	APPROVAL DATE
-	-	-

SEWER
DETAIL NO.

S-2.5A
SHEET: 1 OF 2

NOTES

1. BEAVER SLIDES ARE TO BE USED **ONLY** WHEN DIRECTED OR APPROVED BY THE CITY.
2. MAXIMUM ONE (1) BEAVER SLIDE PER MANHOLE.
3. ALL DROPS 24" OR GREATER SHALL BE AN INSIDE BOWL DROP CONNECTION PER DETAIL S-2.5A
4. CONCRETE SHALL BE 3000PSI MINIMUM
5. REFER TO SEWER DETAILS S-2.1A & S-2.4 FOR ADDITIONAL MANHOLE CONSTRUCTION REQUIREMENTS AND SEC 3-3.02 FOR ADDITIONAL DESIGN REQUIREMENTS

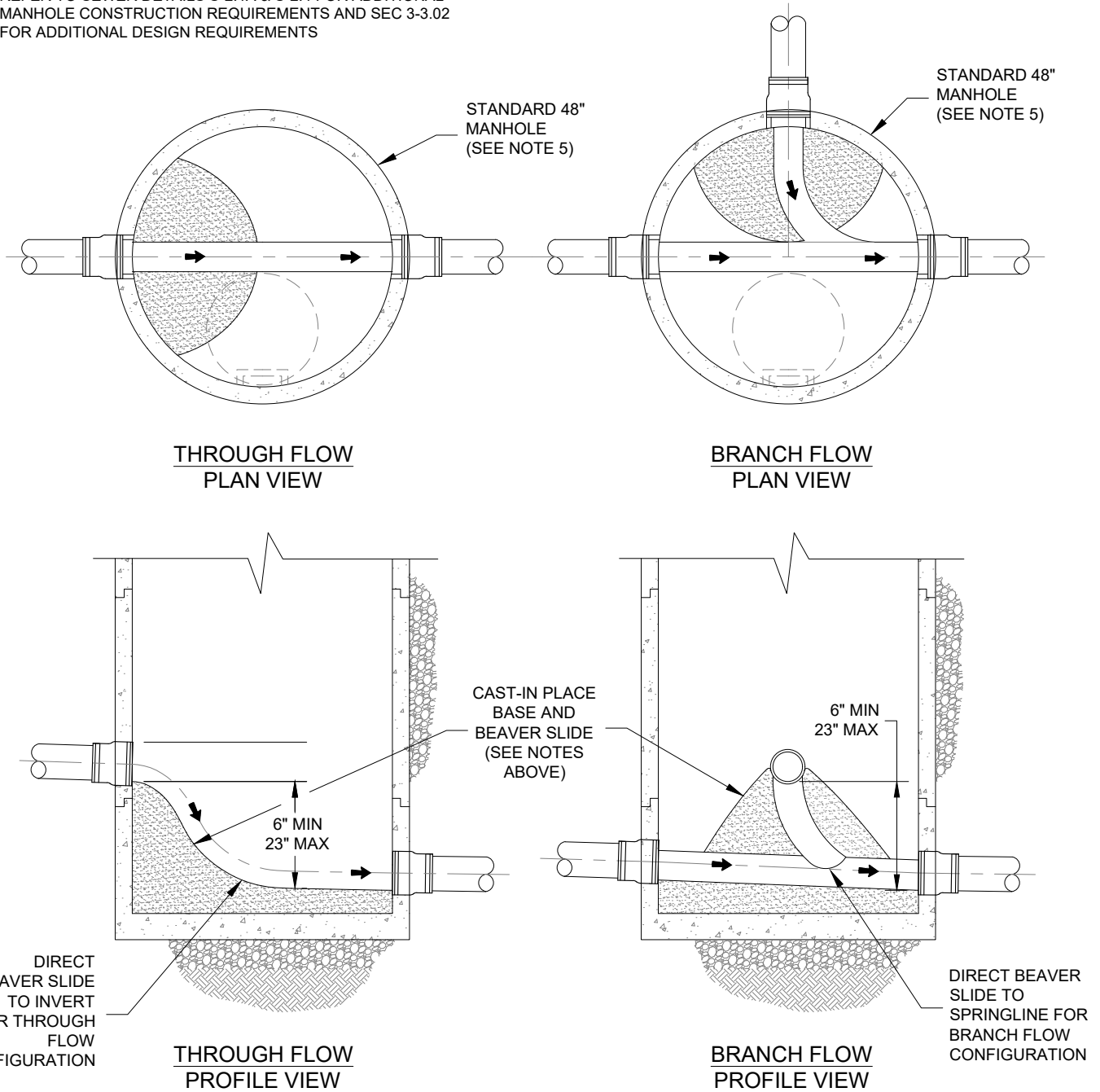

N.T.S.



BEAVER SLIDE DROP CONNECTION

CITY OF VANCOUVER
DEPARTMENT OF PUBLIC WORKS
SANITARY SYSTEMS PLANNING AND DESIGN

DRAWN BY	APPROVED BY	APPROVAL DATE
BTC	SLH	01 - 2025
REVISION	APPROVED BY	APPROVAL DATE
-	-	-

SEWER
DETAIL NO.
S-2.5B
SHEET: 2 OF 2

NOTES

1. SEAL THE MANHOLE JOINTS AND FRAME WITH INFI-SHIELD "SEAL WRAP" EXTERNAL SEAL SYSTEM OR APPROVED EQUAL
2. GROUTING FOR SEALING JOINTS SHALL BE FIVE-STAR, SIKA 212, EUCO N5, OR APPROVED NON-SHRINK GROUT. STANDARD GROUT WILL NOT BE ACCEPTED.

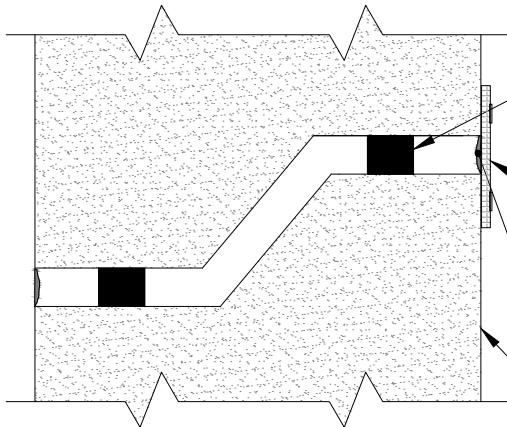

TONGUE & GROOVE

MASTIC
(2 ROWS)

SEAL ALL JOINTS WITH
INFI-SHIELD SEAL WRAP
(SEE NOTE 1)

FINISH SURFACE OF JOINT WITH WATER
TIGHT GROUT, STRIKE EVEN WITH WALL
(TYP ALL JOINTS)

EXTERIOR OF
MANHOLE

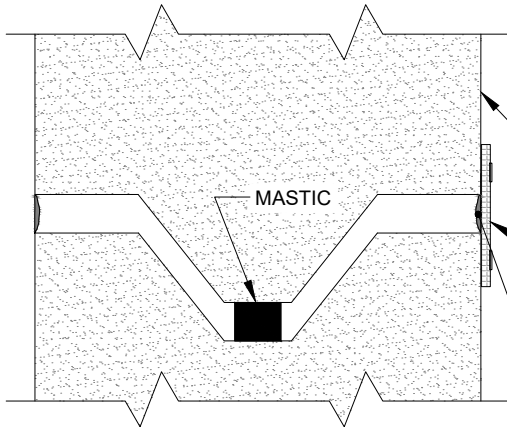

KEYLOCK

EXTERIOR OF
MANHOLE

SEAL ALL JOINTS WITH
INFI-SHIELD SEAL WRAP
(SEE NOTE 1)

FINISH SURFACE OF JOINT WITH WATER
TIGHT GROUT, STRIKE EVEN WITH WALL
(TYP ALL JOINTS)

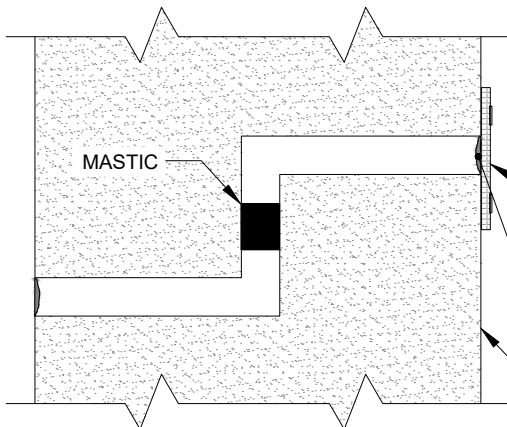

RUBBER JOINT GASKET

SEAL ALL JOINTS WITH
INFI-SHIELD SEAL WRAP
(SEE NOTE 1)

FINISH SURFACE OF JOINT WITH WATER
TIGHT GROUT, STRIKE EVEN WITH WALL
(TYP ALL JOINTS)

EXTERIOR OF
MANHOLE

N.T.S.

STANDARD MANHOLE JOINTS

SEWER
DETAIL NO.



CITY OF VANCOUVER
DEPARTMENT OF PUBLIC WORKS
SANITARY SYSTEMS PLANNING AND DESIGN

DRAWN BY	APPROVED BY	APPROVAL DATE
BTC	SLH	01 - 2025
REVISION	APPROVED BY	APPROVAL DATE
-	-	-

S-2.6

NOTES:

1. RISER PIPE SHALL BE 6" ASTM D3034 SDR 35 PVC PIPE
2. VALVE BOX SHALL BE "VANCOUVER 910".
3. THERE SHALL BE 1/2" CLEARANCE UNDER THE PIN CAST INTO THE LID.
4. CONCRETE COLLAR SHALL BE MINIMUM STRENGTH OF 3000PSI
5. PIPE BEDDING SHALL CONFORM TO SEWER STANDARD DETAIL S-1.2.
6. FOR LATERAL STUB MARKERS; 4" LATERALS WILL USE 4"X4"X4" TEE WITH A 4" RISER.
6" LATERALS WILL USE A 6"X6"X4" TEE WITH A 4" RISER.
7. CONCRETE COLLAR REQUIRED FOR VALVE BOXES PLACED IN UNPAVED AREAS.
8. STUB MARKERS FOR MAINS 8" OR GREATER SHALL REQUIRE A PROFILE ON CIVIL PLANS FOR CITY REVIEW AND APPROVAL.

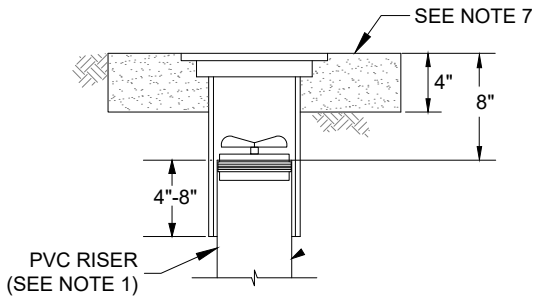

**SEWER PLUG
DETAIL VIEW**

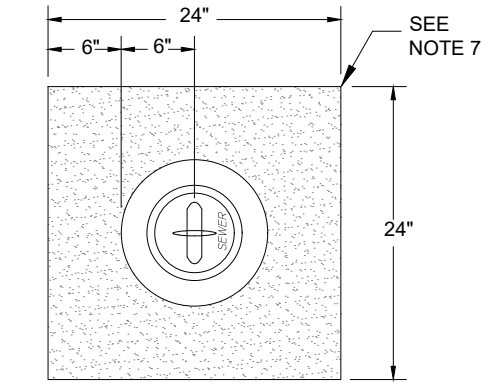

**SEWER CONCRETE PAD
PLAN VIEW**

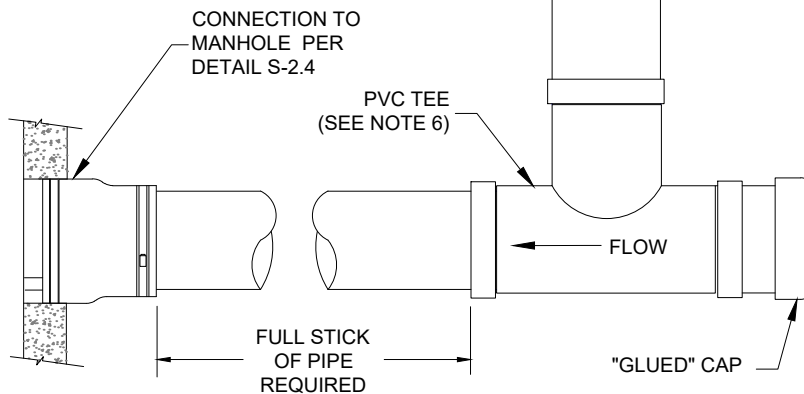
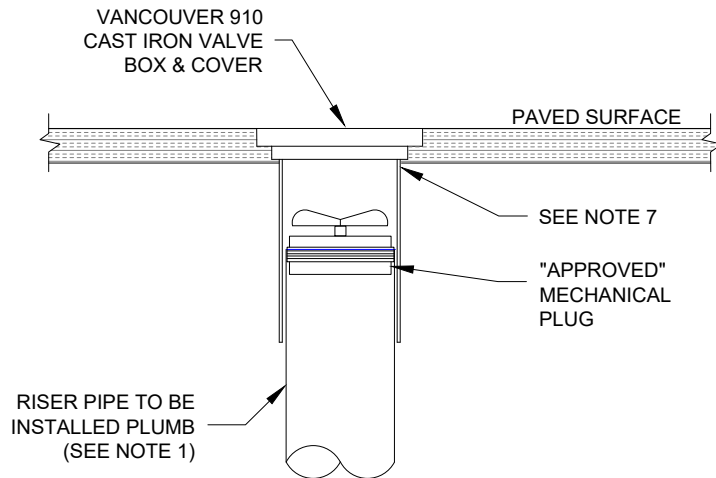

**STUB-MARKER
PROFILE VIEW**

N.T.S.



STANDARD GRAVITY SEWER STUB MARKER

CITY OF VANCOUVER
DEPARTMENT OF PUBLIC WORKS
SANITARY SYSTEMS PLANNING AND DESIGN

DRAWN BY	APPROVED BY	APPROVAL DATE
BTC	SLH	01 - 2025
REVISION	APPROVED BY	APPROVAL DATE
-	-	-

SEWER
DETAIL NO.
S-3.0

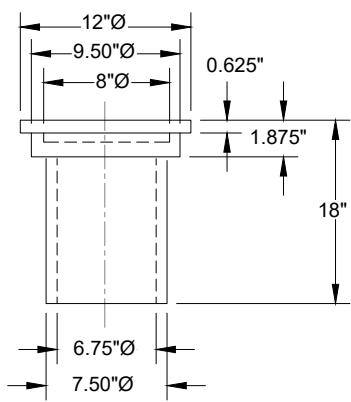
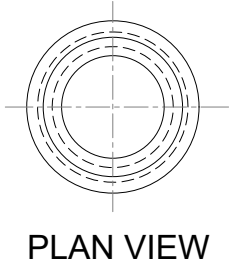
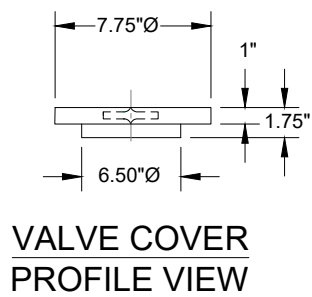
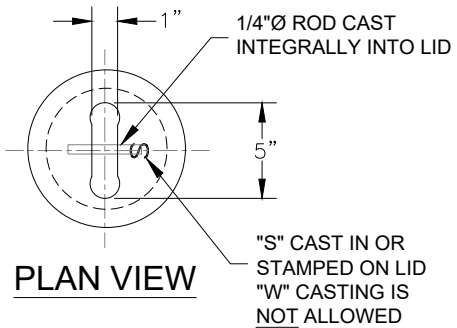

- NOTES**
1. VALVE BOX SHALL BE FORT VANCOUVER PATTERN NO 910 CAST IRON OR APPROVED EQUAL.
 2. MATERIAL TO BE GREY CAST IRON CONFORMING TO ASTM A46 CLASS 30.
 3. CLEANOUT PIPE TYPE TO MATCH MAINLINE.
 4. CONCRETE COLLAR REQUIRED FOR CLEANOUTS LOCATED IN UNPAVED AREAS (SEE S-3.0 FOR CONCRETE DETAILS).

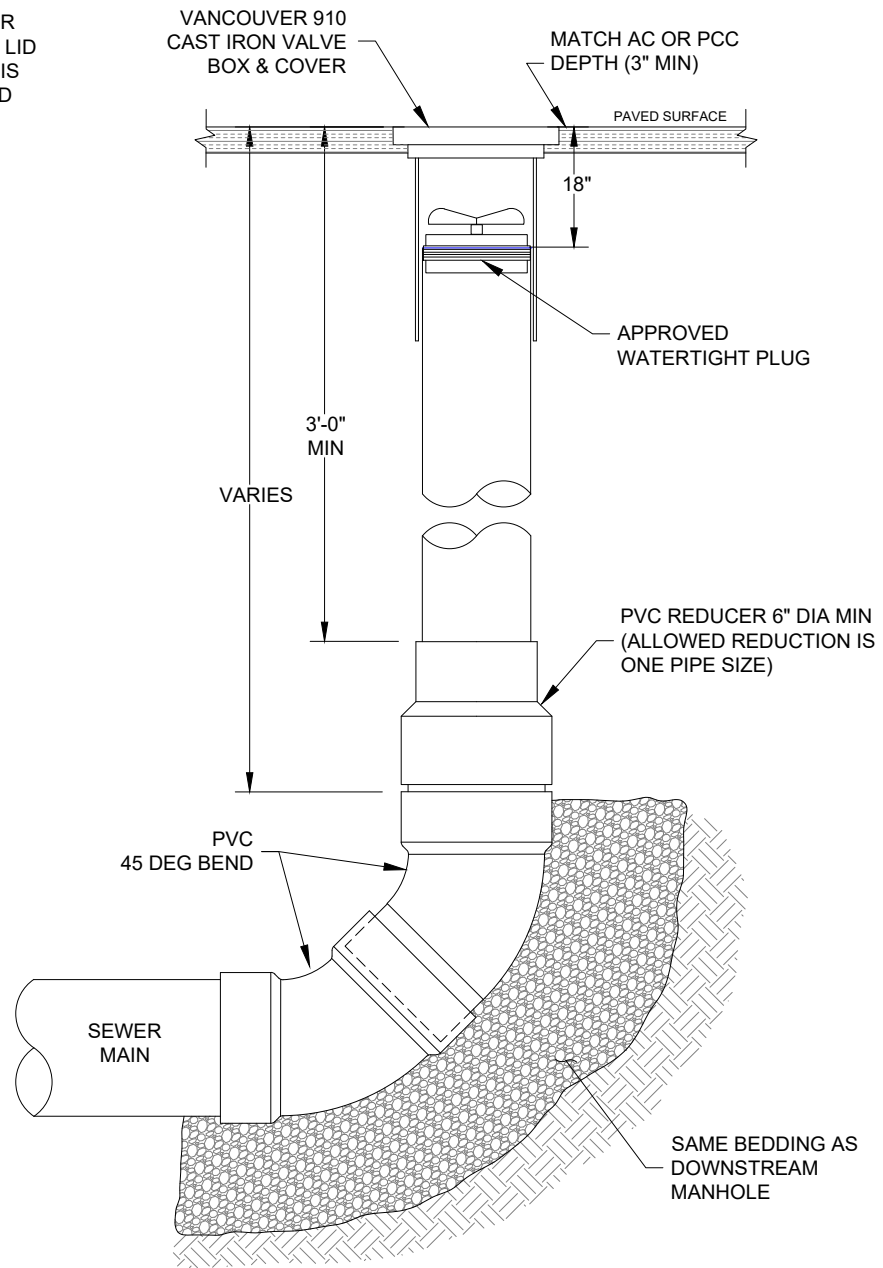

CAST IRON VALVE BOX PROFILE VIEW

SEWER CLEANOUT PROFILE VIEW

N.T.S.



STANDARD GRAVITY SEWER CLEANOUT

CITY OF VANCOUVER
DEPARTMENT OF PUBLIC WORKS
SANITARY SYSTEMS PLANNING AND DESIGN

DRAWN BY	APPROVED BY	APPROVAL DATE
BTC	SLH	01 - 2025
REVISION	APPROVED BY	APPROVAL DATE
-	-	-

SEWER
DETAIL NO.
S-3.1

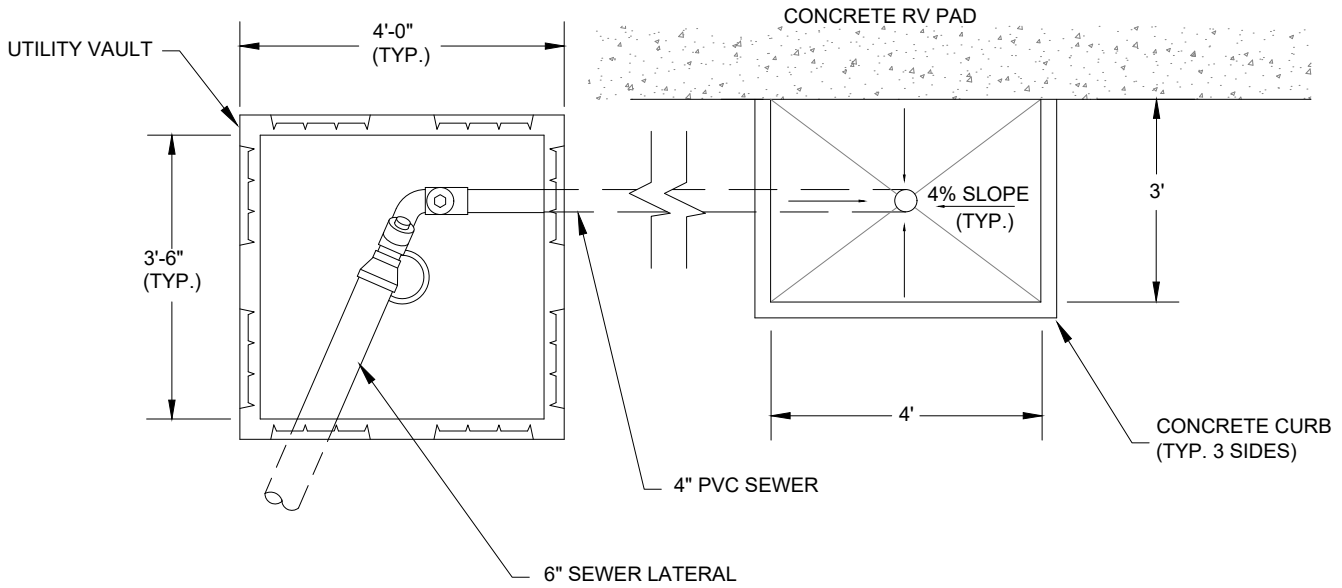

PLAN VIEW

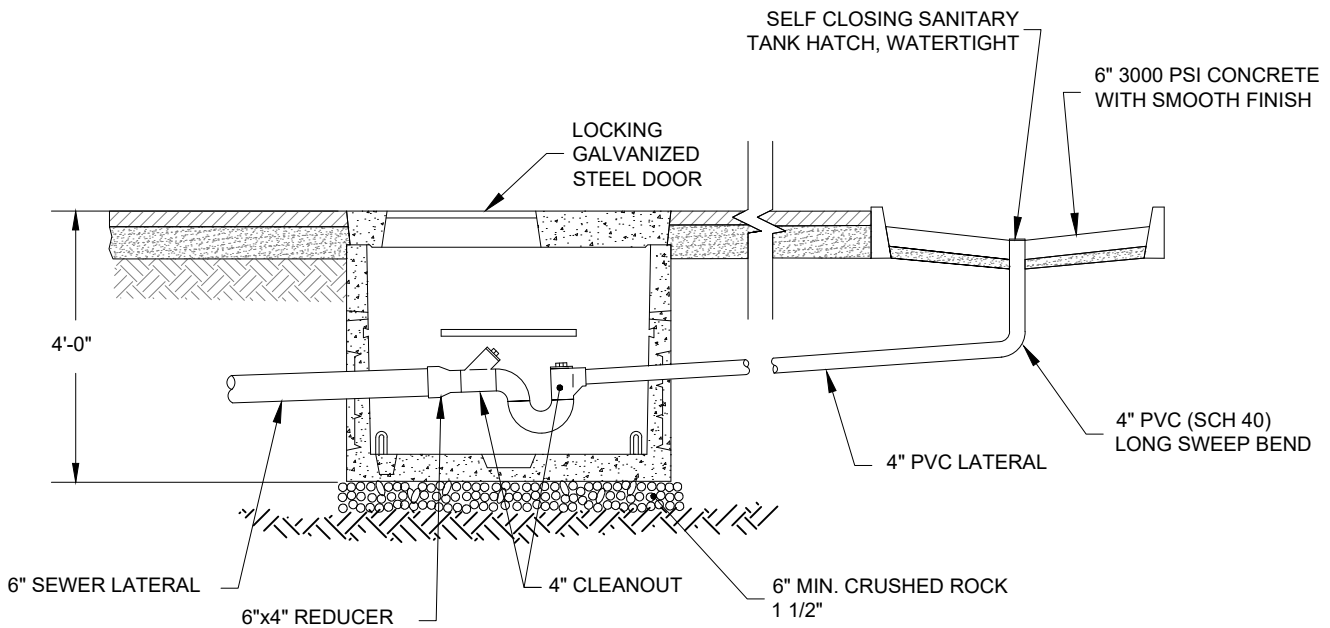

PROFILE VIEW

NOTES:

1. APPROVED VAULT SHALL BE UTILITY VAULT CO. 444-LA WITH COVER NO. 44-38C, OR PIPE ENTERPRISES, INC. 444-13 WITH COVER NO. 440-13.
2. ALL ONSITE PLUMBING IS GOVERNED BY THE BUILDING DEPARTMENT PLUMBING CODE. PERMITS AND INSPECTIONS ARE REQUIRED.

N.T.S.



RV SEWER DISPOSAL STATION - COMMERCIAL

CITY OF VANCOUVER
DEPARTMENT OF PUBLIC WORKS
SANITARY SYSTEMS PLANNING AND DESIGN

DRAWN BY	APPROVED BY	APPROVAL DATE
BTC	SLH	01 - 2025
REVISION	APPROVED BY	APPROVAL DATE
-	-	-

SEWER
DETAIL NO.
S-3.2

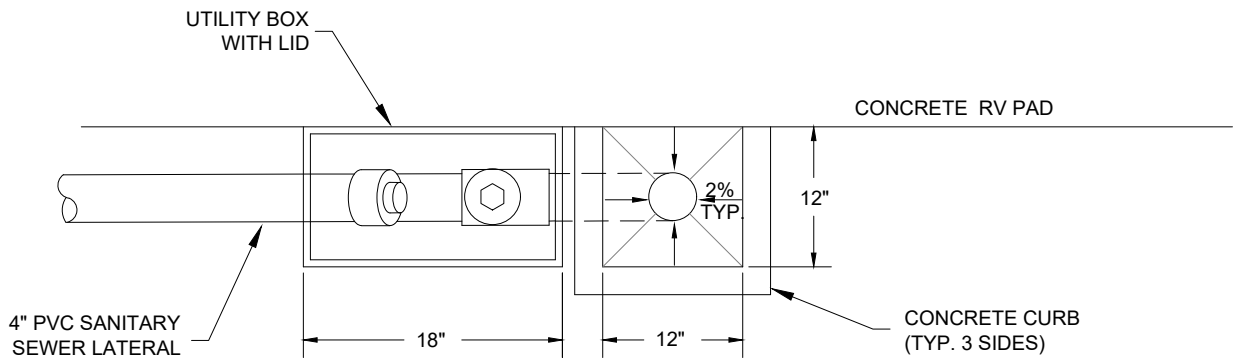

PLAN VIEW

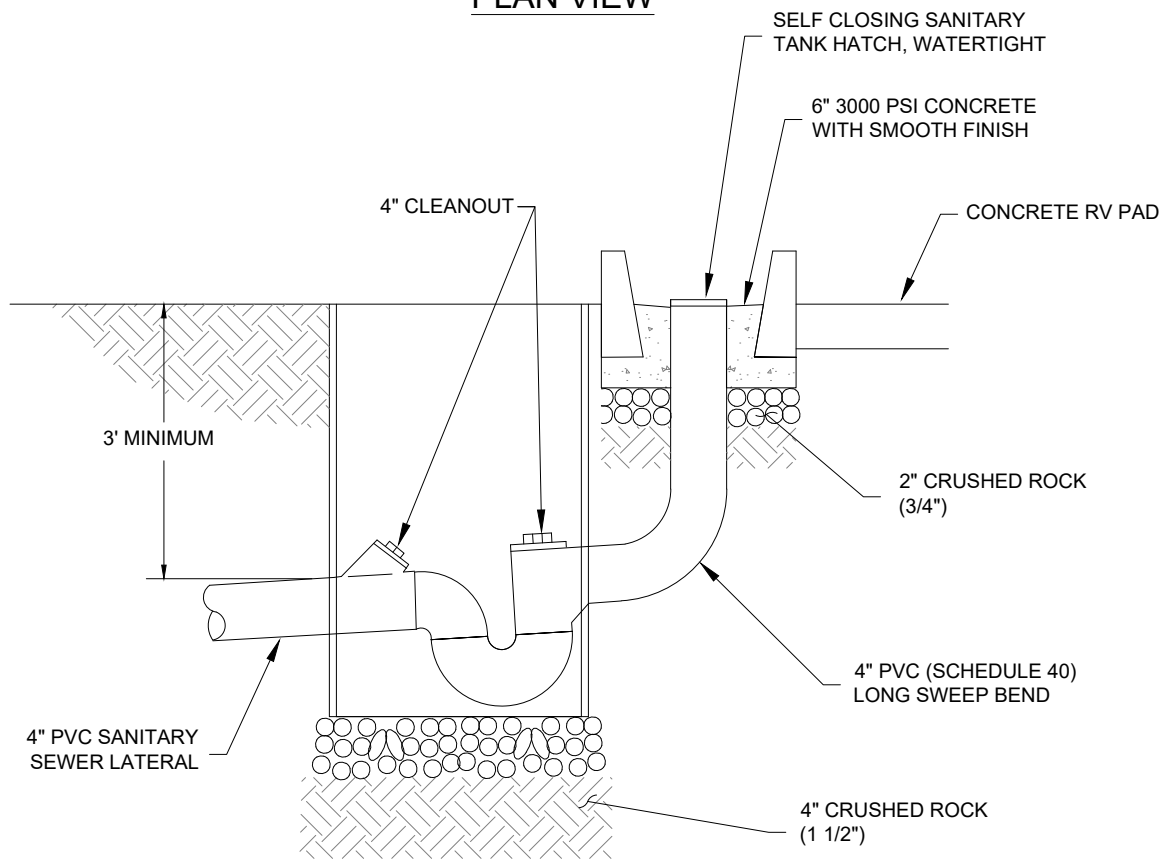

PROFILE VIEW

NOTES:

1. ALL ONSITE PLUMBING IS GOVERNED BY THE BUILDING DEPARTMENT PLUMBING CODE. PERMITS AND INSPECTIONS ARE REQUIRED.

N.T.S.



RV SEWER DISPOSAL STATION - RESIDENTIAL

CITY OF VANCOUVER
DEPARTMENT OF PUBLIC WORKS
SANITARY SYSTEMS PLANNING AND DESIGN

DRAWN BY	APPROVED BY	APPROVAL DATE
BTC	SLH	01 - 2025
REVISION	APPROVED BY	APPROVAL DATE
-	-	-

SEWER
DETAIL NO.
S-3.3

NOTES

- SERVICE LATERALS GREATER THAN 6" SHALL FOLLOW S-3.5

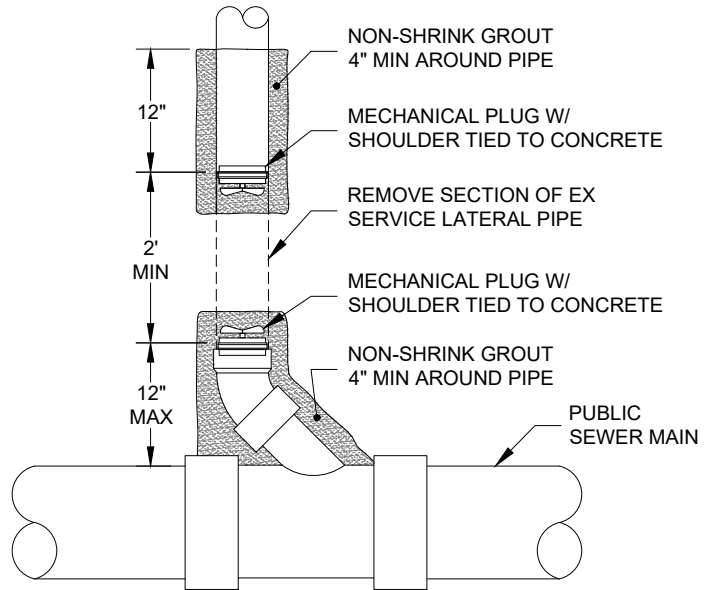

**SERVICE LATERAL CONNECTION AT MAIN
DETAIL**

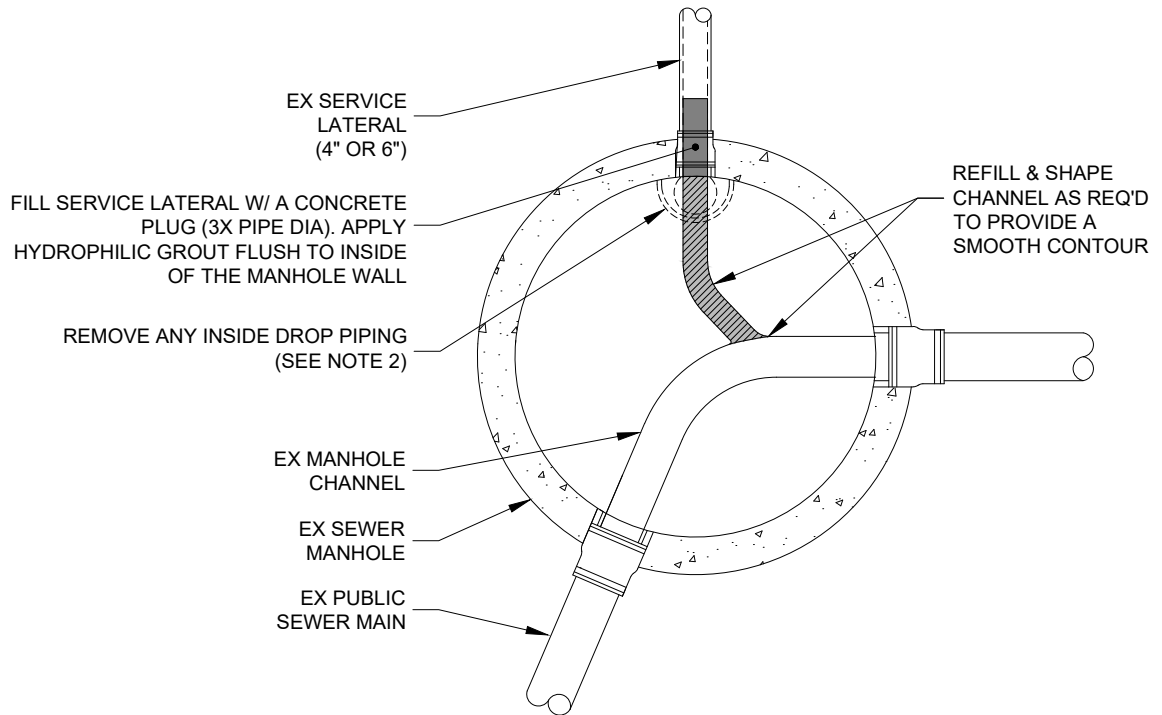

**SERVICE LATERAL CONNECTION AT MANHOLE
DETAIL**

N.T.S.



SEWER SERVICE LATERAL ABANDONMENT

CITY OF VANCOUVER
DEPARTMENT OF PUBLIC WORKS
SANITARY SYSTEMS PLANNING AND DESIGN

DRAWN BY	APPROVED BY	APPROVAL DATE
BTC	SLH	01 - 2025
REVISION	APPROVED BY	APPROVAL DATE
-	-	-

SEWER
DETAIL NO.
S-3.4

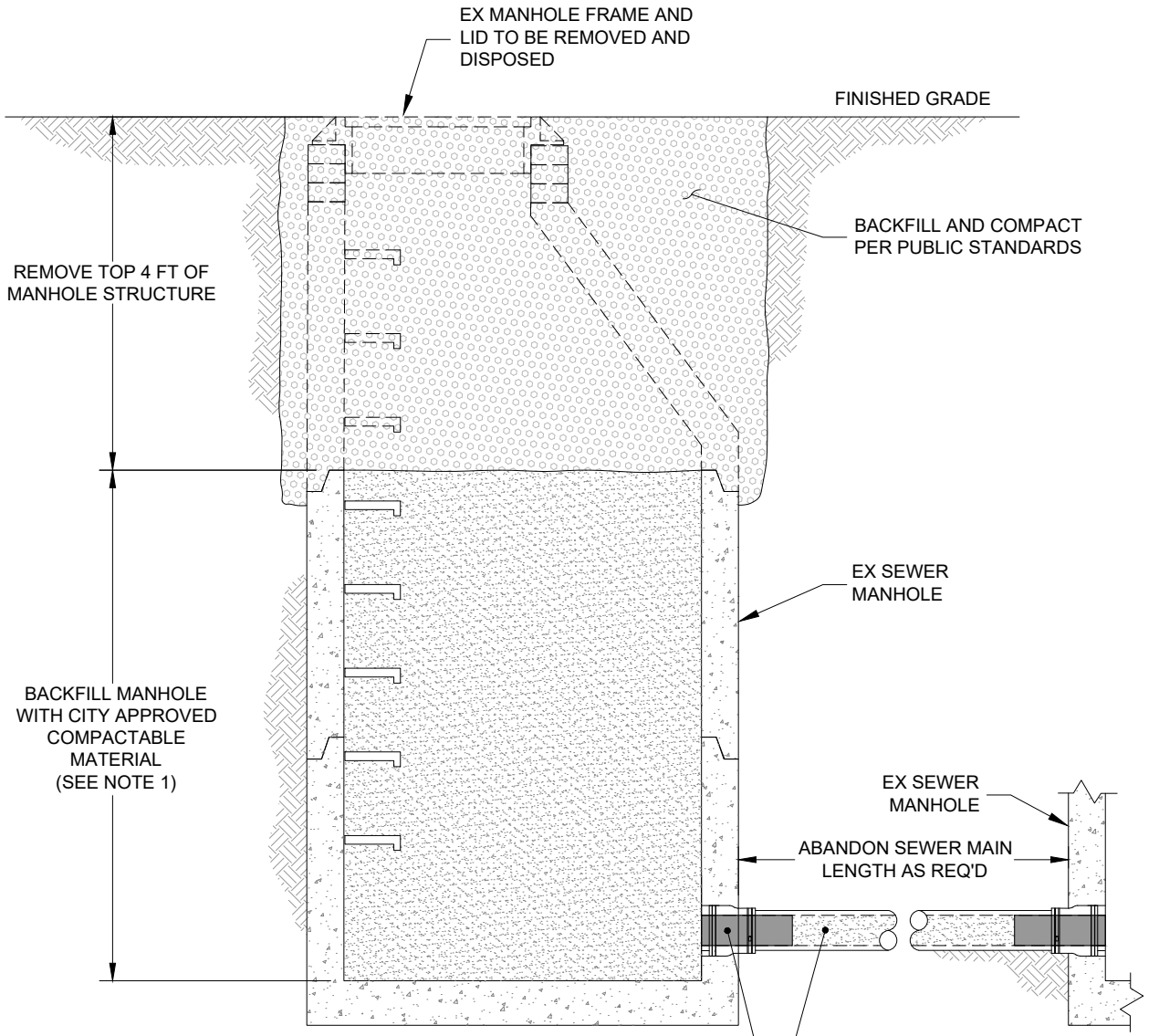

PROFILE VIEW

NOTES

1. THE CITY MAY REQUIRE CDF BACKFILL FOR ABANDONMENT OF ANY MANHOLES LOCATED WITHIN A MAJOR ARTERIAL.
2. SEWER MAINS SHALL BE DECOMMISSIONED BY PLUGGING THE ENDS WITH PORTLAND CEMENT CONCRETE AFTER THEY ARE FLUSHED. THE CONCRETE PLUGS SHALL EXTEND INTO THE PIPE FROM THE PIPE ENDS A MINIMUM DISTANCE OF THREE (3) TIMES THE INSIDE DIAMETER OF THE PIPE.
3. IF ANY SEWER MAINS OR SERVICE LATERALS ENTER BY INSIDE BOWL DROP, THE CONTRACTOR IS RESPONSIBLE FOR REMOVING ALL PIPING OUT OF THE MANHOLE AND PLUGGING ALL PENETRATIONS BEFORE ABANDONMENT

BACKFILL EX SEWER PIPE WITH CITY APPROVED SAND SLURRY MIX (SEE NOTE 2)

PLUG LENGTH FOR SEWER PIPE ABANDONMENT SHALL BE THREE (3) TIMES THE HOST PIPE DIAMETER (SEE NOTE 3)

N.T.S.



SEWER MANHOLE & SEWER MAIN ABANDONMENT

CITY OF VANCOUVER
DEPARTMENT OF PUBLIC WORKS
SANITARY SYSTEMS PLANNING AND DESIGN

DRAWN BY	APPROVED BY	APPROVAL DATE
BTC	SLH	01 - 2025
REVISION	APPROVED BY	APPROVAL DATE
-	-	-

SEWER
DETAIL NO.
S-3.5

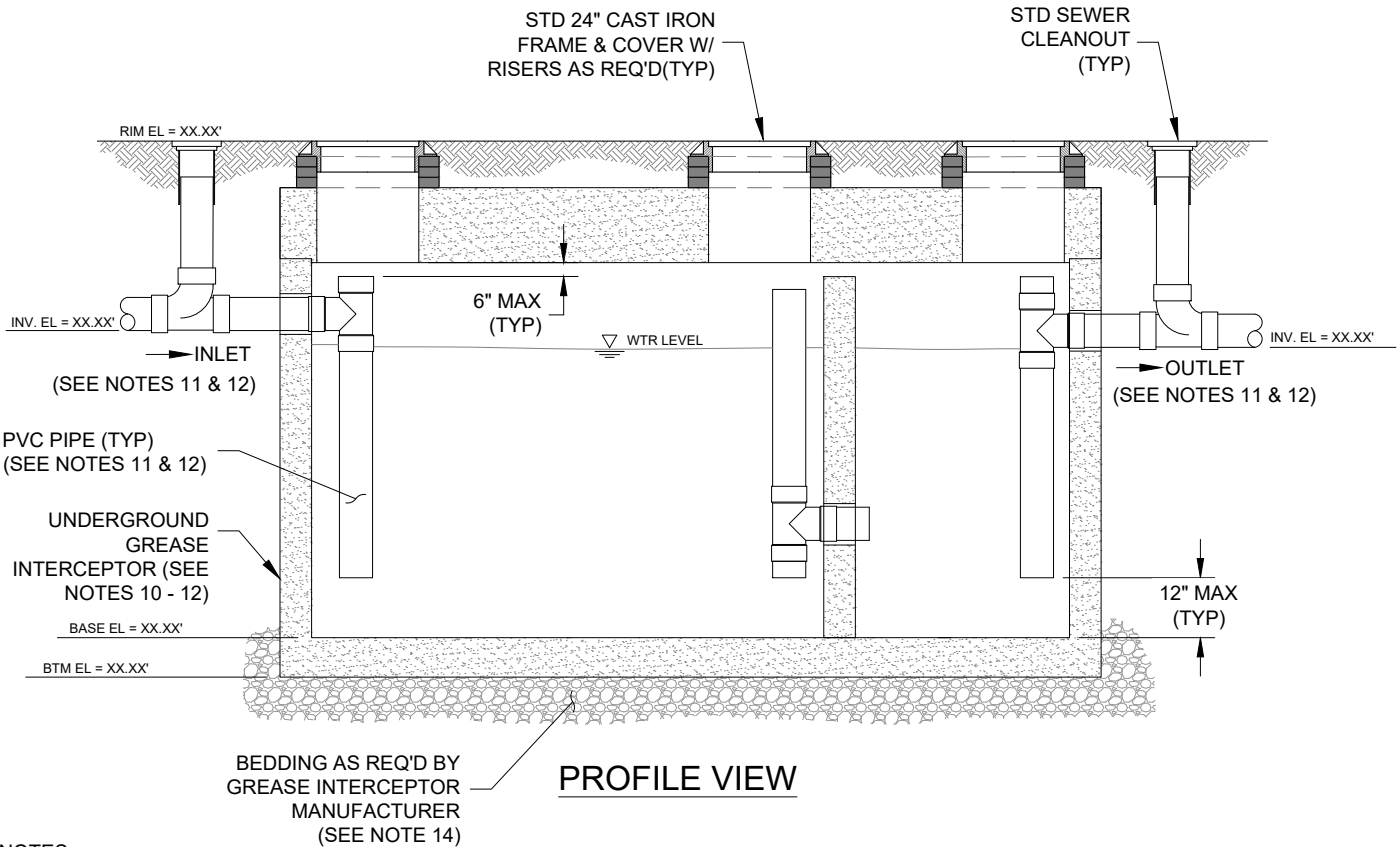

NOTES:

1. REFER TO UNIFORM PLUMBING CODE FOR ADDITIONAL VENTING REQUIREMENTS.
2. A BUILDING DEPARTMENT PLUMBING PERMIT IS REQUIRED.
3. DURING CONSTRUCTION SPECIAL INSPECTION IS REQUIRED FOR INSTALLATION OF THE SANITARY SEWER GREASE INTERCEPTORS. SATISFY THE BUILDING DEPARTMENT'S INITIAL PLUMBING REQUIREMENTS. A FINAL INSPECTION IS REQUIRED (SEE NOTE 4 BELOW).
4. FINAL INSPECTION: GREASE TRAPS/INTERCEPTORS ARE SUBJECT TO INSPECTION BY THE BUILDING DEPARTMENT AND THE CITY OIL AND GREASE MANAGEMENT STAFF.
5. POSITION RISERS BELOW AND OFF-CENTER OF MANHOLES TO ALLOW ACCESS AND ENTRY.
6. NO CONCRETE PLUGS BELOW CAST IRON MANHOLE COVERS.
7. PLACE INTERCEPTOR IN LOCATION WHICH ALLOWS FOR PUMP TRUCK/MAINTENANCE ACCESS.
8. FILL WITH CLEAN WATER PRIOR TO START-UP AND AFTER PUMP OUTS
9. BLACK WATER ONLY. DOMESTIC (SANITARY) WATER SHALL BE CONVEYED BY SEPARATE LINE
10. MINIMUM CAPACITY IS 1000 GAL. FOR CAPACITIES EQUAL TO OR GREATER THAN 1,500 GALLONS, A CENTER MANHOLE IS REQUIRED AND THE COVER SHALL BE A STANDARD 24" DIAMETER COVER.
11. TANKS 4,000 GAL OR LESS SHALL HAVE 4-INCH DIAMETER PIPING.
12. TANKS EXCEEDING 4,000 GAL SHALL HAVE 6-INCH DIAMETER PIPING.
13. UNIT SHALL BE RATED FOR AASHTO LOADING. (CERTIFIED)
14. IF GREASE INTERCEPTOR IS LOCATED WITHIN PUBLIC RIGHT OF WAY, COMPACTION PER SECTION 9-03.12(3) IS REQUIRED.

THE CITY OF VANCOUVER'S
OIL AND GREASE MANAGEMENT
CONTACT INFORMATION:

JON MORGAN (360) 921-4551
OR
JOHN HONRATH (360) 607-1573

N.T.S.



STANDARD GREASE INTERCEPTOR

CITY OF VANCOUVER
DEPARTMENT OF PUBLIC WORKS
SANITARY SYSTEMS PLANNING AND DESIGN

DRAWN BY	APPROVED BY	APPROVAL DATE
BTC	FAD	01 - 2025
REVISION	APPROVED BY	APPROVAL DATE
-	-	-

SEWER
DETAIL NO.
S-4.0

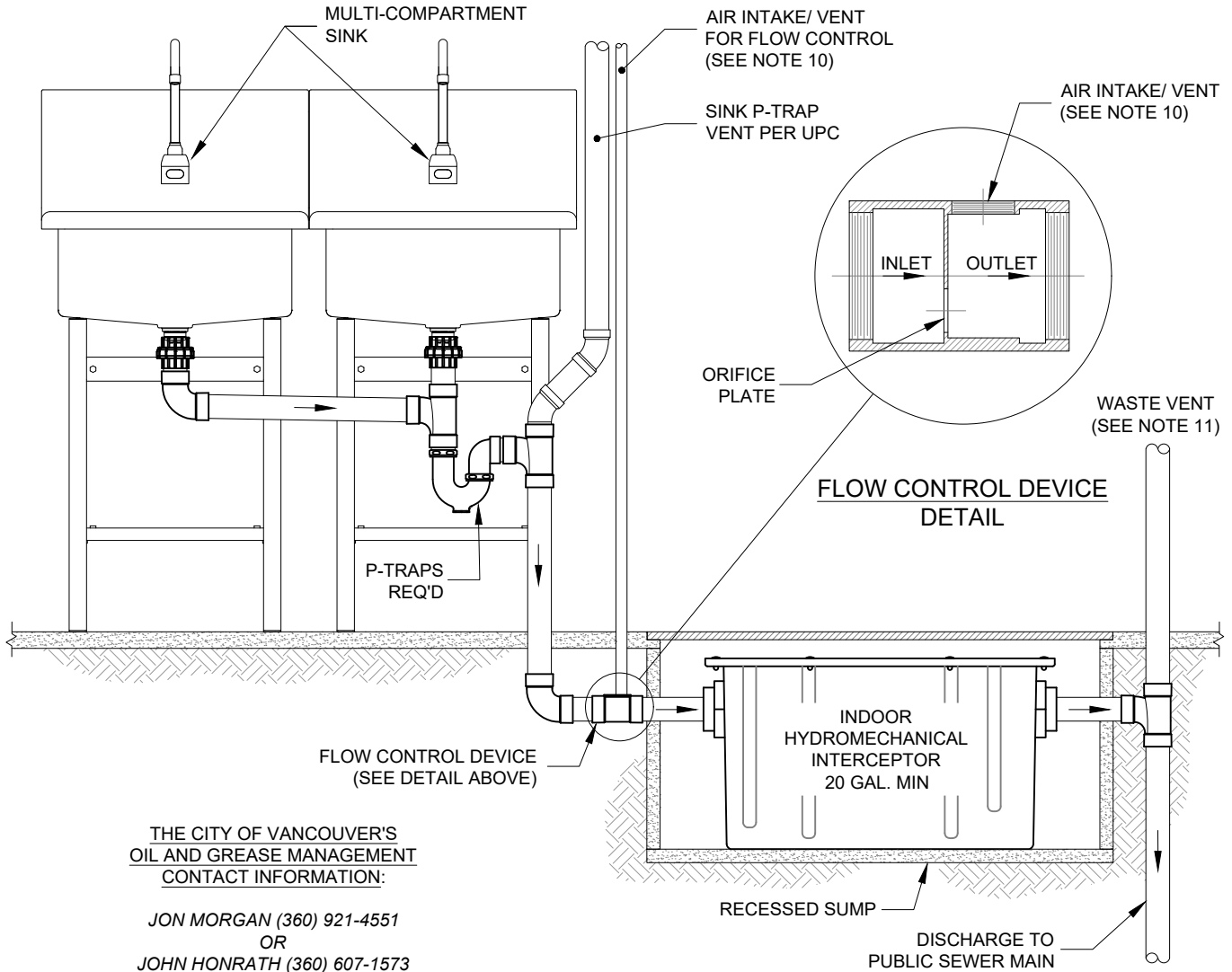

THE CITY OF VANCOUVER'S
OIL AND GREASE MANAGEMENT
CONTACT INFORMATION:

JON MORGAN (360) 921-4551
OR
JOHN HONRATH (360) 607-1573

PROFILE VIEW

NOTES:

1. A FLOW CONTROL DEVICE IS REQUIRED.
2. MINIMUM TANK SIZE SHALL BE NO LESS THAN 20 GALLONS.
3. FOOD WASTE DISPOSAL UNITS SHALL NOT DISCHARGE TO A HYDROMECHANICAL GREASE INTERCEPTOR.
4. ALLOW A MINIMUM 6-INCH CLEARANCE AROUND DEVICE FOR REMOVING THE LID.
5. PER UPC 1014.3.4.1 NO HGI SHALL BE INSTALLED IN ANY PART OF THE BUILDING WHERE FOOD IS TO BE HANDLED.
6. PER UPC A P-TRAP SHALL BE USED ON EACH FIXTURE
7. ALL ONSITE PLUMBING IS GOVERNED BY THE BUILDING DEPARTMENT PLUMBING CODE.
8. PERMITS AND INSPECTIONS ARE REQUIRED.
9. SIZE REQUIRED GREASE INTERCEPTORS AS REQUIRED BY THE PLUMBING CODE AND CITY OIL & GREASE MANAGEMENT STAFF.
10. CONNECT FLOW CONTROL AIR INTAKE TO SANITARY VENT SYSTEM OR TERMINATE THROUGH THE ROOF OF THE BLDG PER UPC. THIS INTAKE SHALL NOT BE VENTED TO THE FREE BLDG ATMOSPHERE.
11. WASTE VENT CAN TIE INTO COMMON BLDG VENT 6-INCHES ABOVE FLOOD LEVEL OR TO ROOF VENT.

N.T.S.



INDOOR HYDROMECHANICAL GREASE INTERCEPTOR

CITY OF VANCOUVER
DEPARTMENT OF PUBLIC WORKS
SANITARY SYSTEMS PLANNING AND DESIGN

DRAWN BY	APPROVED BY	APPROVAL DATE
BTC	FAD	01 - 2025
REVISION	APPROVED BY	APPROVAL DATE
-	-	-

SEWER
DETAIL NO.

S-4.1

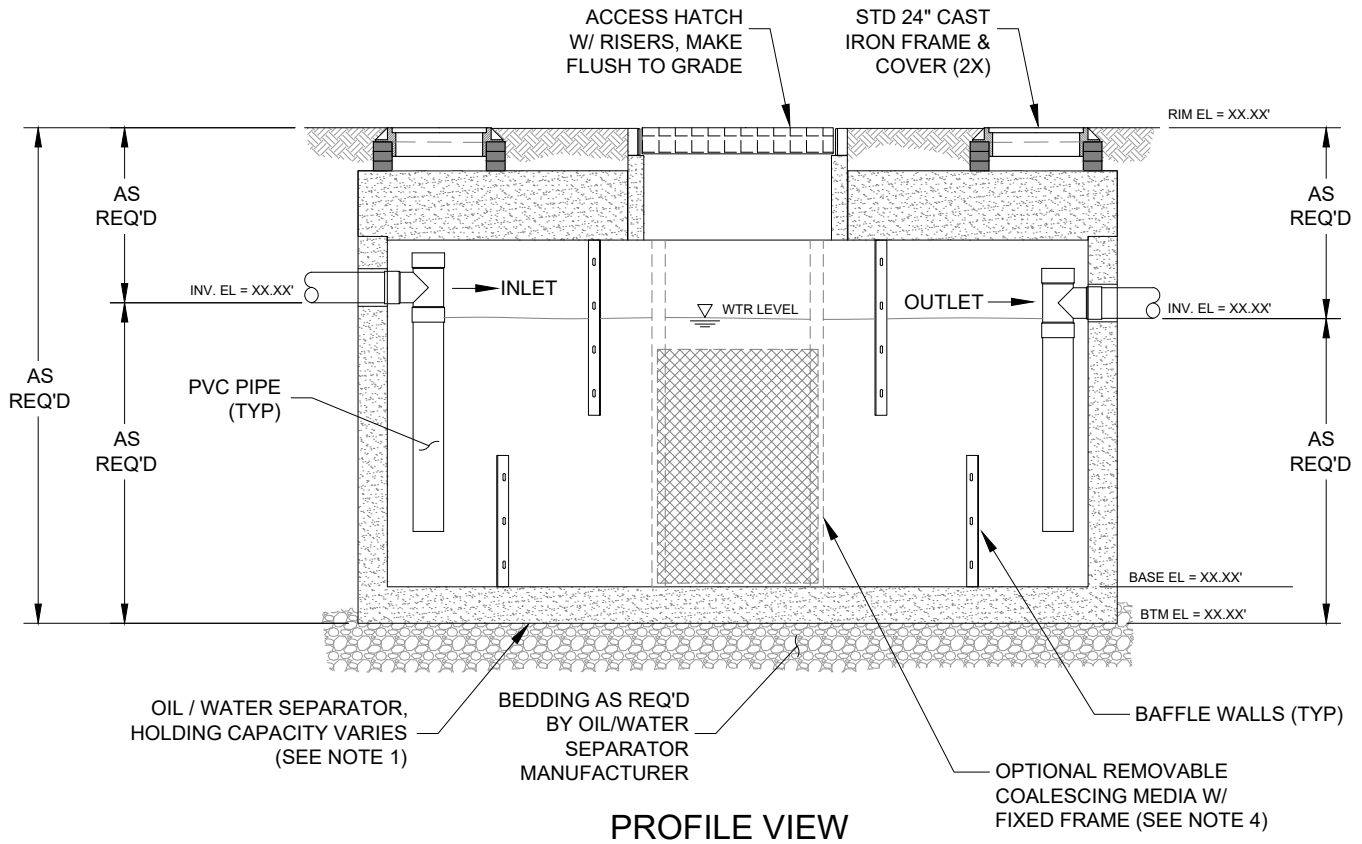

RECOMMENDED MANAGEMENT PRACTICES:

1. SIZE SEPARATOR FOR A 45 MINUTE RETENTION TIME AT PEAK FLOW, OR EQUIVALENT RETENTION IF USING COALESCING PLATES.
2. BEFORE INSTALLATION, SUBMIT ALL PLANS TO THE CITY'S INDUSTRIAL PRETREATMENT OFFICE FOR REVIEW. INDICATE ALL SOURCES OF WASTEWATER TO DEVICE AND PROVIDE ESTIMATES OF EXPECTED AVERAGE AND MAXIMUM FLOW RATES.
3. INSPECT SEPARATOR EVERY 6 MONTHS. USE A LONG STICK TO CHECK SLUDGE BUILDUP IN THE FIRST CHAMBER. HAVE SEPARATOR CLEANED IF SLUDGE BUILDUP IS OVER 8" INCHES OR IF THERE ARE MORE THAN 2" INCHES OF OIL FLOATING ON THE SURFACE IN ANY CHAMBER.
4. FOR COALESCING PLATE SEPARATOR, CLEAN THE PLATES BEFORE THEY BECOME COATED WITH SILT OR SOLIDS.
5. DO NOT ALLOW THE FOLLOWING TO ENTER THE SEPARATOR AS THEY WILL EMULSIFY THE OIL: ANTIFREEZE, DEGREASERS, DETERGENTS, ALCOHOL & SOLVENTS. ALSO, AVOID OVERLOADING THE SYSTEM WITH CONCENTRATED OILS OR HEAVY METAL-BEARING WASTEWATER.
6. TO REDUCE MAINTENANCE, REMOVE FLOATING OIL WITH ABSORBENT PADS OR VACUUM OUT OIL FILM. IF NECESSARY, INSTALL A CATCH BASIN BEFORE THE SEPARATOR TO REDUCE SLUDGE LOAD.
7. ALL ONSITE BUILDING SEWERS MUST MEET BUILDING DEPARTMENT STANDARDS. PERMITS AND INSPECTIONS ARE REQUIRED.

N.T.S.



STANDARD OIL / WATER SEPARATOR

CITY OF VANCOUVER
DEPARTMENT OF PUBLIC WORKS
SANITARY SYSTEMS PLANNING AND DESIGN

DRAWN BY	APPROVED BY	APPROVAL DATE
BTC	FAD	01 - 2025
REVISION	APPROVED BY	APPROVAL DATE
-	-	-

SEWER
DETAIL NO.
S-4.2

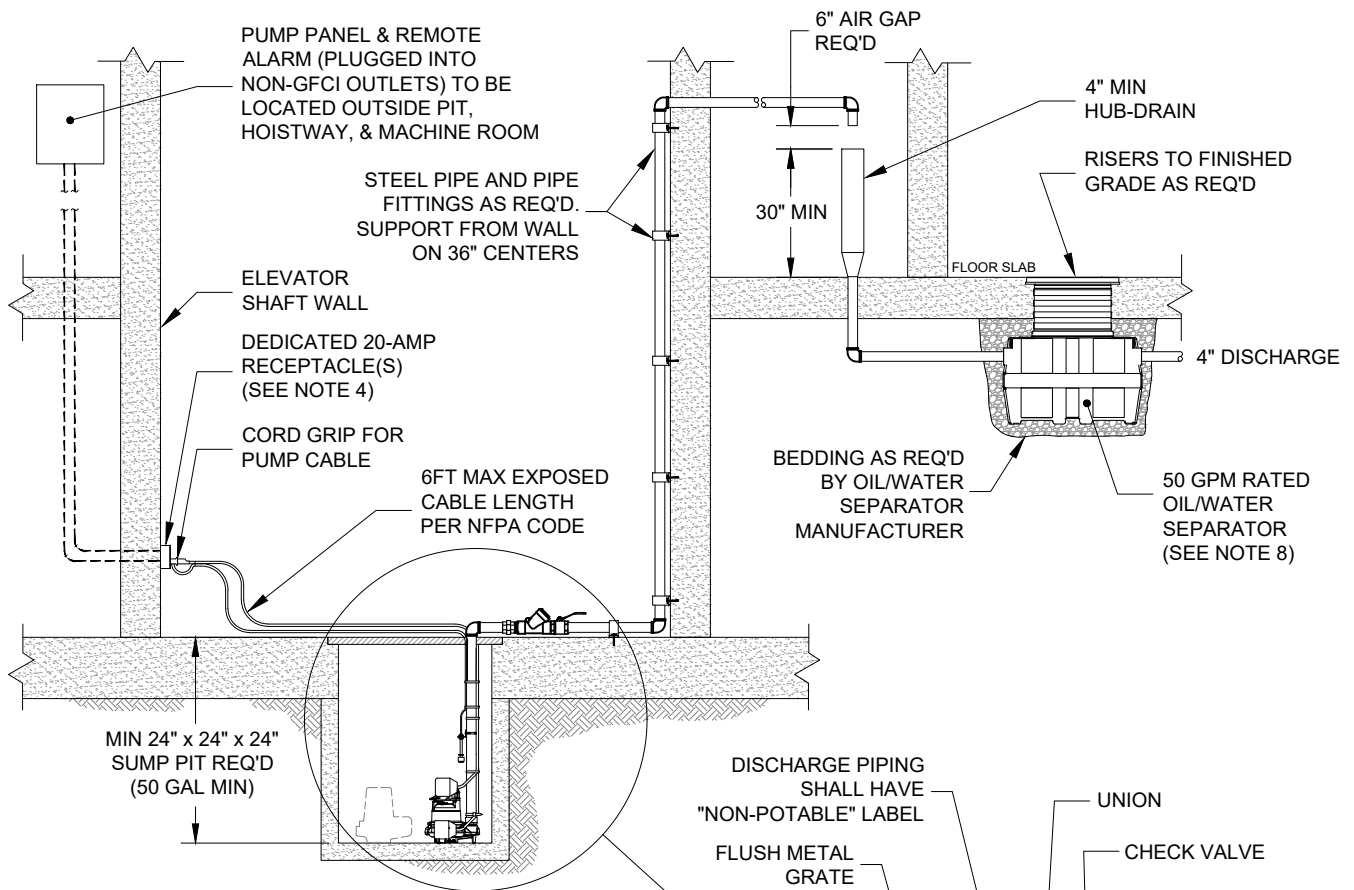

PROFILE VIEW

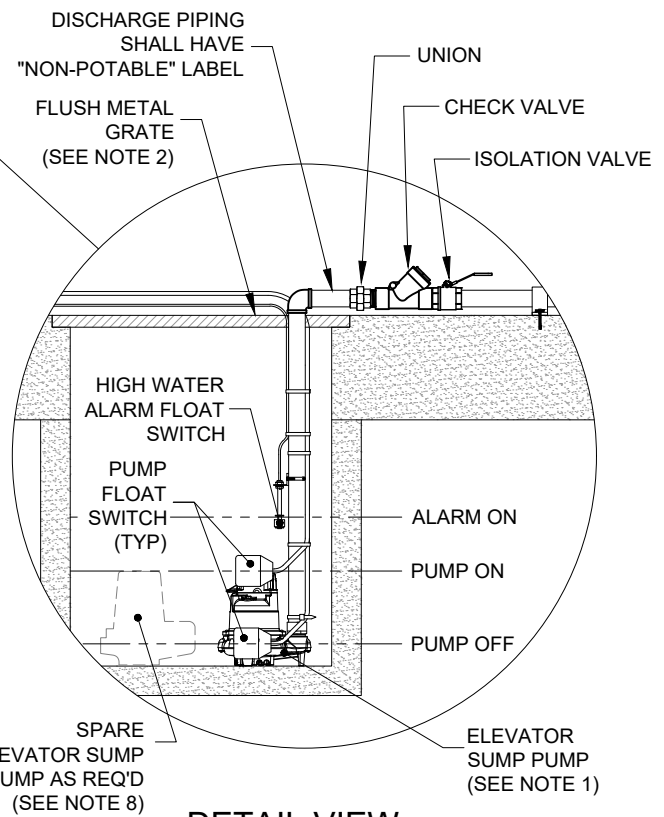

DETAIL VIEW

NOTES

1. SUMP PUMPS SHALL BE APPROVED BY THE MANUFACTURER FOR SPECIFIC USE IN ELEVATOR SHAFTS.
2. THE PUMP MUST BE LOCATED IN A SUMP HOLE WITH A GRATE COVER FLUSH WITH THE ELEVATOR PIT FLOOR CAPABLE OF WITHSTANDING 300LB WEIGHT.
3. HYDRAULIC FLUIDS & HAZARDOUS MATERIALS ARE NOT PERMITTED TO BE DRAINED TO PUBLIC SEWER.
4. DEDICATED 20AMP NON-GFCI OUTLET REQUIRED FOR ELEVATOR SUMP PUMP AND ALARM BOX.
5. SIGNAGE FOR AUDIBLE & VISUAL ALARM W/ FLOAT SWITCHES ARE REQUIRED.
6. PLUMBING INSIDE ELEVATOR SHAFT SHALL CONFORM TO ALL APPLICABLE BUILDING PLUMBING CODE.
7. ALL ELECTRICAL WORK SHALL CONFORM TO NATIONAL ELECTRIC CODE (NEC).
8. A SPARE PUMP MAY BE REQUIRED IN SOME CASES; SIZE OIL/WATER SEPARATOR TO ACCOMMODATE DUPLEX PUMP FLOWS
9. INSTALLATION TO COMPLY WITH CURRENT ELEVATOR CODE
10. DETAILS SHOWN ABOVE ARE ONLY APPLICABLE TO ELEVATORS WITH HYDRAULIC HOIST SYSTEMS

N.T.S.



ELEVATOR SUMP PUMP - W/ OIL / WATER SEPARATOR

CITY OF VANCOUVER
DEPARTMENT OF PUBLIC WORKS
SANITARY SYSTEMS PLANNING AND DESIGN

DRAWN BY	APPROVED BY	APPROVAL DATE
BTC	FAD	01 - 2025
REVISION	APPROVED BY	APPROVAL DATE
-	-	-

SEWER
DETAIL NO.
S-4.3

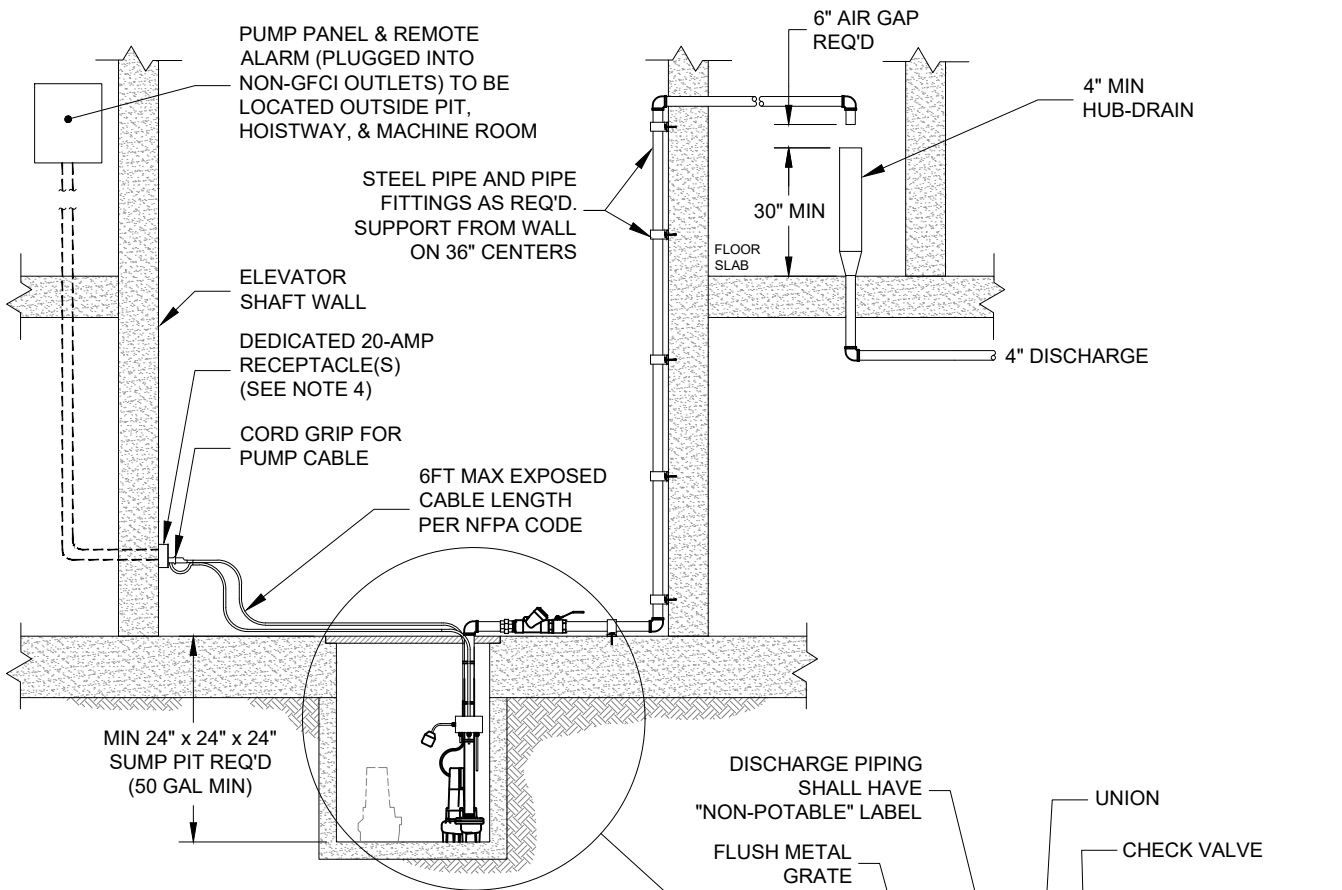

PROFILE VIEW

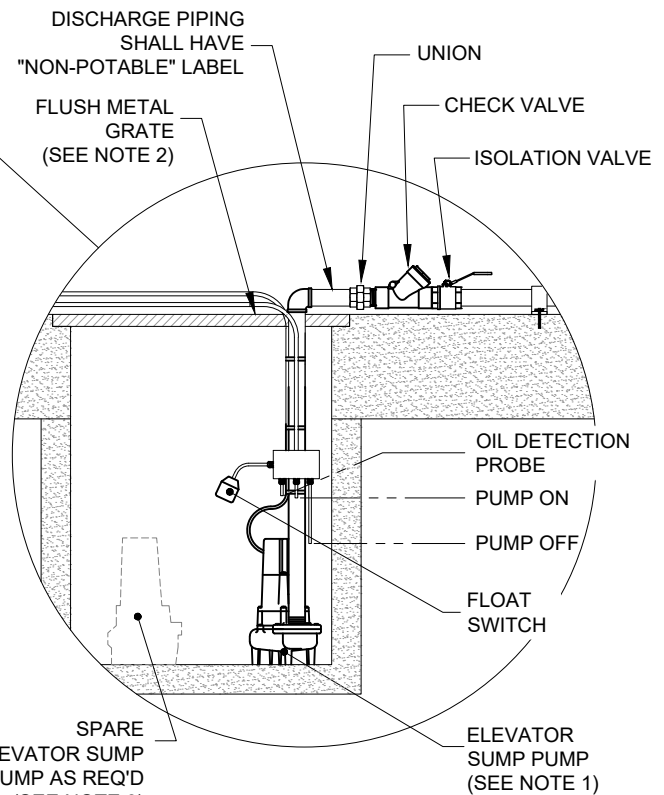

DETAIL VIEW

NOTES

1. SUMP PUMPS SHALL BE APPROVED BY THE MANUFACTURER FOR SPECIFIC USE IN ELEVATOR SHAFTS.
2. THE PUMP MUST BE LOCATED IN A SUMP HOLE WITH A GRATE COVER FLUSH WITH THE ELEVATOR PIT FLOOR CAPABLE OF WITHSTANDING 300LB WEIGHT.
3. HYDRAULIC FLUIDS & HAZARDOUS MATERIALS ARE NOT PERMITTED TO BE DRAINED TO PUBLIC SEWER.
4. DEDICATED 20AMP NON-GFCI OUTLET REQUIRED FOR ELEVATOR SUMP PUMP AND ALARM BOX.
5. SIGNAGE FOR AUDIBLE & VISUAL ALARM W/ FLOAT SWITCHES ARE REQUIRED.
6. PLUMBING INSIDE ELEVATOR SHAFT SHALL CONFORM TO ALL APPLICABLE BUILDING PLUMBING CODE.
7. ALL ELECTRICAL WORK SHALL CONFORM TO NATIONAL ELECTRIC CODE (NEC).
8. A SPARE PUMP MAY BE REQUIRED IN SOME CASES; SIZE OIL/WATER SEPARATOR TO ACCOMMODATE DUPLEX PUMP FLOWS
9. INSTALLATION TO COMPLY WITH CURRENT ELEVATOR CODE.
10. DETAILS SHOWN ABOVE ARE ONLY APPLICABLE TO ELEVATORS WITH HYDRAULIC HOIST SYSTEMS.

N.T.S.



ELEVATOR SUMP PUMP - W/ OIL SENSING ALARM

SEWER
DETAIL NO.

CITY OF VANCOUVER
DEPARTMENT OF PUBLIC WORKS
SANITARY SYSTEMS PLANNING AND DESIGN

DRAWN BY	APPROVED BY	APPROVAL DATE
BTC	FAD	01 - 2025
REVISION	APPROVED BY	APPROVAL DATE
-	-	-

S-4.4

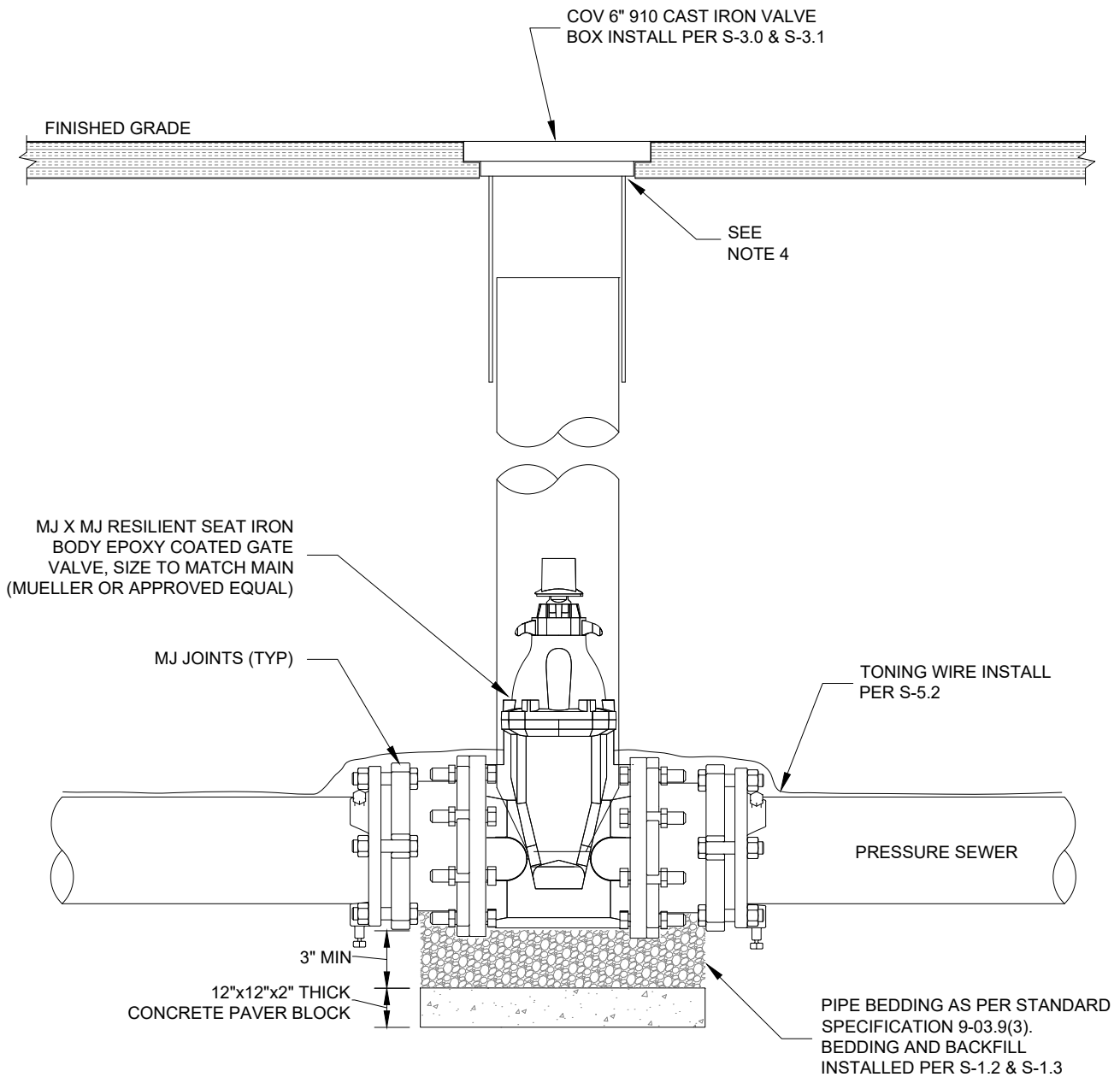

NOTES:

1. RISER PIPE SHALL BE 6" ASTM D3034 SDR 35 PVC PIPE
2. CONCRETE COLLAR SHALL BE MINIMUM STRENGTH OF 3000PSI
3. PIPE BEDDING SHALL CONFORM TO SEWER STANDARD DETAIL S-1.2.
4. CONCRETE COLLAR REQUIRED FOR VALVE BOXES PLACED IN UNPAVED AREAS. (SEE S-3.0 FOR DETAILS)

N.T.S.



PRESSURE SEWER MAIN ISOLATION VALVE

CITY OF VANCOUVER
 DEPARTMENT OF PUBLIC WORKS
 SANITARY SYSTEMS PLANNING AND DESIGN

DRAWN BY	APPROVED BY	APPROVAL DATE
BTC	SLH	01 - 2025
REVISION	APPROVED BY	APPROVAL DATE
-	-	-

SEWER
 DETAIL NO.
S-5.0

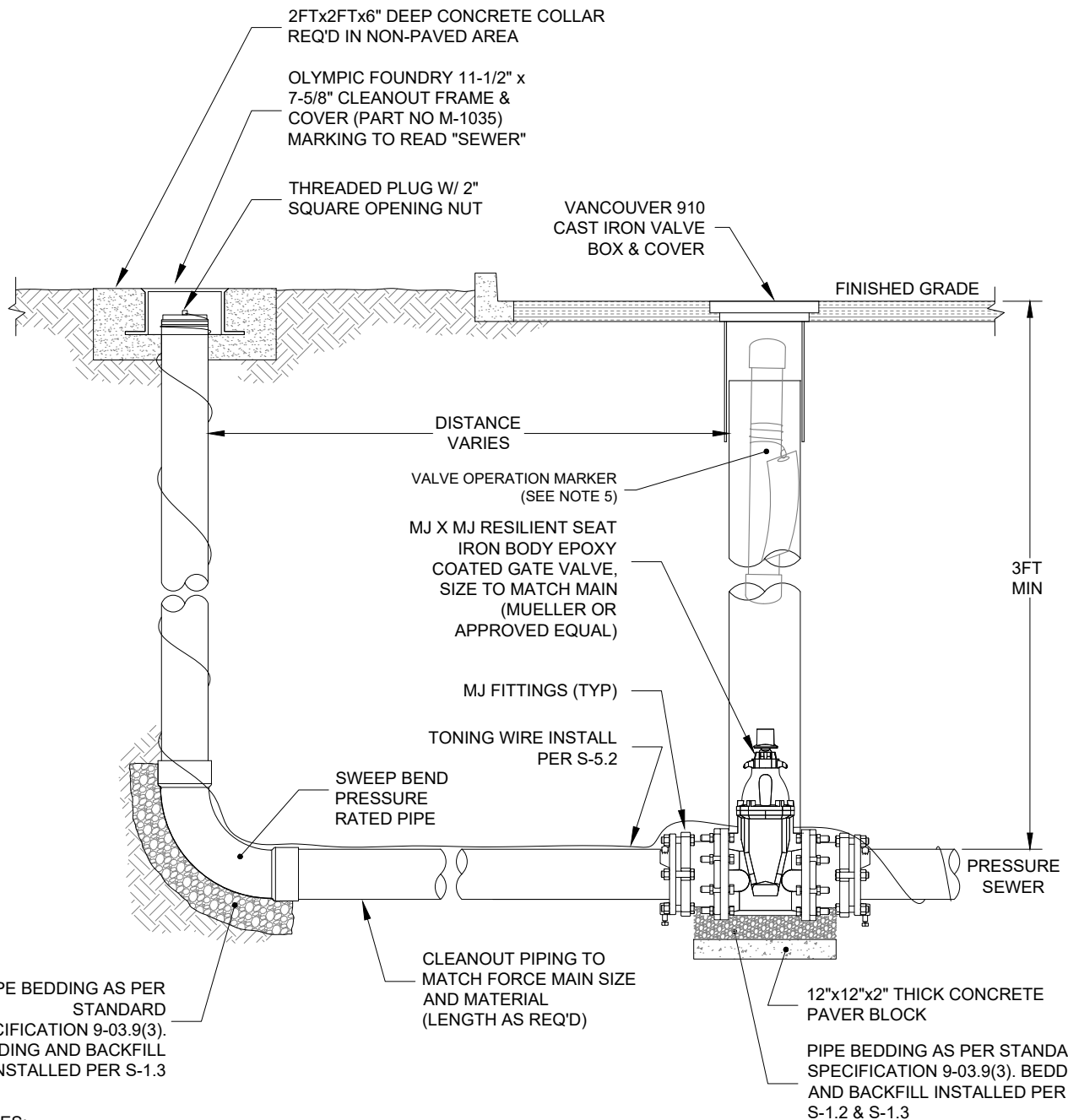

NOTES:

1. RISER PIPE FOR VALVE SHALL BE 6" ASTM D3034 SDR 35 PVC PIPE
2. CONCRETE COLLAR SHALL BE MINIMUM STRENGTH OF 3000PSI
3. PIPE BEDDING SHALL CONFORM TO SEWER STANDARD DETAIL S-1.2.
4. CONCRETE COLLAR REQUIRED FOR VALVE BOXES PLACED IN UNPAVED AREAS. (SEE S-3.0 FOR DETAILS)
5. CITY TO PROVIDE VALVE OPERATION MARKERS THAT SHALL BE PLACED IN VALVE CAN W/ TAG THAT READS; **VALVE TO BE OPERATED ONLY BY CITY OPERATIONS**
360-487-8177

N.T.S.



STANDARD PRESSURE SEWER CLEANOUT

CITY OF VANCOUVER
DEPARTMENT OF PUBLIC WORKS
SANITARY SYSTEMS PLANNING AND DESIGN

DRAWN BY	APPROVED BY	APPROVAL DATE
BTC	SLH	01 - 2025
REVISION	APPROVED BY	APPROVAL DATE
-	-	-

SEWER
DETAIL NO.
S-5.1

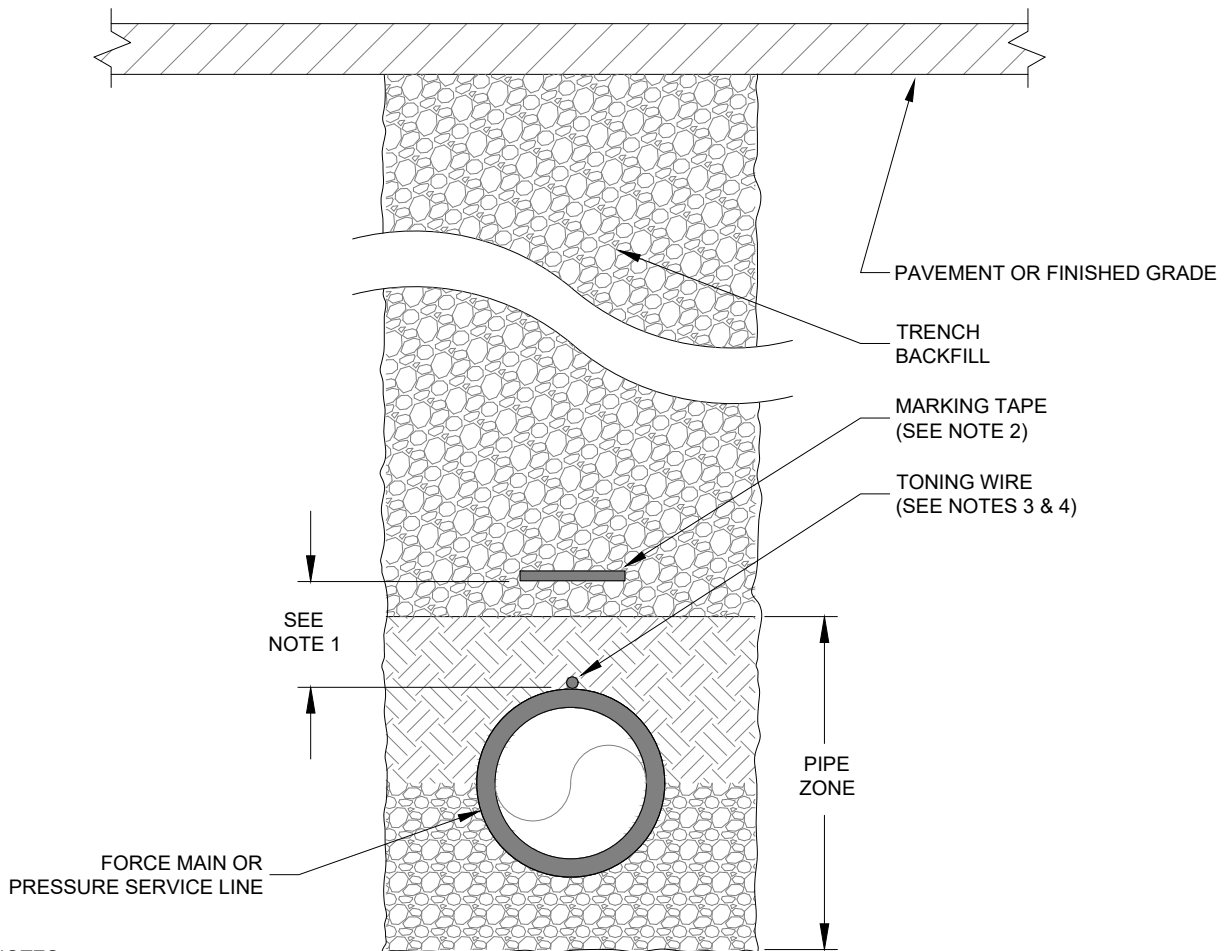

NOTES:

1. MARKING TAPE TO BE LOCATED EIGHTEEN (18) INCHES ABOVE A FORCE MAIN AND TWELVE (12) INCHES ABOVE A PRESSURE SERVICE LINE.
2. THE PIPE SHALL BE MARKED WITH CONTINUOUS GREEN THREE (3) INCH WIDE BY FOUR (4) MIL MINIMUM THICKNESS WARNING TAPE WITH ONE (1) INCH HIGH BLACK LETTERING EVERY THREE (3) FEET READING:
"CAUTION BURIED PRESSURE SEWER"
3. A CONTINUOUS WIRE SHALL BE ATTACHED TO THE TOP OF THE PRESSURE SERVICE LINE.
4. THE TONING WIRE SHALL BE RWU90 #10 AWG COPPER COATED STEEL WIRE, W/ 40 MIL MIN THICKNESS OF BLACK CROSS-LINKED POLYETHYLENE INSULATION MANUFACTURED FOR DIRECT BURIAL APPLICATIONS.
5. THE TONING WIRE SHALL BEGIN AT THE VALVE VAULT TEST STATION W/ A MINIMUM OF ONE (1) FOOT COIL OF WIRE AND END AT THE TEST STATION AT THE DISCHARGE MANHOLE.
6. THE TONING WIRE SHALL BE TESTED FOR CONTINUITY PRIOR TO ACCEPTANCE, NO SPLICES ARE ALLOWED BETWEEN TEST STATIONS.
7. THE TONING WIRE SHALL BE LAID FLAT AND SECURELY AFFIXED TO THE TOP OF THE FORCE MAIN AT 6FT INTERVALS.

N.T.S.



TONING WIRE AND MARKING TAPE

CITY OF VANCOUVER
DEPARTMENT OF PUBLIC WORKS
SANITARY SYSTEMS PLANNING AND DESIGN

DRAWN BY	APPROVED BY	APPROVAL DATE
BTC	SLH	01 - 2025
REVISION	APPROVED BY	APPROVAL DATE
-	-	-

SEWER
DETAIL NO.
S-5.2

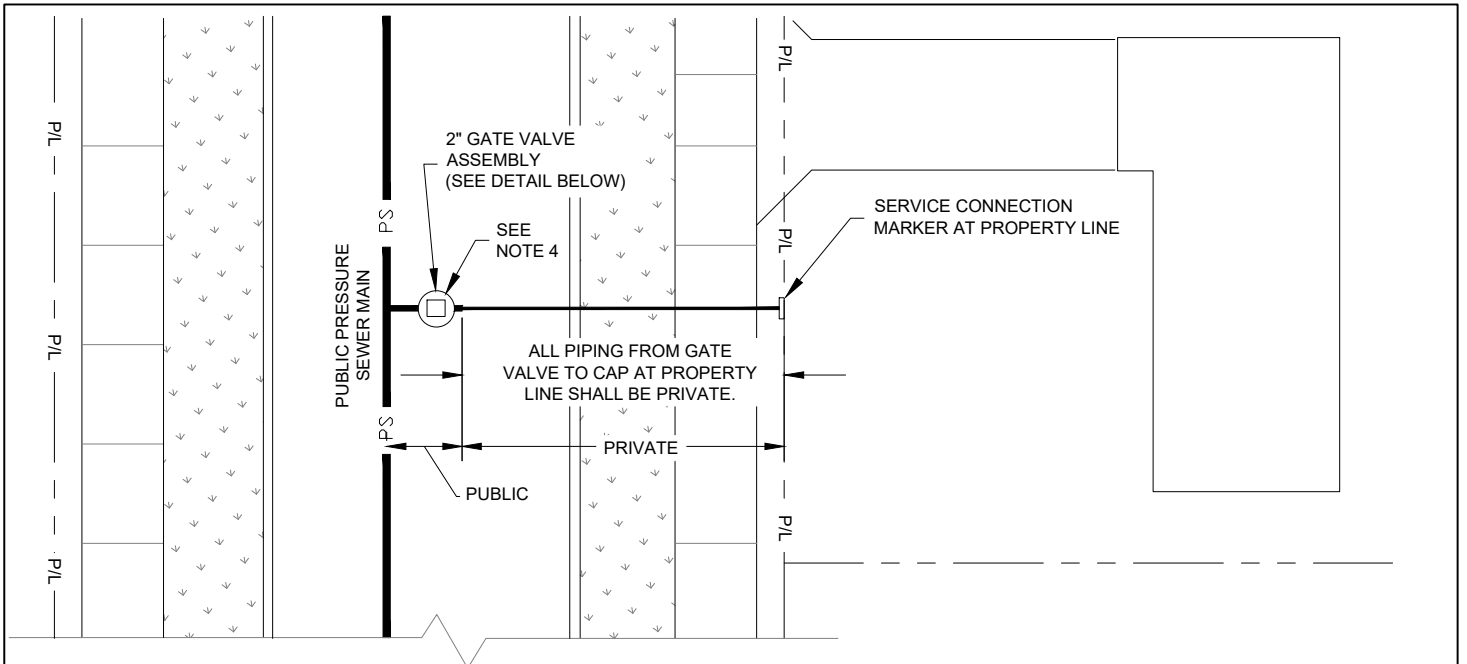

PLAN VIEW

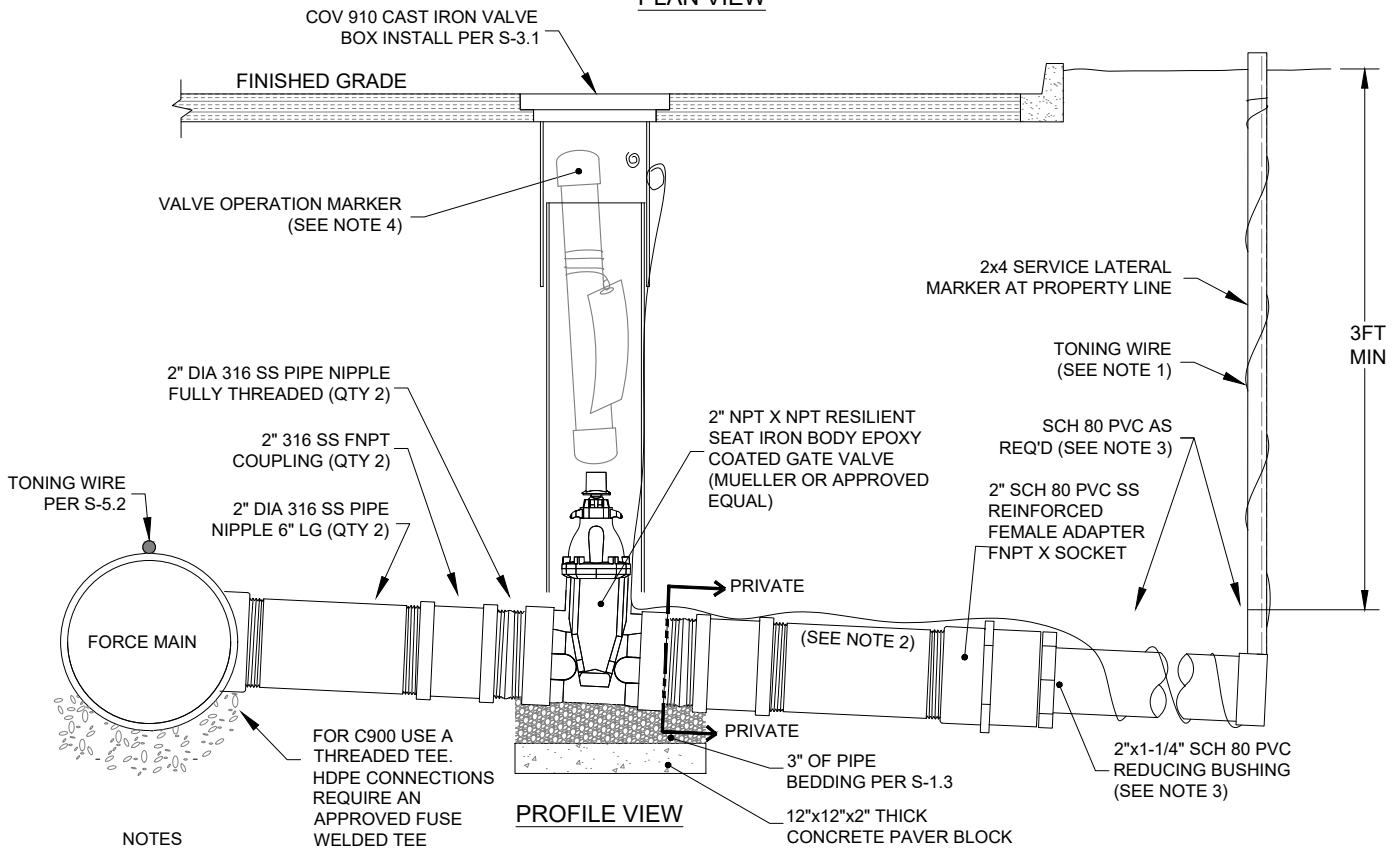

PROFILE VIEW

NOTES

1. MAINLINE & INDIVIDUAL HOUSE TONING WIRE SHALL BE ONE PIECE, NO SPLICES.
2. MAINTAIN A POSITIVE SLOPE FROM PROPERTY LINE TO PRESSURE VALVE ASSEMBLY CONNECTION.
3. RESIDENTIAL IS 1-1/4" DIA; COMMERCIAL IS 2" DIA
4. VALVE SHALL REMAIN CLOSED UNTIL ONSITE PUMP IS CONNECTED, CONTACT COV OPERATIONS 360-487-8177 TO OPEN VALVE DURING STARTUP.
5. CITY TO PROVIDE VALVE OPERATION MARKERS THAT SHALL BE PLACED IN VALVE CAN W/ TAG THAT READS;

**VALVE TO BE OPERATED ONLY BY CITY OPERATIONS
360-487-8177**

N.T.S.



STANDARD PRESSURE SERVICE CONNECTION

CITY OF VANCOUVER
DEPARTMENT OF PUBLIC WORKS
SANITARY SYSTEMS PLANNING AND DESIGN

DRAWN BY	APPROVED BY	APPROVAL DATE
BTC	SLH	01 - 2025
REVISION	APPROVED BY	APPROVAL DATE
-	-	-

SEWER
DETAIL NO.
S-5.3

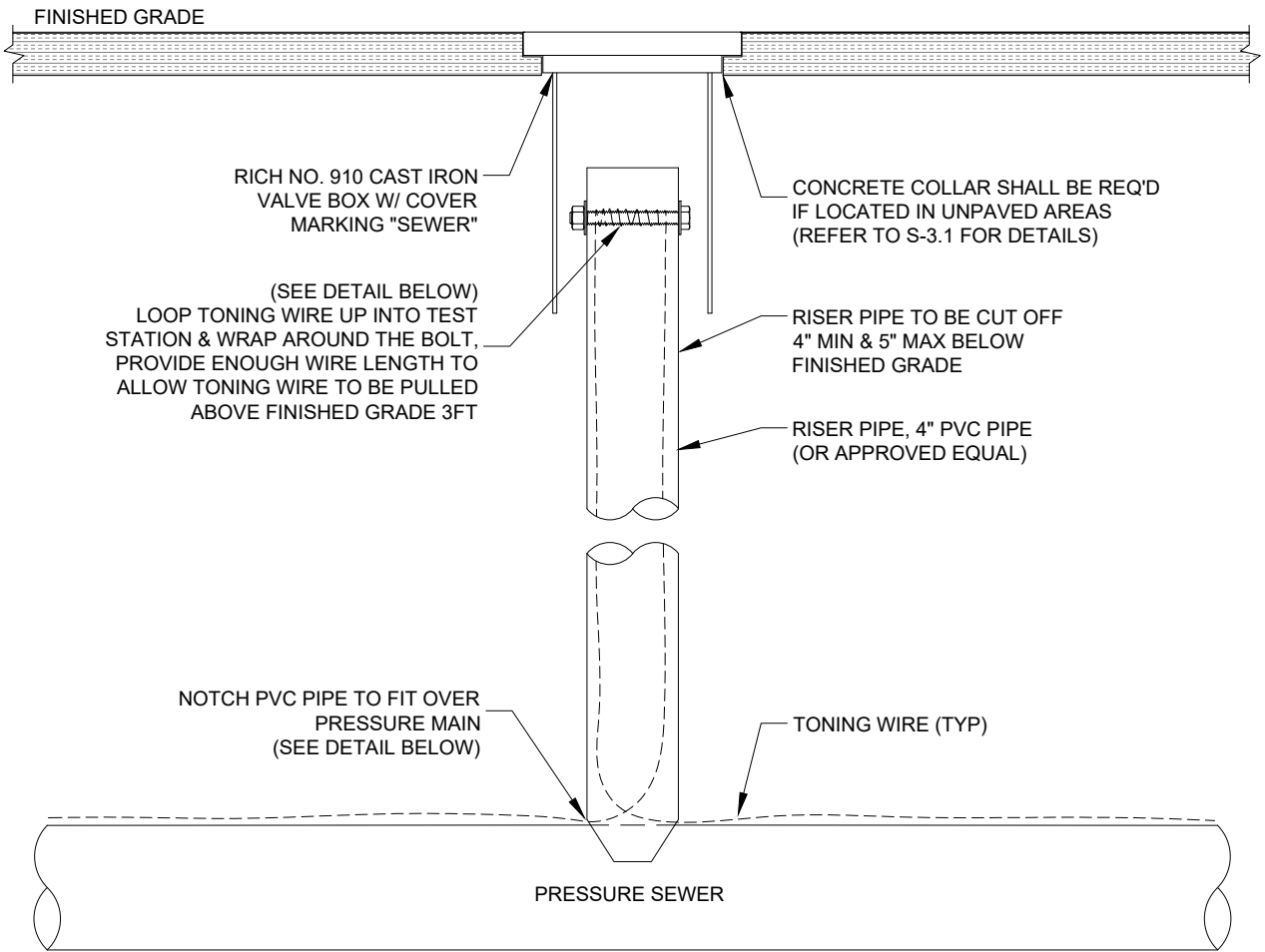

TEST STATION DETAIL

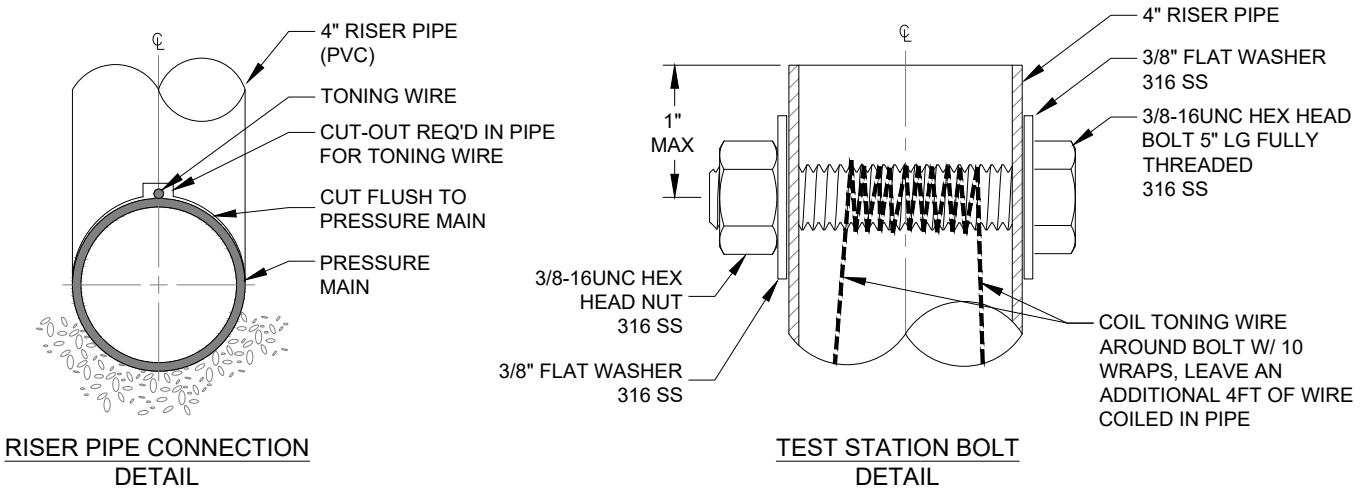

N.T.S.



STANDARD LOCATING TEST STATION

CITY OF VANCOUVER
DEPARTMENT OF PUBLIC WORKS
SANITARY SYSTEMS PLANNING AND DESIGN

DRAWN BY	APPROVED BY	APPROVAL DATE
BTC	SLH	01 - 2025
REVISION	APPROVED BY	APPROVAL DATE
-	-	-

SEWER
DETAIL NO.
S-5.4

NOTES:

1. PRESSURE CONNECTION ASSEMBLY MAY BE USED ONLY WHEN SPECIFICALLY APPROVED BY SEWER ENGINEERING. A MAXIMUM OF ONE (1) ASSEMBLY IS ALLOWED PER 48" MANHOLE.
2. ALL PIPES AND JOINTS SHALL BE CONSTRUCTED OF MATERIALS APPROVED FOR FORCE MAIN CONSTRUCTION. ALL JOINTS, PIPES, AND ANCHORS SHALL BE DESIGNED TO HANDLE THE PRESSURES AND FORCES GENERATED BY THE FLOW. REFER TO S-2.1A & 2.2A FOR STANDARD SEWER MANHOLE CONSTRUCTION REQUIREMENTS.
3. PRESSURE SEWER MAIN DISCHARGE MANHOLE SHALL BE LINED WITH RAVEN 405 EPOXY COATING (OR APPROVED EQUAL). MINIMUM THICKNESS SHALL BE 125 MILS. EQUIPMENT, PREPARATION, APPLICATION, AND CURING SHALL BE PERFORMED PER MANUFACTURERS REQUIREMENTS.
4. MANHOLE CONNECTION SHOWN FOR CASE WHERE THE PRESSURE MAIN ENTERS THE DISCHARGE MANHOLE PERPENDICULAR TO THE MANHOLE CHANNEL. CITY APPROVAL IS REQUIRED FOR FITTINGS AND ORIENTATION FOR PRESSURE MAINS ENTERING AT OTHER ANGLES.
5. EXTEND DISCHARGE PIPE SO THAT THE SPRING-LINE OF THE PRESSURE MAIN OUTLET IS NO LOWER THAN THE SPRING-LINE OF THE MANHOLE OUTLET.
6. SECURE ASSEMBLY TO WALL W/ MIN 1-1/2" 16GA 316 SS STRAPS AT EACH JOINT SECTION, USING 1-1/4"x4" LG 316 SS EXPANSION ANCHORS W/ FASTENERS OR BY INSTALLING STRAPS INTO CONCRETE WHEN FORMING BENCH FOR A NEW MANHOLE.
7. PRESSURE SEWER DISCHARGE DETAILS SHOWN BELOW APPLY TO BOTH NEW AND EXISTING MANHOLES.

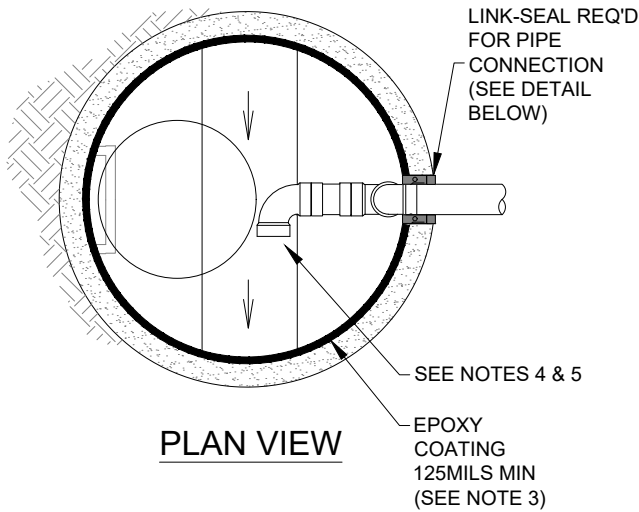

PLAN VIEW

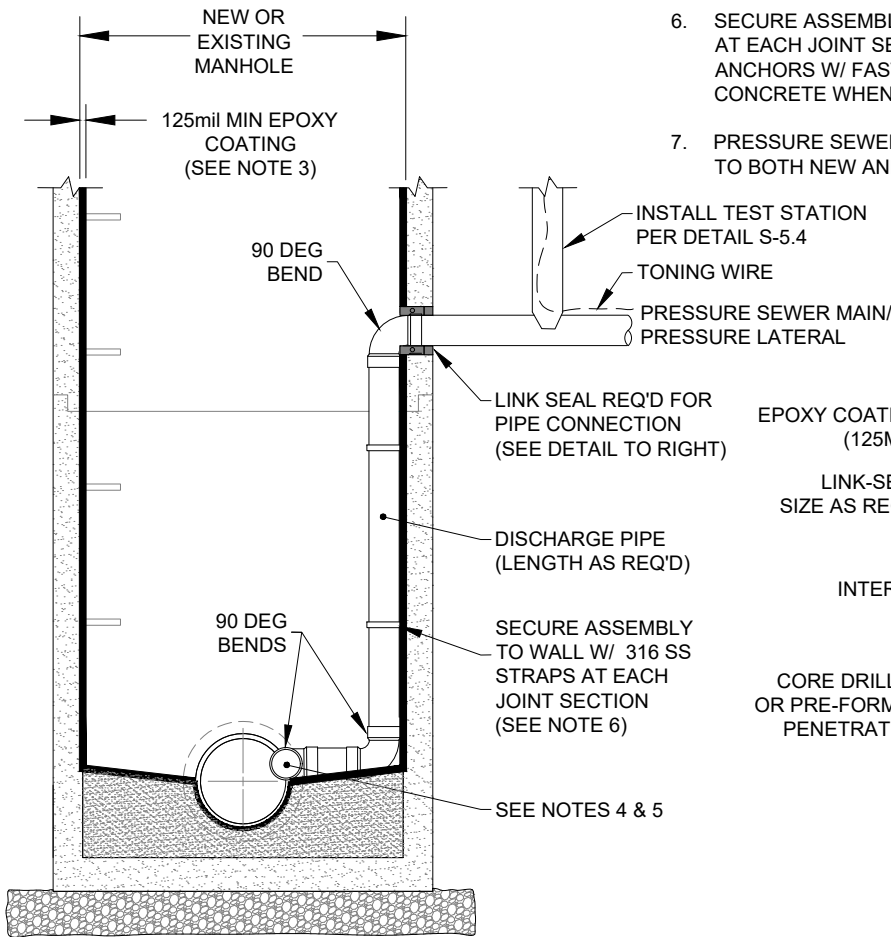

PROFILE VIEW

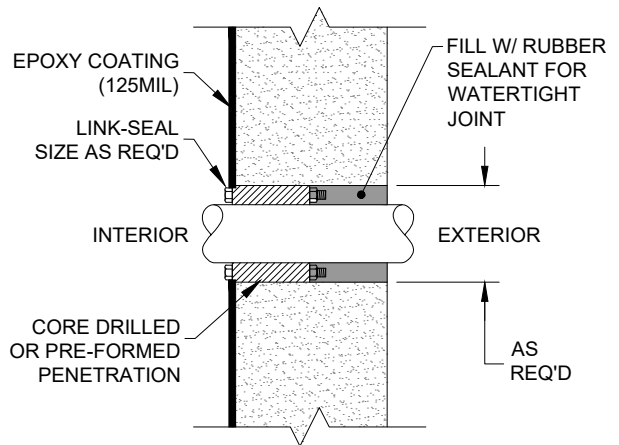

LINK-SEAL DETAIL

N.T.S.



DISCHARGE MANHOLE, FOR PRESSURE SEWERS

CITY OF VANCOUVER
DEPARTMENT OF PUBLIC WORKS
SANITARY SYSTEMS PLANNING AND DESIGN

DRAWN BY	APPROVED BY	APPROVAL DATE
BTC	SLH	01 - 2025
REVISION	APPROVED BY	APPROVAL DATE
-	-	-

SEWER
DETAIL NO.
S-5.5

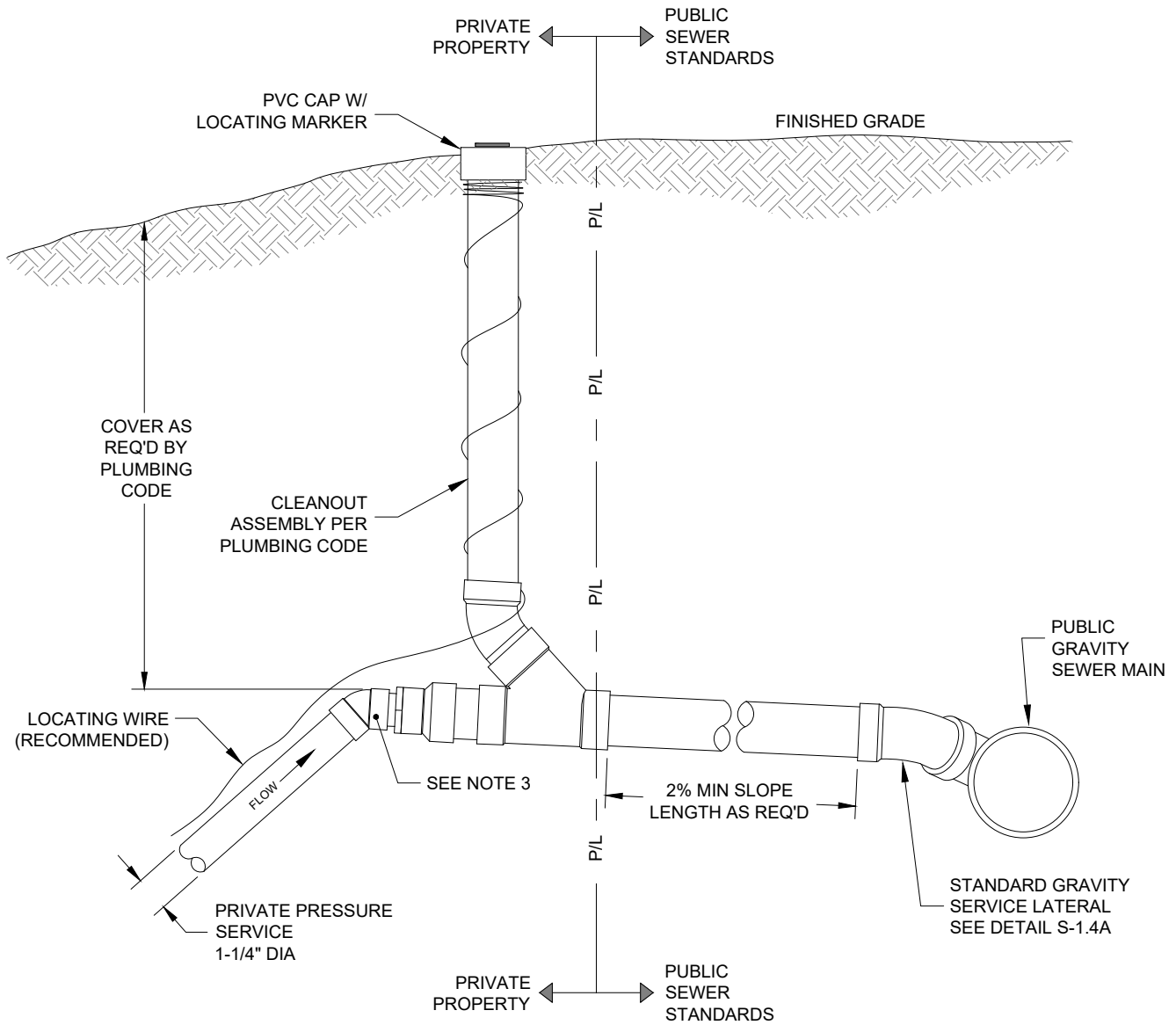

NOTES:

1. ALL ONSITE BUILDING SEWERS ARE PRIVATE AND GOVERNED BY THE BUILDING DEPARTMENTS PLUMBING CODE (UPC)
2. SHALLOW GRAVITY SERVICE LATERALS ALLOWED ON A CASE-BY-CASE BASIS AND REQUIRED CITY ENGINEERING APPROVAL
3. CONNECT THE PRIVATE ON-SITE PRESSURE PIPING TO A HIGH POINT COINCIDENT WITH THE GRAVITY LATERAL AT THE PROPERTY LINE PER UPC

N.T.S.



PRESSURE CONNECTION TO GRAVITY LATERAL

CITY OF VANCOUVER
 DEPARTMENT OF PUBLIC WORKS
 SANITARY SYSTEMS PLANNING AND DESIGN

DRAWN BY	APPROVED BY	APPROVAL DATE
BTC	SLH	01 - 2025
REVISION	APPROVED BY	APPROVAL DATE
-	-	-

SEWER
 DETAIL NO.
S-5.6

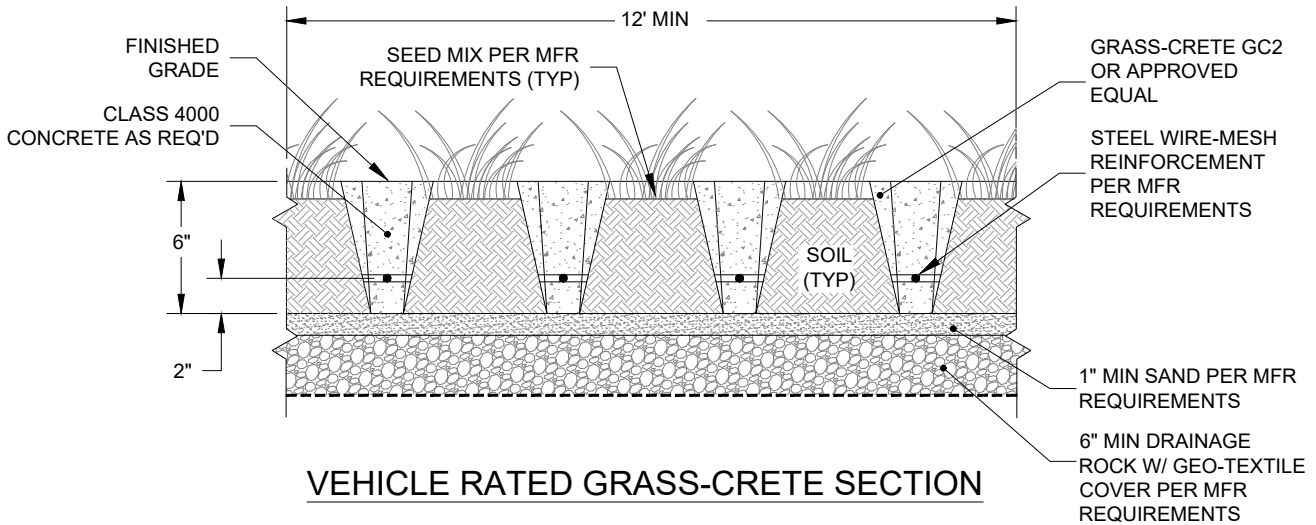
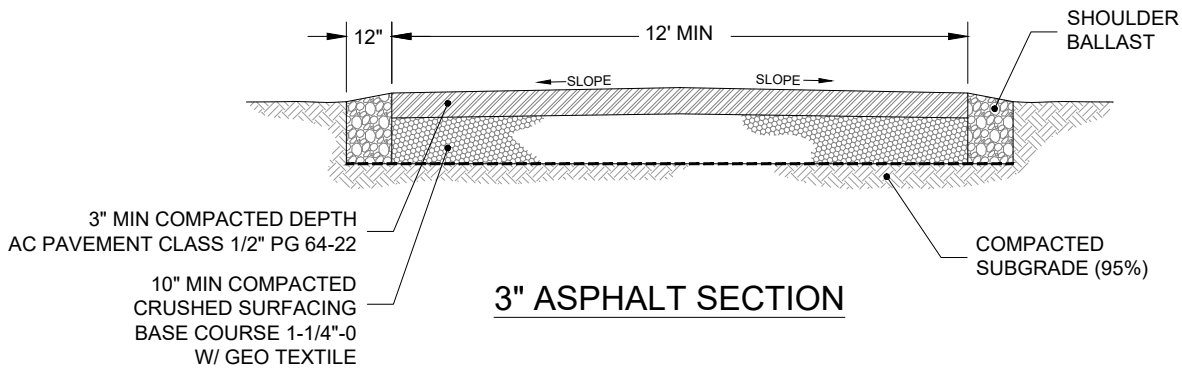
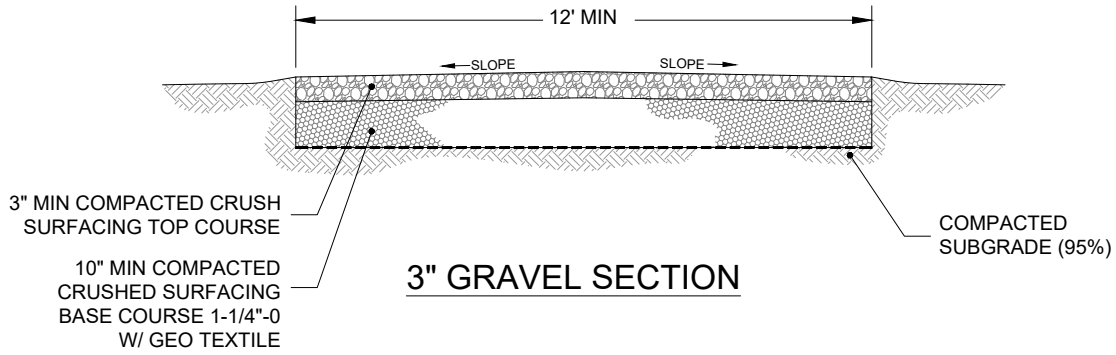

NOTES:

1. ALL DIMENSIONS SHOWN ARE MINIMUM, WIDER ACCESS ROADS MAY BE REQUIRED IN SPECIAL CASES.
2. ACCESS ROADS TO BE CENTERED OVER THE PUBLIC SEWER
3. GRASS-CRETE TYPE ACCESS ROADS REQUIRE APPROVAL FROM CITY SEWER ENGINEERING.

N.T.S.



STANDARD SEWER EASEMENT ACCESS ROADS

CITY OF VANCOUVER
DEPARTMENT OF PUBLIC WORKS
SANITARY SYSTEMS PLANNING AND DESIGN

DRAWN BY	APPROVED BY	APPROVAL DATE
BTC	SLH	01 - 2025
REVISION	APPROVED BY	APPROVAL DATE
-	-	-

SEWER
DETAIL NO.
S-6.1

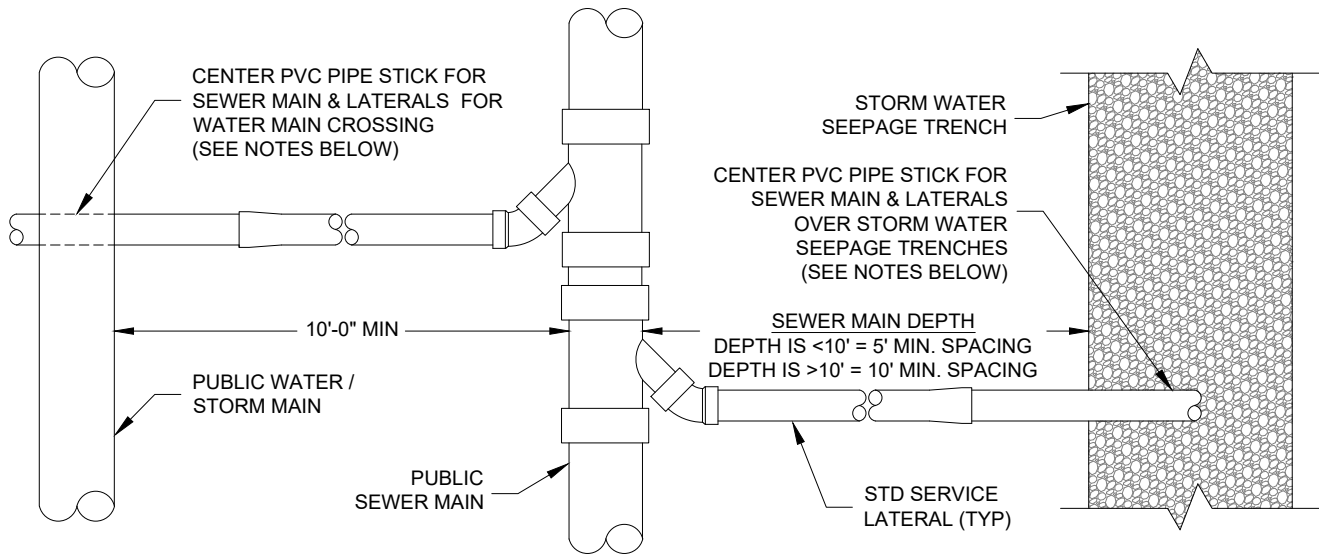

PLAN VIEW

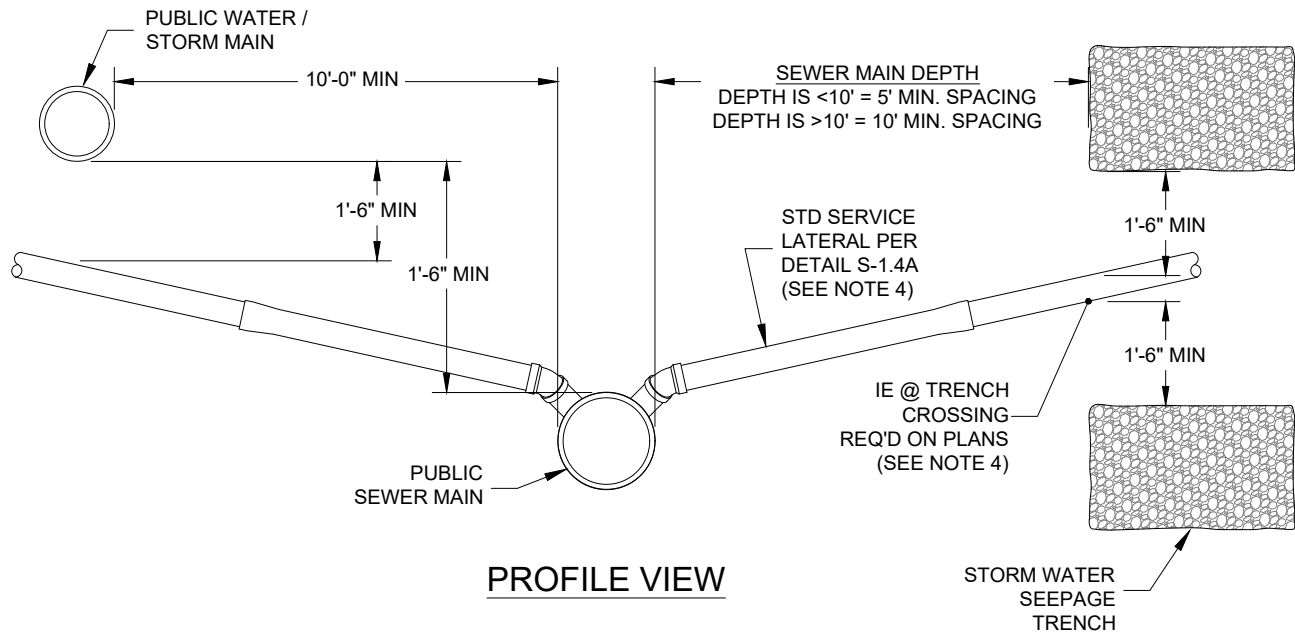

PROFILE VIEW

NOTES:

1. ANY CLEARANCE EXEMPTIONS SHALL BE SUBMITTED IN WRITING FOR CITY REVIEW AND APPROVAL.
2. ALL SEWER CROSSINGS UNDER OR OVER WATER MAINS SHALL MAXIMIZE THE JOINT SEPARATION BY USING THE LONGEST STANDARD LENGTH PIPE AVAILABLE FROM THE MANUFACTURER. PIPE STICKS SHALL BE CENTERED AT THE POINT OF CROSSING.
3. SPACING REQUIREMENTS SHOWN ABOVE SHALL ALSO APPLY TO SEWER LATERALS AND WATER SERVICES WITHIN THE RIGHT OF WAY.
4. C900 REQUIRED FOR SERVICE LATERALS AND SEWER MAINS EXTENDING OVER OR UNDER SEEPAGE TRENCH. SEE 3-5.03
5. SEPARATION REQUIREMENTS ARE FOR THE NORMAL CONDITIONS FOUND WITH SEWAGE AND WATER SYSTEMS. THESE BASIC REQUIREMENTS APPLY TO SEWERS OF 24-INCH DIAMETER OR LESS. LARGER SEWERS MAY HAVE ADDITIONAL REQUIREMENTS. MORE STRINGENT REQUIREMENTS MAY BE NECESSARY IN AREAS OF HIGH GROUND WATER, UNSTABLE SOIL CONDITIONS, ETC

N.T.S.



SEWER SEPARATION & CROSSING REQUIREMENTS

CITY OF VANCOUVER
DEPARTMENT OF PUBLIC WORKS
SANITARY SYSTEMS PLANNING AND DESIGN

DRAWN BY	APPROVED BY	APPROVAL DATE
BTC	SLH	01 - 2025
REVISION	APPROVED BY	APPROVAL DATE
-	-	-

SEWER
DETAIL NO.
S-6.2