

Appendix A

Sidewalk Completeness Maps

SIDEWALK WIDTH (STUDY SEGMENT 1)

CITY OF VANCOUVER
SAINT JOHNS SAINT JAMES
SAFETY AND
MOBILITY PROJECT

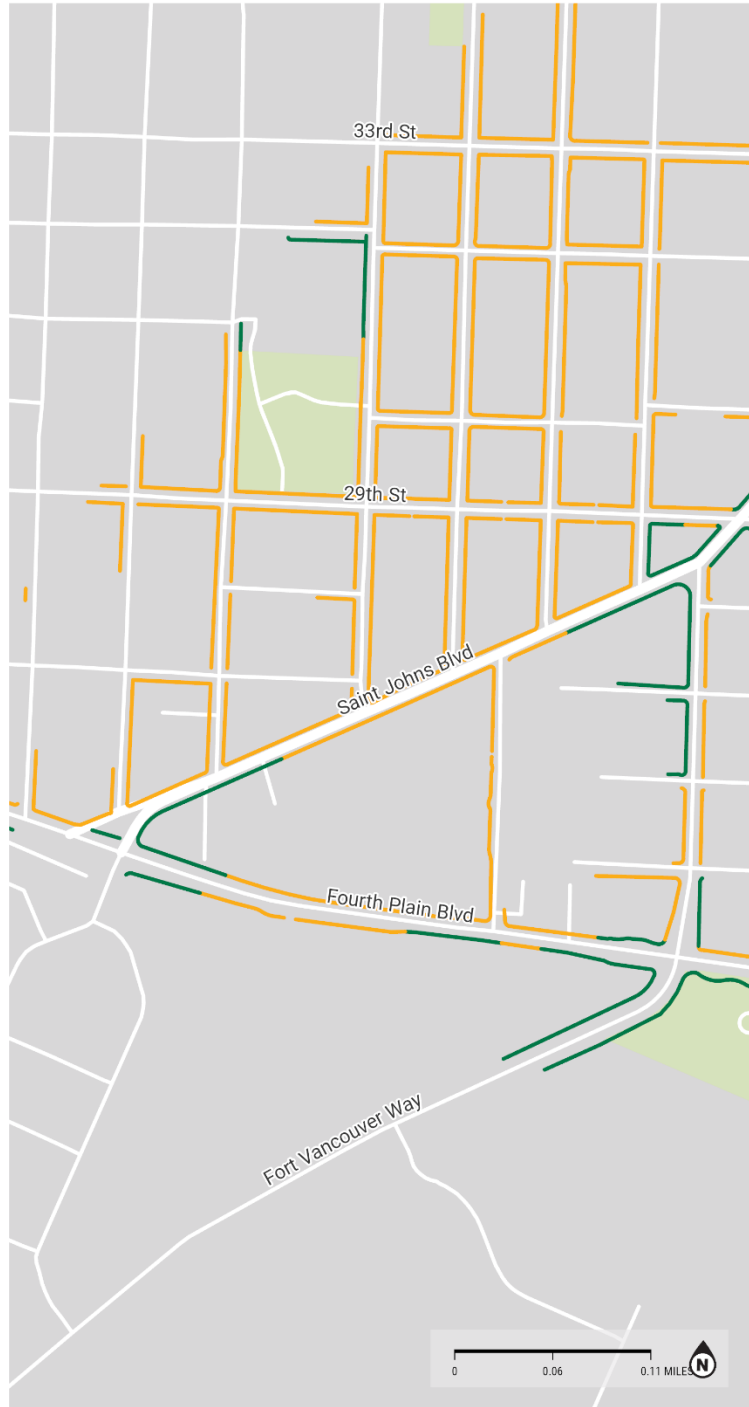

SIDEWALK WIDTH (STUDY SEGMENT 2)

CITY OF VANCOUVER
SAINT JOHNS SAINT JAMES
SAFETY AND
MOBILITY PROJECT

- SIDEWALK WIDTH
- LESS THAN 6 FEET
 - 6 FEET OR GREATER
- Background
- Railroad
 - Park
 - Vancouver City Limits

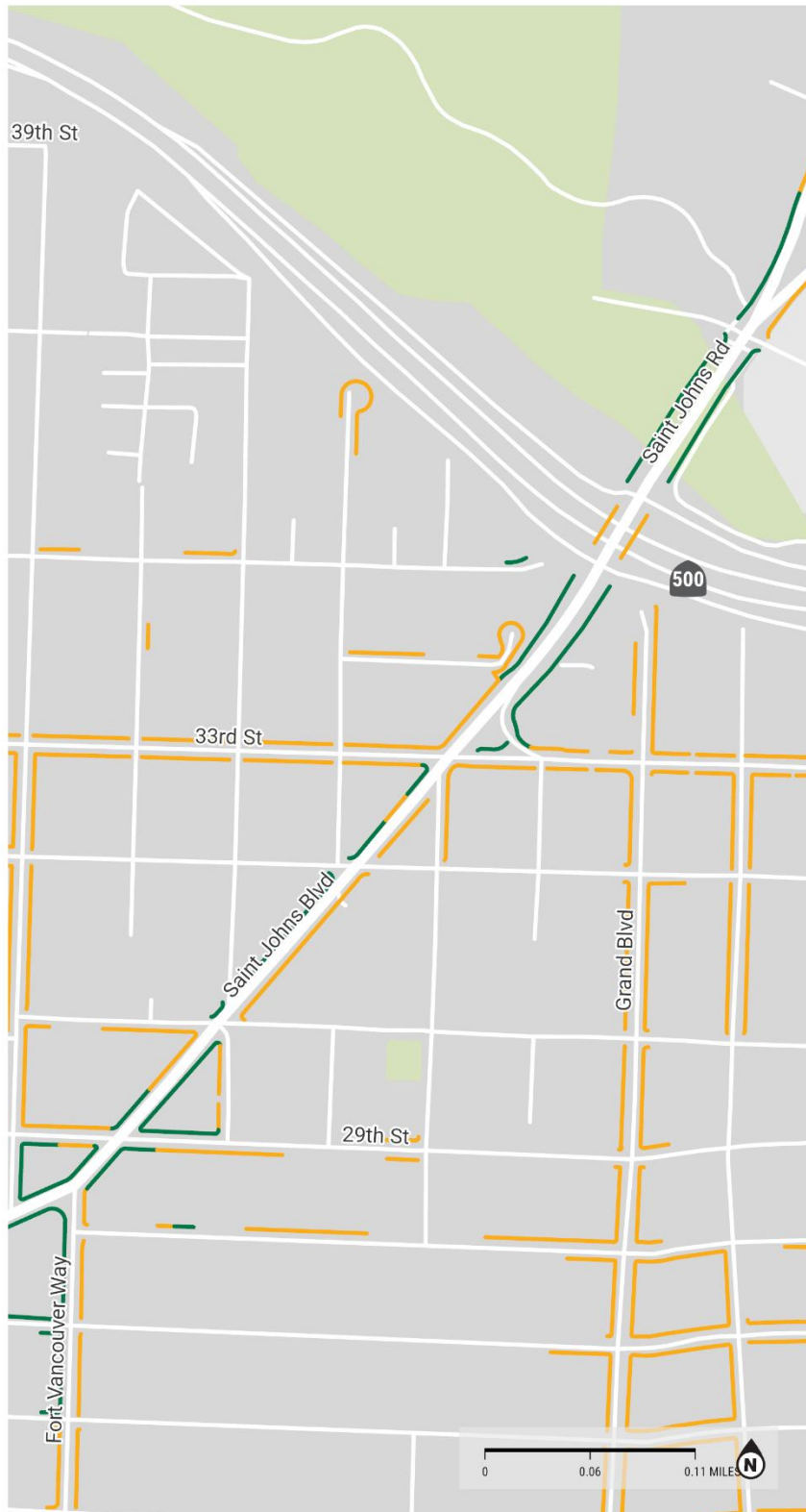

SIDEWALK WIDTH (STUDY SEGMENT 3)

CITY OF VANCOUVER
SAINT JOHNS SAINT JAMES
SAFETY AND
MOBILITY PROJECT

SIDEWALK WIDTH

- LESS THAN 6 FEET
- 6 FEET OR GREATER

Background

- Railroad
- Park
- Vancouver City Limits

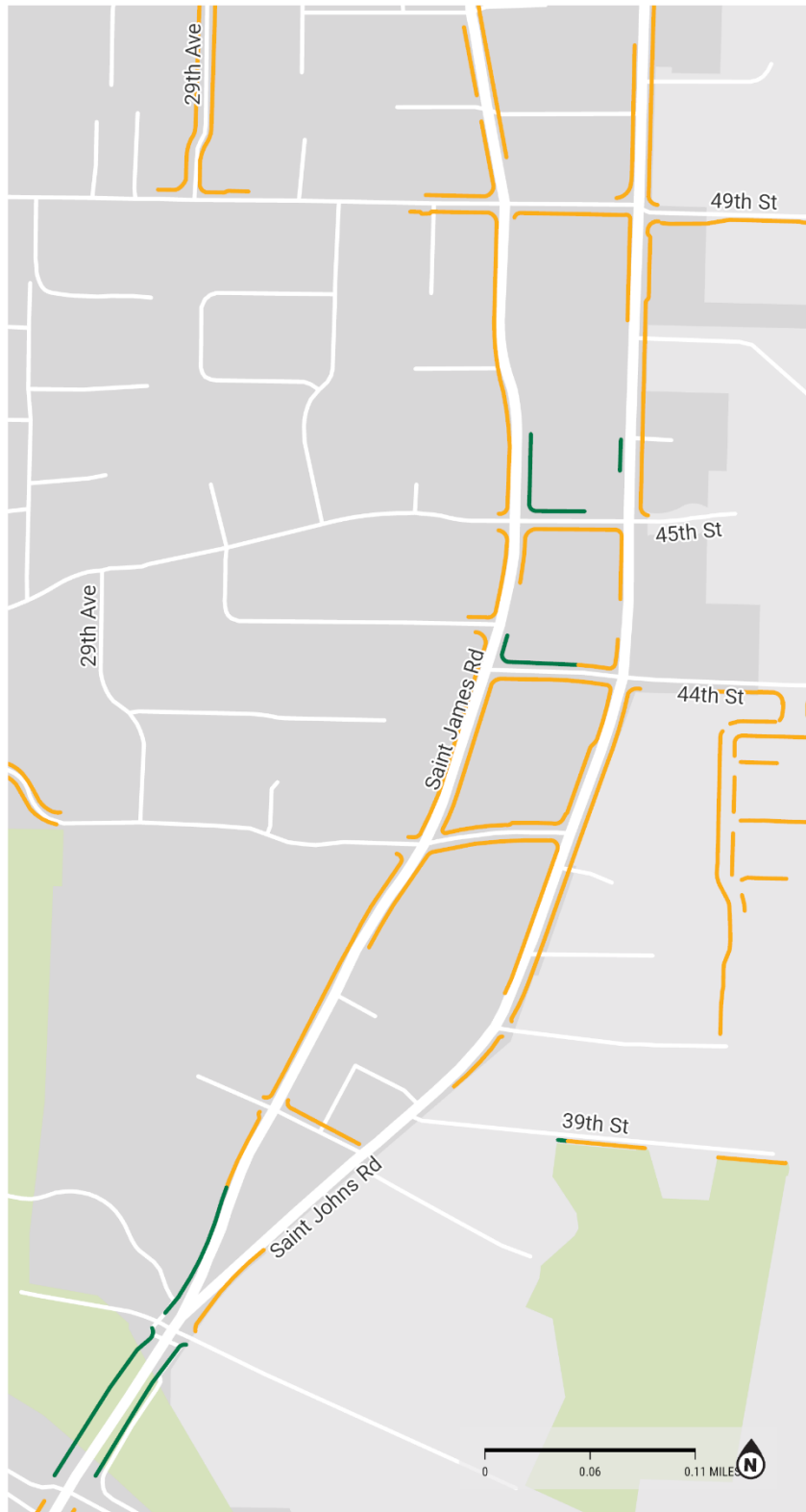

SIDEWALK WIDTH (STUDY SEGMENT 4)

CITY OF VANCOUVER
SAINT JOHNS SAINT JAMES
SAFETY AND
MOBILITY PROJECT

SIDEWALK WIDTH

- LESS THAN 6 FEET
- 6 FEET OR GREATER

Background

- Railroad
- Park
- Vancouver City Limits

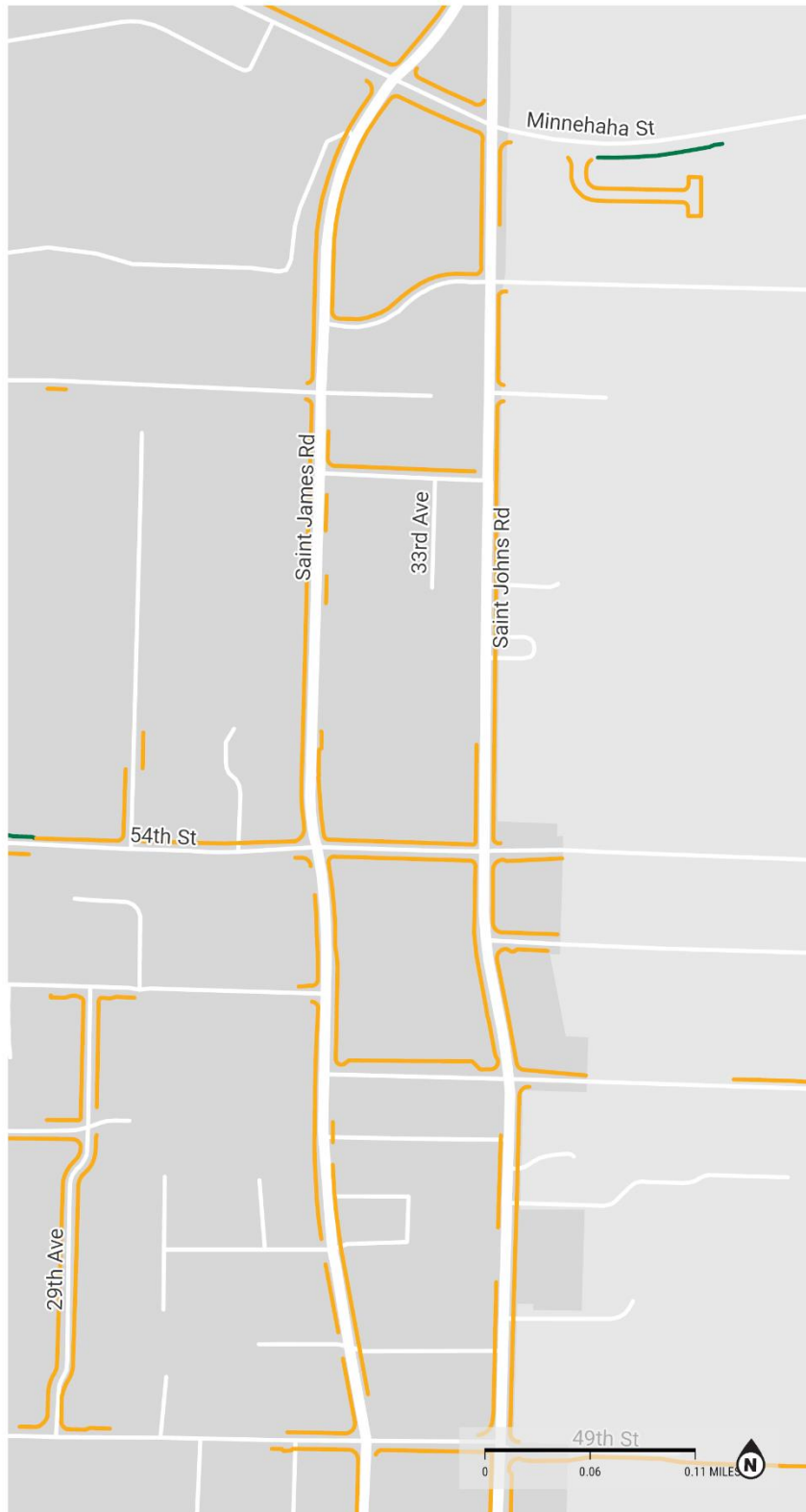

SIDEWALK WIDTH (STUDY SEGMENT 5)

CITY OF VANCOUVER
SAINT JOHNS SAINT JAMES
SAFETY AND
MOBILITY PROJECT

SIDEWALK WIDTH

- LESS THAN 6 FEET
- 6 FEET OR GREATER

Background

- Railroad
- Park
- Vancouver City Limits

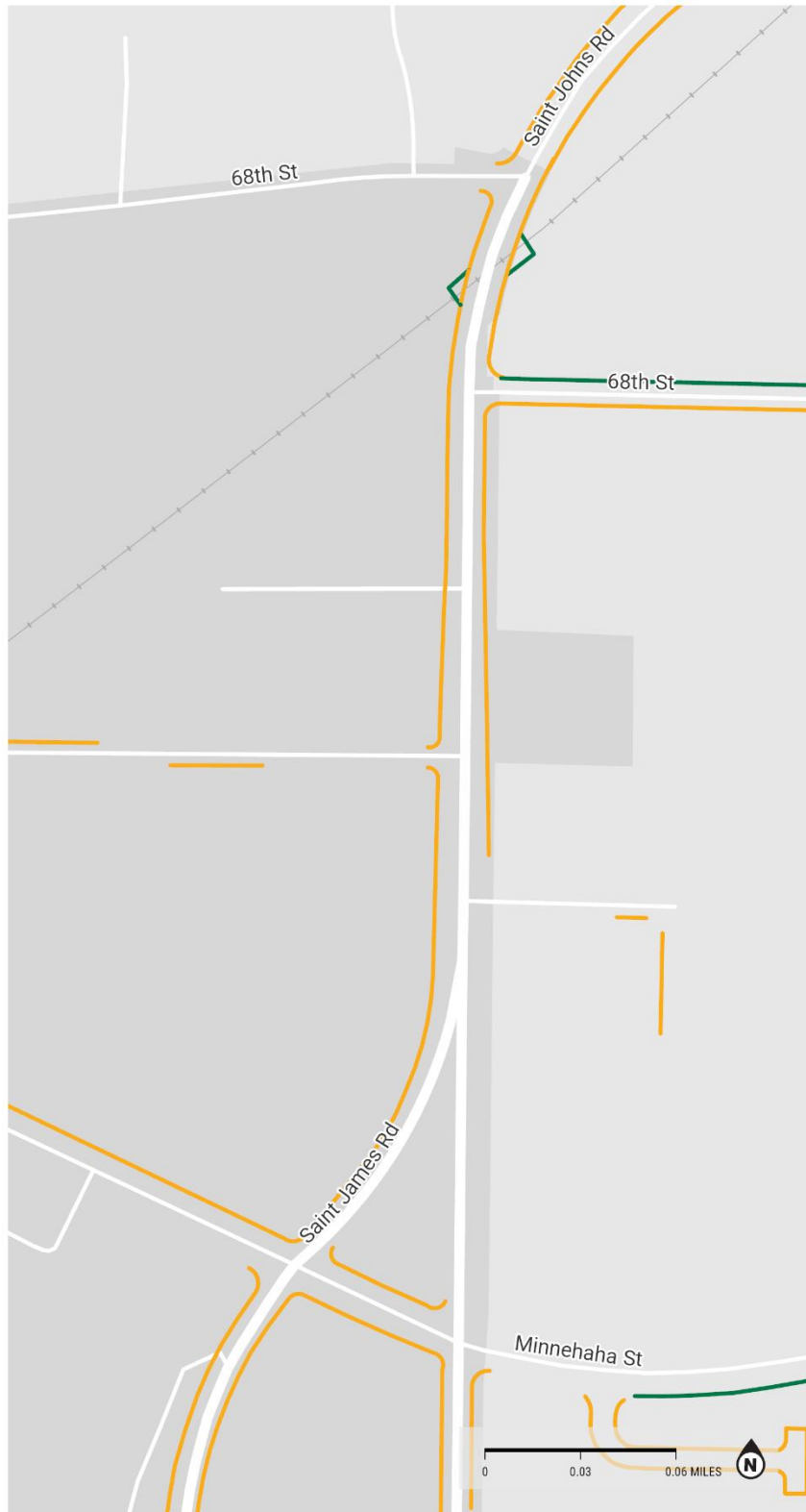



Appendix B

Parking Data Collection

30659-Vancouver Count
Parking Study

ST JOHNS BTW R ST AND V ST

		LEGAL SPACES	SATURDAY 10AM	WEEKDAY 10AM	WEEKDAY 12NOON	WEEKDAY 4PM	WEEKDAY 7PM
NORTHBOUND							
R ST	S ST		6	5	6	5	5
S ST	T ST		7	6	6	4	5
T ST	U ST		0	0	0	0	0
U ST	V ST		0	0	0	0	0
SOUTHBOUND							
V ST	U ST		0	0	0	3	1
U ST	T ST		0	0	0	0	0
T ST	S ST		2	2	2	2	1
S ST	R ST		7	3	3	5	8

ST JOHNS BTW 39TH AND 60TH

		LEGAL SPACES	SATURDAY - 10AM		WEEKDAY - 10AM		WEEKDAY - 12NOON		WEEKDAY - 4PM		WEEKDAY - 7PM	
			EAST SIDE	WEST SIDE	EAST SIDE	WEST SIDE	EAST SIDE	WEST SIDE	EAST SIDE	WEST SIDE	EAST SIDE	WEST SIDE
NORTHBOUND												
39TH	41ST		0	1	0	1	0	0	0	0	0	1
41ST	42ND		5	0	4	0	4	0	5	0	6	0
42ND	44TH		1	0	1	0	1	0	1	0	0	0
44TH	45TH		1	0	0	0	1	0	1	0	0	0
45TH	49TH		11	4	7	3	10	5	6	2	12	4
49TH	51ST		0	6	0	7	0	5	0	1	0	2
51ST	52ND		0	0	2	5	0	5	1	3	0	2
52ND	53RD		0	0	0	0	1	0	0	0	0	0
53RD	54TH		0	0	0	0	0	0	0	0	0	0
54TH	56TH		1	0	1	0	1	0	1	0	1	2
56TH	OAK HVN		0	0	0	0	0	0	0	0	0	0
OAK HVN	58TH		0	0	0	0	0	0	0	0	0	0
58TH	59TH		0	0	0	0	0	0	0	0	0	0
59TH	60TH		0	0	0	0	0	0	0	0	0	0

ST JAMES BTW MINNEHAHA AND CHERRY

		LEGAL SPACES	SATURDAY - 10AM		WEEKDAY - 10AM		WEEKDAY - 12NOON		WEEKDAY - 4PM		WEEKDAY - 7PM	
			EAST SIDE	WEST SIDE	EAST SIDE	WEST SIDE	EAST SIDE	WEST SIDE	EAST SIDE	WEST SIDE	EAST SIDE	WEST SIDE
SOUTHBOUND												
MINNEHAHA	60TH		0	8	0	6	0	6	0	8	0	9
60TH	59TH		0	0	0	0	0	0	0	1	0	1
59TH	58TH		0	0	0	0	0	0	0	1	0	0
58TH	54TH		2	5	0	4	0	3	0	3	0	3
54TH	53RD		0	0	3	0	3	0	3	0	0	0
53RD	52ND		0	0	0	0	1	0	1	0	1	0
52ND	51ST		5	6	6	5	6	5	5	5	4	7
51ST	50TH CIR		0	6	0	3	0	3	0	5	0	4
50TH CIR	49TH		0	0	0	0	0	0	0	0	0	0
49TH	45TH		0	1	0	3	0	5	0	2	0	3
45TH	44TH		0	0	0	0	0	0	0	0	0	0
44TH	42ND		0	1	0	0	0	0	0	0	0	0
42ND	CHERRY RD		0	2	0	3	0	3	0	3	0	3



Appendix C

Volume Data Collection

Table 1: Two Hour Bicycle and Pedestrian Counts

Location	AM Ped Count	PM Ped Count	Total Ped Count	AM Bike Count	PM Bike Count	Total Bike Count
<i>Fourth Plain Boulevard & St Johns Boulevard</i>	42	26	68	2	2	4
<i>St Johns Boulevard & Fort Vancouver Way</i>	16	26	42	0	0	0
<i>St Johns Boulevard & 33rd Street</i>	4	26	30	2	8	10
<i>St Johns Boulevard & SR 500 South</i>	2	16	18	8	10	18
<i>St Johns Boulevard & SR 500 North</i>	2	14	16	0	4	4
<i>St Johns Road & Petticoat Lane</i>	4	16	20	6	10	16
<i>St James Road & 42nd Street</i>	2	12	14	0	0	0
<i>St Johns Road & 44th Street</i>	10	32	42	0	0	0
<i>St James Road & 49th Street</i>	20	14	34	0	0	0
<i>St Johns Road & 49th Street</i>	20	56	76	0	0	0
<i>St James Road & 54th Street</i>	8	12	20	2	0	2
<i>St Johns Road & 54th Street</i>	6	18	24	0	0	0
<i>St Johns Road & Minnehaha Street</i>	16	14	30	2	2	4
<i>St James Road & Minnehaha Street</i>	14	22	36	0	0	0

Location: 1 ST JOHNS BLVD & 4TH PLAIN BLVD AM

Date: Thursday, December 14, 2023

Peak Hour: 07:15 AM - 08:15 AM

Peak 15-Minutes: 07:45 AM - 08:00 AM

Peak Hour

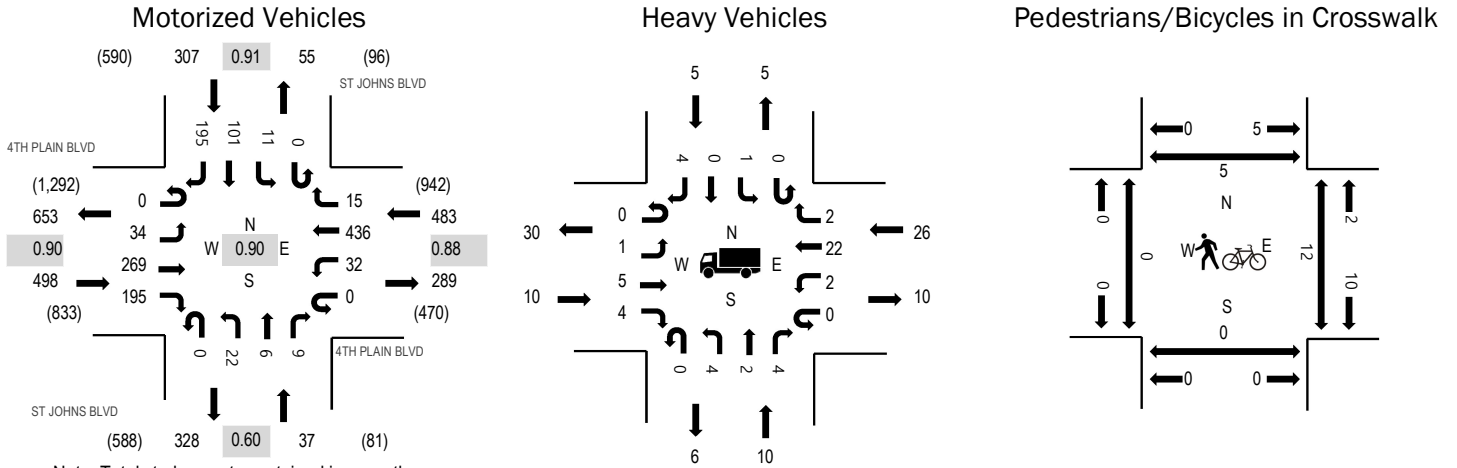

Note: Total study counts contained in parentheses.

	HV%	PHF
EB	2.0%	0.90
WB	5.4%	0.88
NB	27.0%	0.60
SB	1.6%	0.91
All	3.8%	0.90

Traffic Counts - Motorized Vehicles

Interval Start Time	4TH PLAIN BLVD Eastbound				4TH PLAIN BLVD Westbound				ST JOHNS BLVD Northbound				ST JOHNS BLVD Southbound				Total	Rolling Hour
	U-Turn	Left	Thru	Right	U-Turn	Left	Thru	Right	U-Turn	Left	Thru	Right	U-Turn	Left	Thru	Right		
6:30 AM	0	4	25	20	0	5	104	0	0	5	4	2	0	0	15	57	241	1,146
6:45 AM	0	8	42	45	0	12	99	1	0	2	4	1	0	1	24	55	294	1,244
7:00 AM	0	1	41	42	0	5	103	4	0	2	3	0	0	0	25	59	285	1,319
7:15 AM	0	6	47	60	0	13	96	3	0	3	2	3	0	0	36	57	326	1,325
7:30 AM	0	10	66	52	0	7	116	1	0	3	1	1	0	5	19	58	339	1,300
7:45 AM	0	11	79	49	0	9	124	8	0	6	2	3	0	3	28	47	369	
8:00 AM	0	7	77	34	0	3	100	3	0	10	1	2	0	3	18	33	291	
8:15 AM	0	6	62	39	0	7	119	0	0	10	6	5	0	2	21	24	301	
Count Total	0	53	439	341	0	61	861	20	0	41	23	17	0	14	186	390	2,446	
Peak Hour	0	34	269	195	0	32	436	15	0	22	6	9	0	11	101	195	1,325	

Traffic Counts - Heavy Vehicles, Bicycles on Road, and Pedestrians/Bicycles in Crosswalk

Interval Start Time	Heavy Vehicles					Interval Start Time	Bicycles on Roadway					Interval Start Time	Pedestrians/Bicycles on Crosswalk				
	EB	NB	WB	SB	Total		EB	NB	WB	SB	Total		EB	NB	WB	SB	Total
6:30 AM	2	1	5	3	11	6:30 AM	0	0	0	0	0	6:30 AM	0	0	0	1	1
6:45 AM	1	2	12	5	20	6:45 AM	0	0	0	0	0	6:45 AM	0	1	0	0	1
7:00 AM	1	0	12	3	16	7:00 AM	0	0	0	0	0	7:00 AM	0	0	0	0	0
7:15 AM	2	4	5	1	12	7:15 AM	0	0	0	0	0	7:15 AM	0	0	1	0	1
7:30 AM	2	1	9	1	13	7:30 AM	0	0	0	0	0	7:30 AM	0	0	3	2	5
7:45 AM	3	5	4	3	15	7:45 AM	0	0	0	0	0	7:45 AM	0	0	2	1	3
8:00 AM	3	0	8	0	11	8:00 AM	0	0	0	0	0	8:00 AM	0	0	6	2	8
8:15 AM	8	3	11	3	25	8:15 AM	0	0	0	0	0	8:15 AM	0	0	3	0	3
Count Total	22	16	66	19	123	Count Total	0	0	0	0	0	Count Total	0	1	15	6	22
Peak Hour	10	10	26	5	51	Peak Hour	0	0	0	0	0	Peak Hour	0	0	12	5	17

Peak Hour

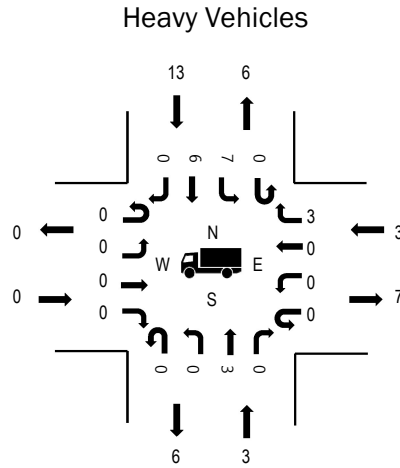
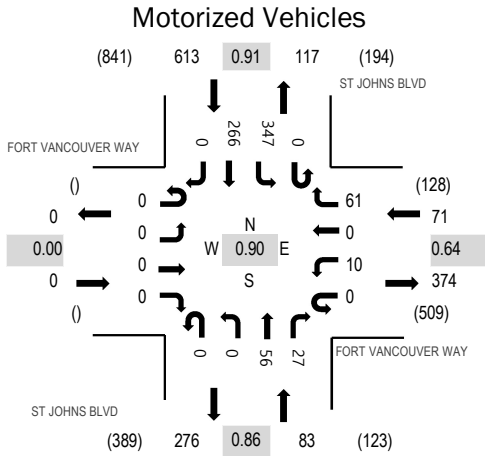

Pedestrians/Bicycles in Crosswalk

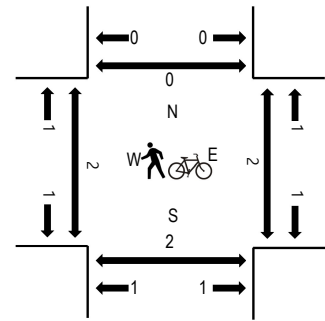

Note: Total study counts contained in parentheses.

	HV%	PHF
EB	0.0%	0.00
WB	4.2%	0.64
NB	3.6%	0.86
SB	2.1%	0.91
All	2.5%	0.90

Traffic Counts - Motorized Vehicles

Interval Start Time	FORT VANCOUVER WAY Eastbound				FORT VANCOUVER WAY Westbound				ST JOHNS BLVD Northbound				ST JOHNS BLVD Southbound				Total	Rolling Hour
	U-Turn	Left	Thru	Right	U-Turn	Left	Thru	Right	U-Turn	Left	Thru	Right	U-Turn	Left	Thru	Right		
6:30 AM																		
6:45 AM																		
7:00 AM	0	0	0	0	0	3	0	15	0	0	18	6	0	51	68	0	161	738
7:15 AM	0	0	0	0	0	1	0	9	0	0	14	5	0	64	82	0	175	767
7:30 AM	0	0	0	0	0	1	0	18	0	0	14	6	0	78	73	0	190	756
7:45 AM	0	0	0	0	0	3	0	20	0	0	14	6	0	105	64	0	212	
8:00 AM	0	0	0	0	0	5	0	14	0	0	14	10	0	100	47	0	190	
8:15 AM	0	0	0	0	0	5	0	34	0	0	10	6	0	72	37	0	164	
Count Total	0	0	0	0	0	18	0	110	0	0	84	39	0	470	371	0	1,092	
Peak Hour	0	0	0	0	0	10	0	61	0	0	56	27	0	347	266	0	767	

Traffic Counts - Heavy Vehicles, Bicycles on Road, and Pedestrians/Bicycles in Crosswalk

Interval Start Time	Heavy Vehicles					Interval Start Time	Bicycles on Roadway					Interval Start Time	Pedestrians/Bicycles on Crosswalk				
	EB	NB	WB	SB	Total		EB	NB	WB	SB	Total		EB	NB	WB	SB	Total
6:30 AM						6:30 AM						6:30 AM					
6:45 AM						6:45 AM						6:45 AM					
7:00 AM	0	2	0	2	4	7:00 AM	0	0	0	0	0	7:00 AM	0	0	0	0	0
7:15 AM	0	2	1	4	7	7:15 AM	0	0	0	1	1	7:15 AM	0	0	0	0	0
7:30 AM	0	1	0	2	3	7:30 AM	0	0	0	0	0	7:30 AM	2	2	0	0	4
7:45 AM	0	0	1	2	3	7:45 AM	0	0	0	0	0	7:45 AM	0	0	0	0	0
8:00 AM	0	0	1	5	6	8:00 AM	0	0	0	1	1	8:00 AM	0	0	2	0	2
8:15 AM	0	0	1	6	7	8:15 AM	0	0	1	0	1	8:15 AM	1	1	0	0	2
Count Total	0	5	4	21	30	Count Total	0	0	1	2	3	Count Total	3	3	2	0	8
Peak Hour	0	3	3	13	19	Peak Hour	0	0	0	2	2	Peak Hour	2	2	2	0	6

Peak Hour

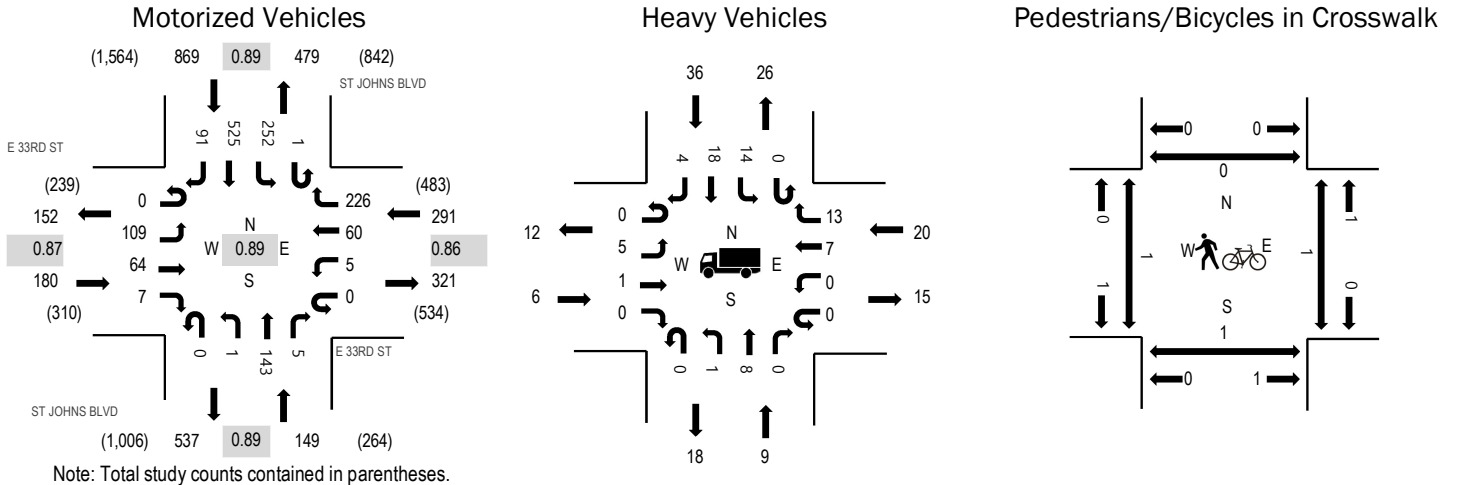

	HV%	PHF
EB	3.3%	0.87
WB	6.9%	0.86
NB	6.0%	0.89
SB	4.1%	0.89
All	4.8%	0.89

Traffic Counts - Motorized Vehicles

Interval Start Time	E 33RD ST Eastbound				E 33RD ST Westbound				ST JOHNS BLVD Northbound				ST JOHNS BLVD Southbound				Total	Rolling Hour
	U-Turn	Left	Thru	Right	U-Turn	Left	Thru	Right	U-Turn	Left	Thru	Right	U-Turn	Left	Thru	Right		
6:30 AM	0	23	1	1	0	0	6	31	0	1	24	1	0	28	93	4	213	1,132
6:45 AM	0	17	7	1	0	4	6	49	0	1	30	0	0	48	114	19	296	1,283
7:00 AM	0	24	12	2	0	2	5	48	0	1	26	1	0	48	117	18	304	1,404
7:15 AM	0	30	11	1	0	2	7	32	0	0	29	1	0	55	132	19	319	1,475
7:30 AM	0	25	12	2	0	1	13	45	0	0	33	1	0	70	142	20	364	1,489
7:45 AM	0	25	16	1	0	0	16	68	0	0	40	2	1	64	152	32	417	
8:00 AM	0	28	22	2	0	4	17	64	0	1	33	1	0	59	121	23	375	
8:15 AM	0	31	14	2	0	0	14	49	0	0	37	1	0	59	110	16	333	
Count Total	0	203	95	12	0	13	84	386	0	4	252	8	1	431	981	151	2,621	
Peak Hour	0	109	64	7	0	5	60	226	0	1	143	5	1	252	525	91	1,489	

Traffic Counts - Heavy Vehicles, Bicycles on Road, and Pedestrians/Bicycles in Crosswalk

Interval Start Time	Heavy Vehicles					Interval Start Time	Bicycles on Roadway					Interval Start Time	Pedestrians/Bicycles on Crosswalk				
	EB	NB	WB	SB	Total		EB	NB	WB	SB	Total		EB	NB	WB	SB	Total
6:30 AM	0	2	1	4	7	6:30 AM	1	0	0	0	1	6:30 AM	0	0	0	0	0
6:45 AM	0	3	3	7	13	6:45 AM	0	0	0	0	0	6:45 AM	0	0	0	0	0
7:00 AM	2	2	6	3	13	7:00 AM	0	0	0	0	0	7:00 AM	0	0	0	0	0
7:15 AM	4	4	2	5	15	7:15 AM	0	0	0	1	1	7:15 AM	0	0	0	0	0
7:30 AM	2	2	3	8	15	7:30 AM	0	1	0	1	2	7:30 AM	0	0	0	0	0
7:45 AM	1	2	8	7	18	7:45 AM	0	0	0	0	0	7:45 AM	0	0	0	0	0
8:00 AM	1	3	6	9	19	8:00 AM	0	0	0	1	1	8:00 AM	0	1	1	0	2
8:15 AM	2	2	3	12	19	8:15 AM	0	0	0	0	0	8:15 AM	1	0	0	0	1
Count Total	12	20	32	55	119	Count Total	1	1	0	3	5	Count Total	1	1	1	0	3
Peak Hour	6	9	20	36	71	Peak Hour	0	1	0	2	3	Peak Hour	1	1	1	0	3

Peak Hour

Motorized Vehicles

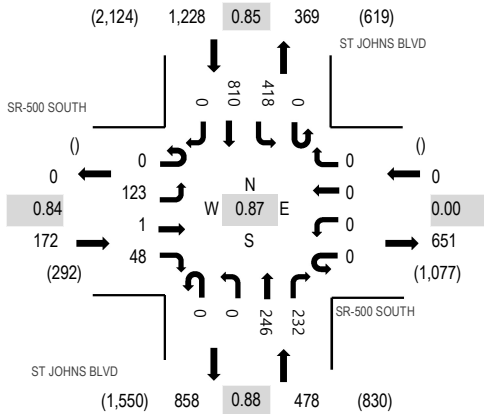

Heavy Vehicles

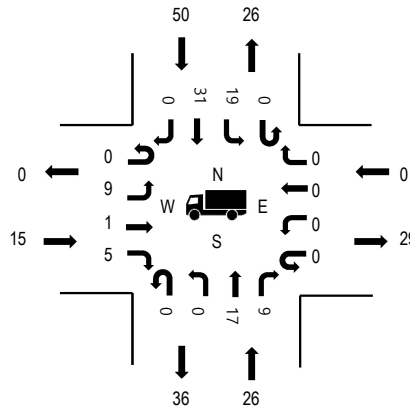

Pedestrians/Bicycles in Crosswalk

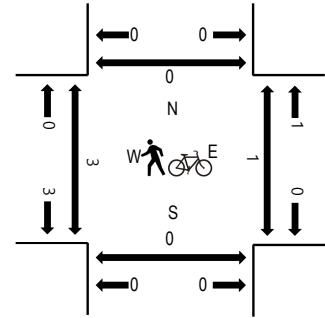

Note: Total study counts contained in parentheses.

	HV%	PHF
EB	8.7%	0.84
WB	0.0%	0.00
NB	5.4%	0.88
SB	4.1%	0.85
All	4.8%	0.87

Traffic Counts - Motorized Vehicles

Interval Start Time	SR-500 SOUTH Eastbound				SR-500 SOUTH Westbound				ST JOHNS BLVD Northbound				ST JOHNS BLVD Southbound				Total	Rolling Hour
	U-Turn	Left	Thru	Right	U-Turn	Left	Thru	Right	U-Turn	Left	Thru	Right	U-Turn	Left	Thru	Right		
6:30 AM	0	14	0	4	0	0	0	0	0	0	36	36	0	48	122	0	260	1,368
6:45 AM	0	17	1	10	0	0	0	0	0	0	46	54	0	49	164	0	341	1,572
7:00 AM	0	30	0	16	0	0	0	0	0	0	46	46	0	71	165	0	374	1,769
7:15 AM	0	19	0	9	0	0	0	0	0	0	42	46	0	75	202	0	393	1,856
7:30 AM	0	29	0	18	0	0	0	0	0	0	50	58	0	100	209	0	464	1,878
7:45 AM	0	27	0	9	0	0	0	0	0	0	74	62	0	118	248	0	538	
8:00 AM	0	22	1	15	0	0	0	0	0	0	61	64	0	107	191	0	461	
8:15 AM	0	45	0	6	0	0	0	0	0	0	61	48	0	93	162	0	415	
Count Total	0	203	2	87	0	0	0	0	0	0	416	414	0	661	1,463	0	3,246	
Peak Hour	0	123	1	48	0	0	0	0	0	0	246	232	0	418	810	0	1,878	

Traffic Counts - Heavy Vehicles, Bicycles on Road, and Pedestrians/Bicycles in Crosswalk

Interval Start Time	Heavy Vehicles					Interval Start Time	Bicycles on Roadway					Interval Start Time	Pedestrians/Bicycles on Crosswalk				
	EB	NB	WB	SB	Total		EB	NB	WB	SB	Total		EB	NB	WB	SB	Total
6:30 AM	0	3	0	5	8	6:30 AM	0	0	0	0	0	6:30 AM	0	0	0	0	0
6:45 AM	2	5	0	7	14	6:45 AM	0	0	0	0	0	6:45 AM	0	0	0	0	0
7:00 AM	4	5	0	5	14	7:00 AM	0	0	0	0	0	7:00 AM	0	0	0	0	0
7:15 AM	0	7	0	9	16	7:15 AM	0	0	0	1	1	7:15 AM	1	0	0	0	1
7:30 AM	6	6	0	5	17	7:30 AM	0	1	0	1	2	7:30 AM	1	0	1	0	2
7:45 AM	2	8	0	11	21	7:45 AM	0	0	0	0	0	7:45 AM	0	0	0	0	0
8:00 AM	3	6	0	13	22	8:00 AM	0	0	0	1	1	8:00 AM	1	0	0	0	1
8:15 AM	4	6	0	21	31	8:15 AM	0	0	0	0	0	8:15 AM	1	0	0	0	1
Count Total	21	46	0	76	143	Count Total	0	1	0	3	4	Count Total	4	0	1	0	5
Peak Hour	15	26	0	50	91	Peak Hour	0	1	0	2	3	Peak Hour	3	0	1	0	4

Location: 5 ST JOHNS BLVD & SR-500 NORTH AM

Date: Thursday, December 14, 2023

Peak Hour: 07:30 AM - 08:30 AM

Peak 15-Minutes: 07:45 AM - 08:00 AM

Peak Hour

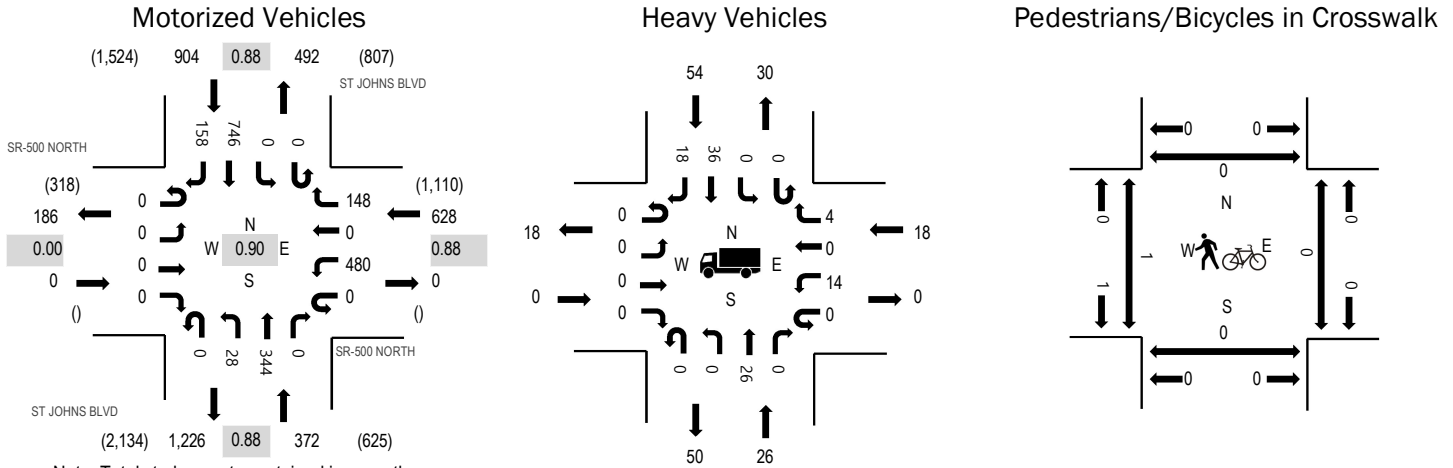

Note: Total study counts contained in parentheses.

	HV%	PHF
EB	0.0%	0.00
WB	2.9%	0.88
NB	7.0%	0.88
SB	6.0%	0.88
All	5.1%	0.90

Traffic Counts - Motorized Vehicles

Interval Start Time	SR-500 NORTH Eastbound				SR-500 NORTH Westbound				ST JOHNS BLVD Northbound				ST JOHNS BLVD Southbound				Total	Rolling Hour
	U-Turn	Left	Thru	Right	U-Turn	Left	Thru	Right	U-Turn	Left	Thru	Right	U-Turn	Left	Thru	Right		
6:30 AM	0	0	0	0	0	77	1	17	0	4	46	0	0	0	98	32	275	1,355
6:45 AM	0	0	0	0	0	106	0	26	0	3	61	0	0	0	112	26	334	1,541
7:00 AM	0	0	0	0	0	90	0	15	0	8	68	0	0	0	147	28	356	1,738
7:15 AM	0	0	0	0	0	129	0	21	0	2	61	0	0	0	149	28	390	1,848
7:30 AM	0	0	0	0	0	149	0	34	0	5	71	0	0	0	173	29	461	1,904
7:45 AM	0	0	0	0	0	132	0	39	0	9	94	0	0	0	219	38	531	
8:00 AM	0	0	0	0	0	100	0	42	0	7	80	0	0	0	198	39	466	
8:15 AM	0	0	0	0	0	99	0	33	0	7	99	0	0	0	156	52	446	
Count Total	0	0	0	0	0	882	1	227	0	45	580	0	0	0	1,252	272	3,259	
Peak Hour	0	0	0	0	0	480	0	148	0	28	344	0	0	0	746	158	1,904	

Traffic Counts - Heavy Vehicles, Bicycles on Road, and Pedestrians/Bicycles in Crosswalk

Interval Start Time	Heavy Vehicles					Interval Start Time	Bicycles on Roadway					Interval Start Time	Pedestrians/Bicycles on Crosswalk				
	EB	NB	WB	SB	Total		EB	NB	WB	SB	Total		EB	NB	WB	SB	Total
6:30 AM	0	2	2	4	8	6:30 AM	0	0	0	0	0	6:30 AM	0	0	0	0	0
6:45 AM	0	4	4	7	15	6:45 AM	0	0	0	0	0	6:45 AM	0	0	0	0	0
7:00 AM	0	7	6	5	18	7:00 AM	0	0	0	0	0	7:00 AM	0	0	0	0	0
7:15 AM	0	6	1	12	19	7:15 AM	0	0	0	1	1	7:15 AM	0	0	0	0	0
7:30 AM	0	5	6	6	17	7:30 AM	0	1	0	1	2	7:30 AM	0	0	0	0	0
7:45 AM	0	9	4	10	23	7:45 AM	0	0	0	0	0	7:45 AM	0	0	0	0	0
8:00 AM	0	5	5	13	23	8:00 AM	0	0	0	1	1	8:00 AM	0	0	0	0	0
8:15 AM	0	7	3	25	35	8:15 AM	0	0	0	0	0	8:15 AM	1	0	0	0	1
Count Total	0	45	31	82	158	Count Total	0	1	0	3	4	Count Total	1	0	0	0	1
Peak Hour	0	26	18	54	98	Peak Hour	0	1	0	2	3	Peak Hour	1	0	0	0	1

Peak Hour

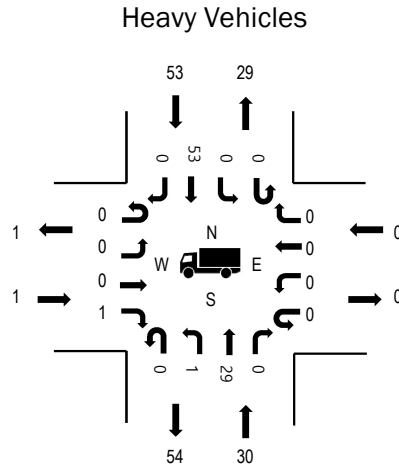
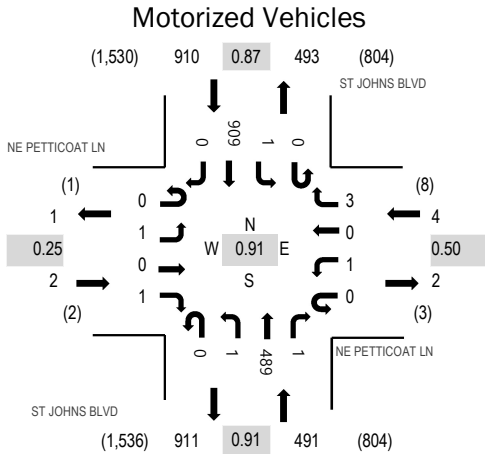

Pedestrians/Bicycles in Crosswalk

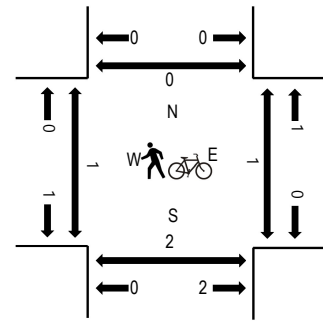

Note: Total study counts contained in parentheses.

	HV%	PHF
EB	50.0%	0.25
WB	0.0%	0.50
NB	6.1%	0.91
SB	5.8%	0.87
All	6.0%	0.91

Traffic Counts - Motorized Vehicles

Interval Start Time	NE PETTICOAT LN Eastbound				NE PETTICOAT LN Westbound				ST JOHNS BLVD Northbound				ST JOHNS BLVD Southbound				Total	Rolling Hour
	U-Turn	Left	Thru	Right	U-Turn	Left	Thru	Right	U-Turn	Left	Thru	Right	U-Turn	Left	Thru	Right		
6:30 AM	0	0	0	0	0	0	0	0	0	0	56	0	0	0	137	0	193	937
6:45 AM	0	0	0	0	0	1	0	1	2	0	90	0	0	0	144	0	238	1,061
7:00 AM	0	0	0	0	0	2	0	0	0	0	80	0	0	0	168	0	250	1,210
7:15 AM	0	0	0	0	0	0	0	0	0	0	84	1	0	0	171	0	256	1,310
7:30 AM	0	1	0	1	0	0	0	0	0	1	110	0	0	0	204	0	317	1,407
7:45 AM	0	0	0	0	0	0	0	1	0	0	125	0	0	0	261	0	387	
8:00 AM	0	0	0	0	0	0	0	1	0	0	120	0	0	0	229	0	350	
8:15 AM	0	0	0	0	0	1	0	1	0	0	134	1	0	1	215	0	353	
Count Total	0	1	0	1	0	4	0	4	2	1	799	2	0	1	1,529	0	2,344	
Peak Hour	0	1	0	1	0	1	0	3	0	1	489	1	0	1	909	0	1,407	

Traffic Counts - Heavy Vehicles, Bicycles on Road, and Pedestrians/Bicycles in Crosswalk

Interval Start Time	Heavy Vehicles					Interval Start Time	Bicycles on Roadway					Interval Start Time	Pedestrians/Bicycles on Crosswalk				
	EB	NB	WB	SB	Total		EB	NB	WB	SB	Total		EB	NB	WB	SB	Total
6:30 AM	0	2	0	4	6	6:30 AM	0	0	0	0	0	6:30 AM	0	0	0	0	0
6:45 AM	0	5	0	7	12	6:45 AM	0	0	0	0	0	6:45 AM	0	0	1	0	1
7:00 AM	0	10	0	5	15	7:00 AM	0	0	0	0	0	7:00 AM	0	0	0	0	0
7:15 AM	0	7	0	12	19	7:15 AM	0	0	0	1	1	7:15 AM	0	0	0	0	0
7:30 AM	1	7	0	5	13	7:30 AM	0	1	0	1	2	7:30 AM	1	1	1	0	3
7:45 AM	0	9	0	10	19	7:45 AM	0	0	0	0	0	7:45 AM	0	0	0	0	0
8:00 AM	0	7	0	13	20	8:00 AM	0	0	0	1	1	8:00 AM	0	0	0	0	0
8:15 AM	0	7	0	25	32	8:15 AM	0	0	0	0	0	8:15 AM	0	1	0	0	1
Count Total	1	54	0	81	136	Count Total	0	1	0	3	4	Count Total	1	2	2	0	5
Peak Hour	1	30	0	53	84	Peak Hour	0	1	0	2	3	Peak Hour	1	2	1	0	4

Peak Hour

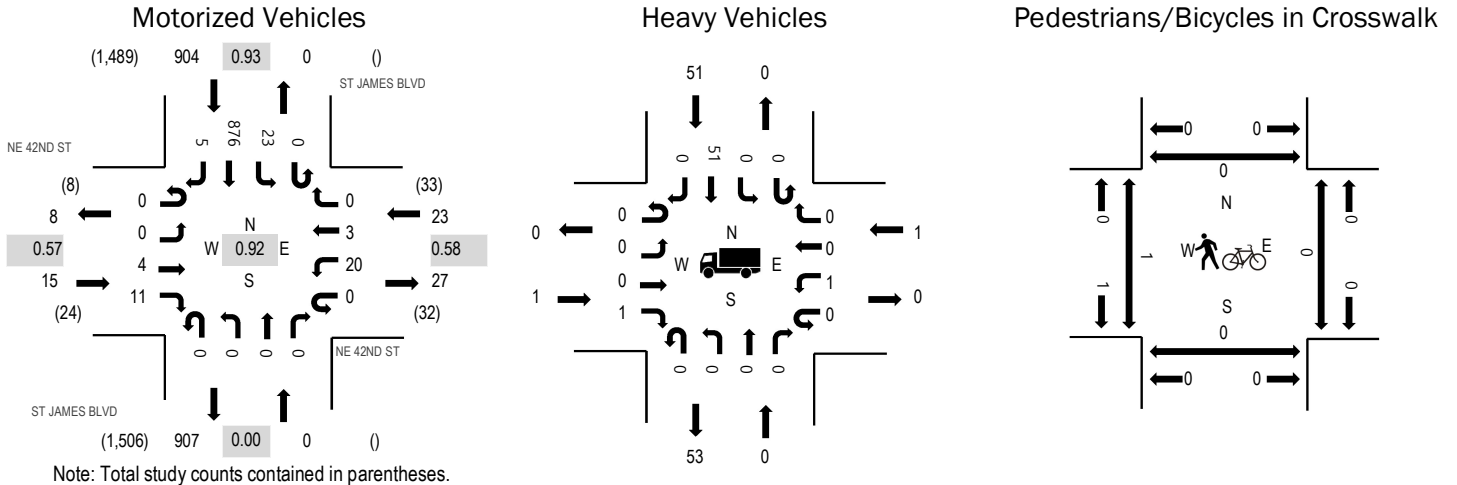

	HV%	PHF
EB	6.7%	0.57
WB	4.3%	0.58
NB	0.0%	0.00
SB	5.6%	0.93
All	5.6%	0.92

Traffic Counts - Motorized Vehicles

Interval Start Time	NE 42ND ST Eastbound				NE 42ND ST Westbound				ST JAMES BLVD Northbound				ST JAMES BLVD Southbound				Total	Rolling Hour
	U-Turn	Left	Thru	Right	U-Turn	Left	Thru	Right	U-Turn	Left	Thru	Right	U-Turn	Left	Thru	Right		
6:30 AM	0	0	0	4	0	3	0	0	0	0	0	0	0	0	122	0	129	604
6:45 AM	0	0	0	2	0	2	0	0	0	0	0	0	0	0	139	0	143	692
7:00 AM	0	0	0	2	0	1	0	0	0	0	0	0	0	0	145	0	148	805
7:15 AM	0	0	0	1	0	4	0	0	0	0	0	0	0	5	174	0	184	887
7:30 AM	0	0	1	3	0	8	2	0	0	0	0	0	0	4	197	2	217	942
7:45 AM	0	0	2	5	0	5	0	0	0	0	0	0	0	5	239	0	256	
8:00 AM	0	0	1	3	0	2	1	0	0	0	0	0	0	6	216	1	230	
8:15 AM	0	0	0	0	0	5	0	0	0	0	0	0	0	8	224	2	239	
Count Total	0	0	4	20	0	30	3	0	0	0	0	0	0	28	1,456	5	1,546	
Peak Hour	0	0	4	11	0	20	3	0	0	0	0	0	0	23	876	5	942	

Traffic Counts - Heavy Vehicles, Bicycles on Road, and Pedestrians/Bicycles in Crosswalk

Interval Start Time	Heavy Vehicles					Interval Start Time	Bicycles on Roadway					Interval Start Time	Pedestrians/Bicycles on Crosswalk				
	EB	NB	WB	SB	Total		EB	NB	WB	SB	Total		EB	NB	WB	SB	Total
6:30 AM	0	0	0	4	4	6:30 AM	0	0	0	0	0	6:30 AM	0	0	0	0	0
6:45 AM	0	0	0	7	7	6:45 AM	0	0	0	0	0	6:45 AM	0	0	0	0	0
7:00 AM	0	0	0	5	5	7:00 AM	0	0	0	0	0	7:00 AM	0	0	0	0	0
7:15 AM	0	0	1	12	13	7:15 AM	0	0	0	1	1	7:15 AM	0	0	0	0	0
7:30 AM	1	0	1	3	5	7:30 AM	0	0	0	1	1	7:30 AM	0	0	0	0	0
7:45 AM	0	0	0	10	10	7:45 AM	0	0	0	0	0	7:45 AM	0	0	0	0	0
8:00 AM	0	0	0	13	13	8:00 AM	0	0	0	1	1	8:00 AM	1	0	0	0	1
8:15 AM	0	0	0	25	25	8:15 AM	0	0	0	0	0	8:15 AM	0	0	0	0	0
Count Total	1	0	2	79	82	Count Total	0	0	0	3	3	Count Total	1	0	0	0	1
Peak Hour	1	0	1	51	53	Peak Hour	0	0	0	2	2	Peak Hour	1	0	0	0	1

Peak Hour

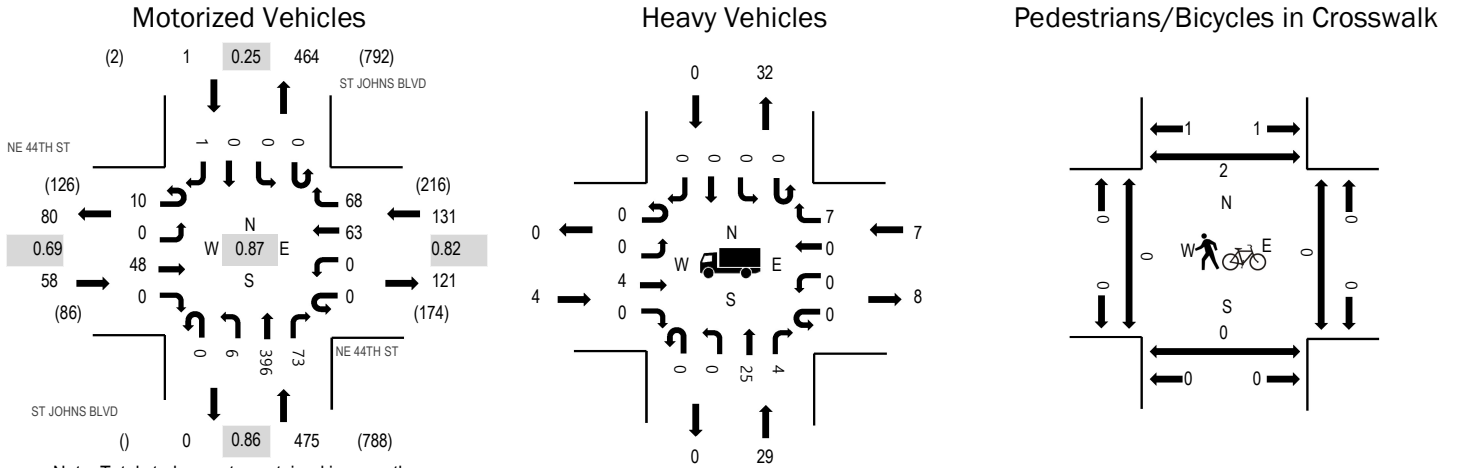

Note: Total study counts contained in parentheses.

	HV%	PHF
EB	6.9%	0.69
WB	5.3%	0.82
NB	6.1%	0.86
SB	0.0%	0.25
All	6.0%	0.87

Traffic Counts - Motorized Vehicles

Interval Start Time	NE 44TH ST Eastbound				NE 44TH ST Westbound				ST JOHNS BLVD Northbound				ST JOHNS BLVD Southbound				Total	Rolling Hour
	U-Turn	Left	Thru	Right	U-Turn	Left	Thru	Right	U-Turn	Left	Thru	Right	U-Turn	Left	Thru	Right		
6:30 AM	2	0	3	0	0	0	12	14	0	1	54	4	0	0	0	0	90	427
6:45 AM	2	0	7	0	0	0	8	12	0	0	82	3	0	0	0	1	115	476
7:00 AM	1	0	4	0	0	0	8	9	0	0	70	9	0	0	0	0	101	553
7:15 AM	2	0	7	0	0	0	7	15	0	2	72	16	0	0	0	0	121	628
7:30 AM	2	0	7	0	0	0	14	18	0	1	79	18	0	0	0	0	139	665
7:45 AM	3	0	18	0	0	0	13	20	0	0	118	20	0	0	0	0	192	
8:00 AM	3	0	12	0	0	0	24	16	0	2	101	18	0	0	0	0	176	
8:15 AM	2	0	11	0	0	0	12	14	0	3	98	17	0	0	0	1	158	
Count Total	17	0	69	0	0	0	98	118	0	9	674	105	0	0	0	2	1,092	
Peak Hour	10	0	48	0	0	0	63	68	0	6	396	73	0	0	0	1	665	

Traffic Counts - Heavy Vehicles, Bicycles on Road, and Pedestrians/Bicycles in Crosswalk

Interval Start Time	Heavy Vehicles					Interval Start Time	Bicycles on Roadway					Interval Start Time	Pedestrians/Bicycles on Crosswalk				
	EB	NB	WB	SB	Total		EB	NB	WB	SB	Total		EB	NB	WB	SB	Total
6:30 AM	0	2	1	0	3	6:30 AM	0	0	0	0	0	6:30 AM	0	0	0	0	0
6:45 AM	1	5	1	0	7	6:45 AM	0	0	0	0	0	6:45 AM	1	0	1	0	2
7:00 AM	1	10	1	0	12	7:00 AM	0	0	0	0	0	7:00 AM	0	0	0	0	0
7:15 AM	1	7	2	0	10	7:15 AM	0	0	0	0	0	7:15 AM	0	1	0	0	1
7:30 AM	0	6	1	0	7	7:30 AM	0	0	0	0	0	7:30 AM	0	0	0	2	2
7:45 AM	1	9	5	0	15	7:45 AM	0	0	0	0	0	7:45 AM	0	0	0	0	0
8:00 AM	1	7	1	0	9	8:00 AM	0	0	0	0	0	8:00 AM	0	0	0	0	0
8:15 AM	2	7	0	0	9	8:15 AM	0	0	0	0	0	8:15 AM	0	0	0	0	0
Count Total	7	53	12	0	72	Count Total	0	0	0	0	0	Count Total	1	1	1	2	5
Peak Hour	4	29	7	0	40	Peak Hour	0	0	0	0	0	Peak Hour	0	0	0	2	2

Peak Hour

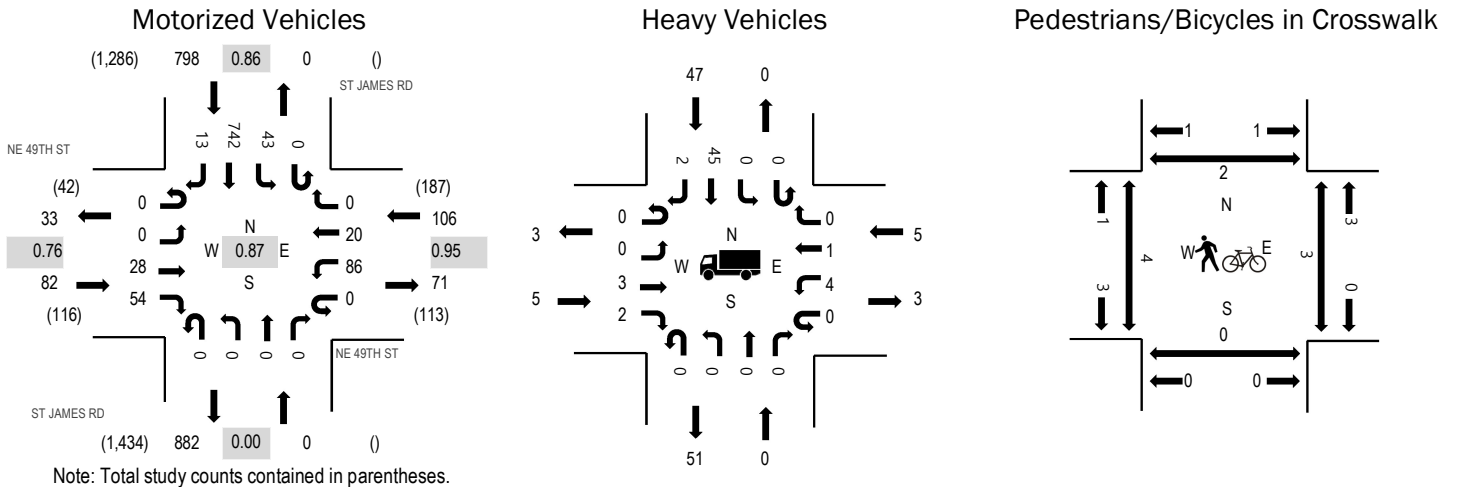

	HV%	PHF
EB	6.1%	0.76
WB	4.7%	0.95
NB	0.0%	0.00
SB	5.9%	0.86
All	5.8%	0.87

Traffic Counts - Motorized Vehicles

Interval Start Time	NE 49TH ST Eastbound				NE 49TH ST Westbound				ST JAMES RD Northbound				ST JAMES RD Southbound				Total	Rolling Hour
	U-Turn	Left	Thru	Right	U-Turn	Left	Thru	Right	U-Turn	Left	Thru	Right	U-Turn	Left	Thru	Right		
6:30 AM	0	0	2	4	0	19	2	0	0	0	0	0	0	8	83	0	118	603
6:45 AM	0	0	1	3	0	22	2	0	0	0	0	0	0	7	107	1	143	706
7:00 AM	0	0	3	7	0	17	3	0	0	0	0	0	0	7	127	1	165	847
7:15 AM	0	0	4	10	0	16	0	0	0	0	0	0	0	10	137	0	177	909
7:30 AM	0	0	4	8	0	22	4	0	0	0	0	0	0	10	172	1	221	986
7:45 AM	0	0	11	16	0	22	4	0	0	0	0	0	0	16	208	7	284	
8:00 AM	0	0	8	16	0	22	6	0	0	0	0	0	0	9	163	3	227	
8:15 AM	0	0	5	14	0	20	6	0	0	0	0	0	0	8	199	2	254	
Count Total	0	0	38	78	0	160	27	0	0	0	0	0	0	75	1,196	15	1,589	
Peak Hour	0	0	28	54	0	86	20	0	0	0	0	0	0	43	742	13	986	

Traffic Counts - Heavy Vehicles, Bicycles on Road, and Pedestrians/Bicycles in Crosswalk

Interval Start Time	Heavy Vehicles					Interval Start Time	Bicycles on Roadway					Interval Start Time	Pedestrians/Bicycles on Crosswalk				
	EB	NB	WB	SB	Total		EB	NB	WB	SB	Total		EB	NB	WB	SB	Total
6:30 AM	1	0	0	3	4	6:30 AM	0	0	0	0	0	6:30 AM	0	0	0	0	0
6:45 AM	0	0	1	7	8	6:45 AM	0	0	0	0	0	6:45 AM	0	0	0	0	0
7:00 AM	0	0	0	5	5	7:00 AM	0	0	0	0	0	7:00 AM	0	0	0	0	0
7:15 AM	1	0	2	11	14	7:15 AM	0	0	1	0	1	7:15 AM	1	0	0	0	1
7:30 AM	0	0	1	4	5	7:30 AM	0	0	0	0	0	7:30 AM	1	0	0	0	1
7:45 AM	3	0	1	9	13	7:45 AM	0	0	1	0	1	7:45 AM	2	0	1	1	4
8:00 AM	2	0	2	10	14	8:00 AM	0	0	0	0	0	8:00 AM	0	0	2	0	2
8:15 AM	0	0	1	24	25	8:15 AM	0	0	0	0	0	8:15 AM	1	0	0	1	2
Count Total	7	0	8	73	88	Count Total	0	0	2	0	2	Count Total	5	0	3	2	10
Peak Hour	5	0	5	47	57	Peak Hour	0	0	1	0	1	Peak Hour	4	0	3	2	9

Peak Hour

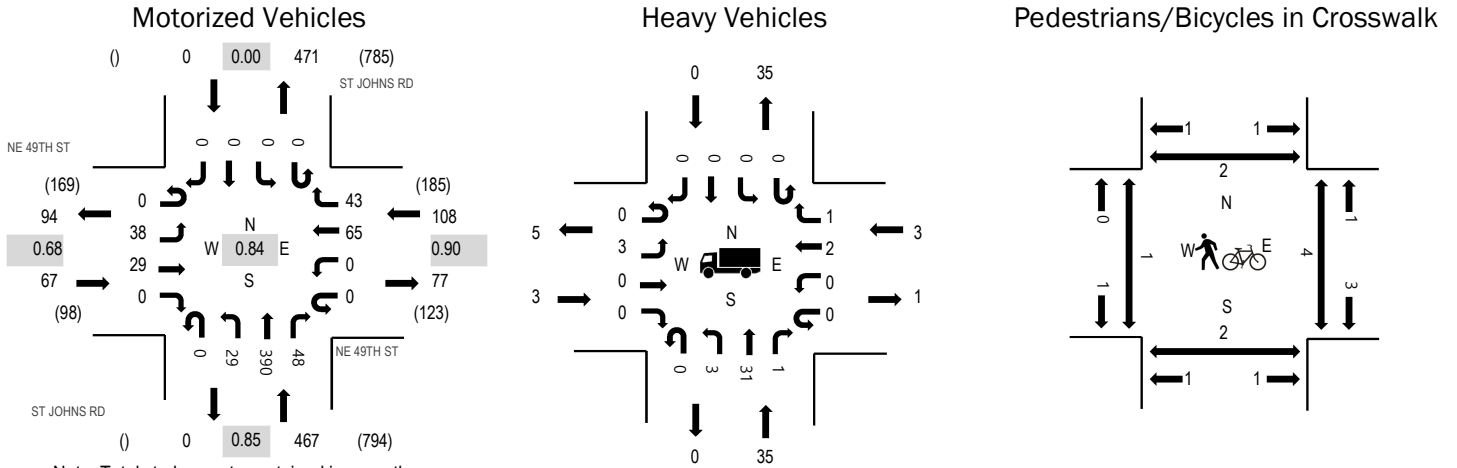

Note: Total study counts contained in parentheses.

	HV%	PHF
EB	4.5%	0.68
WB	2.8%	0.90
NB	7.5%	0.85
SB	0.0%	0.00
All	6.4%	0.84

Traffic Counts - Motorized Vehicles

Interval Start Time	NE 49TH ST Eastbound				NE 49TH ST Westbound				ST JOHNS RD Northbound				ST JOHNS RD Southbound				Total	Rolling Hour
	U-Turn	Left	Thru	Right	U-Turn	Left	Thru	Right	U-Turn	Left	Thru	Right	U-Turn	Left	Thru	Right		
6:30 AM	0	4	3	0	0	0	11	3	0	8	60	4	0	0	0	0	93	435
6:45 AM	0	1	4	0	0	0	18	10	0	3	74	7	0	0	0	0	117	486
7:00 AM	0	0	7	0	0	0	12	8	0	7	66	7	0	0	0	0	107	561
7:15 AM	0	4	8	0	0	0	7	8	0	9	76	6	0	0	0	0	118	617
7:30 AM	0	8	8	0	0	0	14	6	0	9	90	9	0	0	0	0	144	642
7:45 AM	0	17	8	0	0	0	19	10	0	4	118	16	0	0	0	0	192	
8:00 AM	0	9	6	0	0	0	15	14	0	10	96	13	0	0	0	0	163	
8:15 AM	0	4	7	0	0	0	17	13	0	6	86	10	0	0	0	0	143	
Count Total	0	47	51	0	0	0	113	72	0	56	666	72	0	0	0	0	1,077	
Peak Hour	0	38	29	0	0	0	65	43	0	29	390	48	0	0	0	0	642	

Traffic Counts - Heavy Vehicles, Bicycles on Road, and Pedestrians/Bicycles in Crosswalk

Interval Start Time	Heavy Vehicles					Interval Start Time	Bicycles on Roadway					Interval Start Time	Pedestrians/Bicycles on Crosswalk				
	EB	NB	WB	SB	Total		EB	NB	WB	SB	Total		EB	NB	WB	SB	Total
6:30 AM	0	3	0	0	3	6:30 AM	0	0	0	0	0	6:30 AM	0	1	0	0	1
6:45 AM	0	6	0	0	6	6:45 AM	0	0	0	0	0	6:45 AM	0	0	0	0	0
7:00 AM	0	11	0	0	11	7:00 AM	0	0	0	0	0	7:00 AM	0	0	0	0	0
7:15 AM	2	10	0	0	12	7:15 AM	0	0	1	0	1	7:15 AM	0	0	0	0	0
7:30 AM	0	8	1	0	9	7:30 AM	0	0	0	0	0	7:30 AM	0	0	0	0	0
7:45 AM	1	11	1	0	13	7:45 AM	0	0	1	0	1	7:45 AM	0	1	1	1	3
8:00 AM	2	10	0	0	12	8:00 AM	0	0	0	0	0	8:00 AM	1	1	2	0	4
8:15 AM	0	6	1	0	7	8:15 AM	0	0	0	0	0	8:15 AM	0	0	1	1	2
Count Total	5	65	3	0	73	Count Total	0	0	2	0	2	Count Total	1	3	4	2	10
Peak Hour	3	35	3	0	41	Peak Hour	0	0	1	0	1	Peak Hour	1	2	4	2	9

Peak Hour

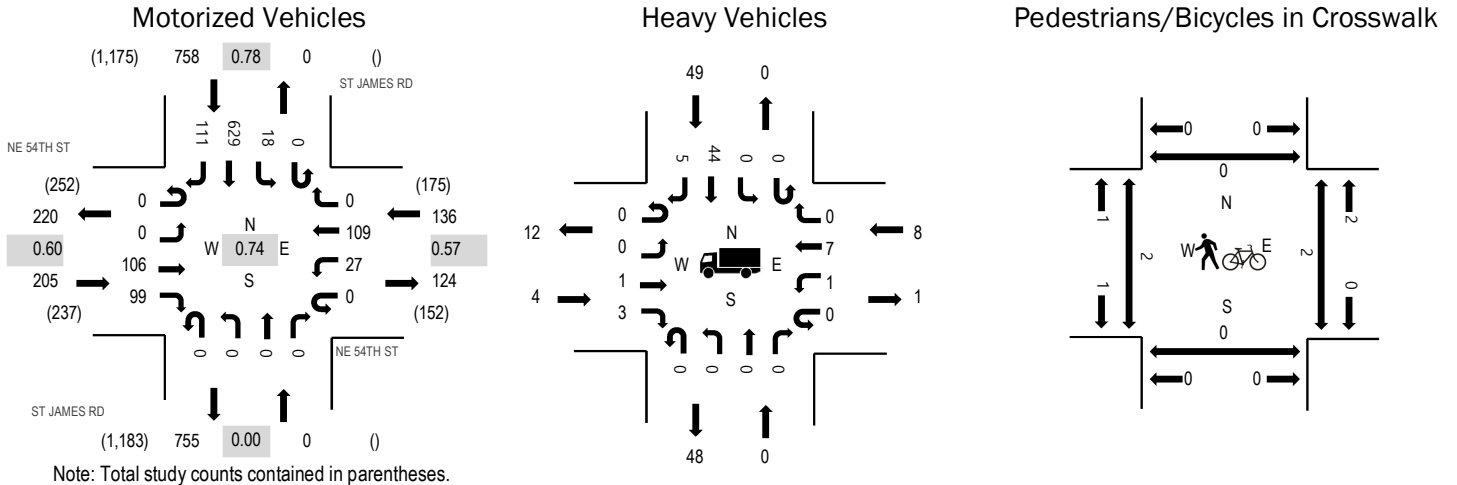

	HV%	PHF
EB	2.0%	0.60
WB	5.9%	0.57
NB	0.0%	0.00
SB	6.5%	0.78
All	5.6%	0.74

Traffic Counts - Motorized Vehicles

Interval Start Time	NE 54TH ST Eastbound				NE 54TH ST Westbound				ST JAMES RD Northbound				ST JAMES RD Southbound				Total	Rolling Hour
	U-Turn	Left	Thru	Right	U-Turn	Left	Thru	Right	U-Turn	Left	Thru	Right	U-Turn	Left	Thru	Right		
6:30 AM	0	0	2	6	0	6	3	0	0	0	0	0	0	2	65	2	86	488
6:45 AM	0	0	4	5	0	5	3	0	0	0	0	0	0	5	84	5	111	610
7:00 AM	0	0	5	2	0	7	5	0	0	0	0	0	0	2	111	3	135	872
7:15 AM	0	0	3	5	0	6	4	0	0	0	0	0	0	5	126	7	156	1,018
7:30 AM	0	0	4	11	0	9	23	0	0	0	0	0	0	3	135	23	208	1,099
7:45 AM	0	0	40	31	0	10	50	0	0	0	0	0	0	3	190	49	373	
8:00 AM	0	0	46	39	0	3	28	0	0	0	0	0	0	6	136	23	281	
8:15 AM	0	0	16	18	0	5	8	0	0	0	0	0	0	6	168	16	237	
Count Total	0	0	120	117	0	51	124	0	0	0	0	0	0	32	1,015	128	1,587	
Peak Hour	0	0	106	99	0	27	109	0	0	0	0	0	0	18	629	111	1,099	

Traffic Counts - Heavy Vehicles, Bicycles on Road, and Pedestrians/Bicycles in Crosswalk

Interval Start Time	Heavy Vehicles					Interval Start Time	Bicycles on Roadway					Interval Start Time	Pedestrians/Bicycles on Crosswalk				
	EB	NB	WB	SB	Total		EB	NB	WB	SB	Total		EB	NB	WB	SB	Total
6:30 AM	0	0	0	4	4	6:30 AM	0	0	0	0	0	6:30 AM	0	0	0	0	0
6:45 AM	2	0	0	7	9	6:45 AM	0	0	0	0	0	6:45 AM	0	0	0	0	0
7:00 AM	1	0	3	9	13	7:00 AM	0	0	0	0	0	7:00 AM	0	0	0	0	0
7:15 AM	0	0	0	12	12	7:15 AM	1	0	0	0	1	7:15 AM	1	0	0	0	1
7:30 AM	0	0	3	10	13	7:30 AM	0	0	0	0	0	7:30 AM	2	0	0	0	2
7:45 AM	0	0	4	9	13	7:45 AM	0	0	0	0	0	7:45 AM	0	0	0	0	0
8:00 AM	1	0	1	12	14	8:00 AM	0	0	0	0	0	8:00 AM	0	0	2	0	2
8:15 AM	3	0	0	18	21	8:15 AM	0	0	0	0	0	8:15 AM	0	0	0	0	0
Count Total	7	0	11	81	99	Count Total	1	0	0	0	1	Count Total	3	0	2	0	5
Peak Hour	4	0	8	49	61	Peak Hour	0	0	0	0	0	Peak Hour	2	0	2	0	4

Peak Hour

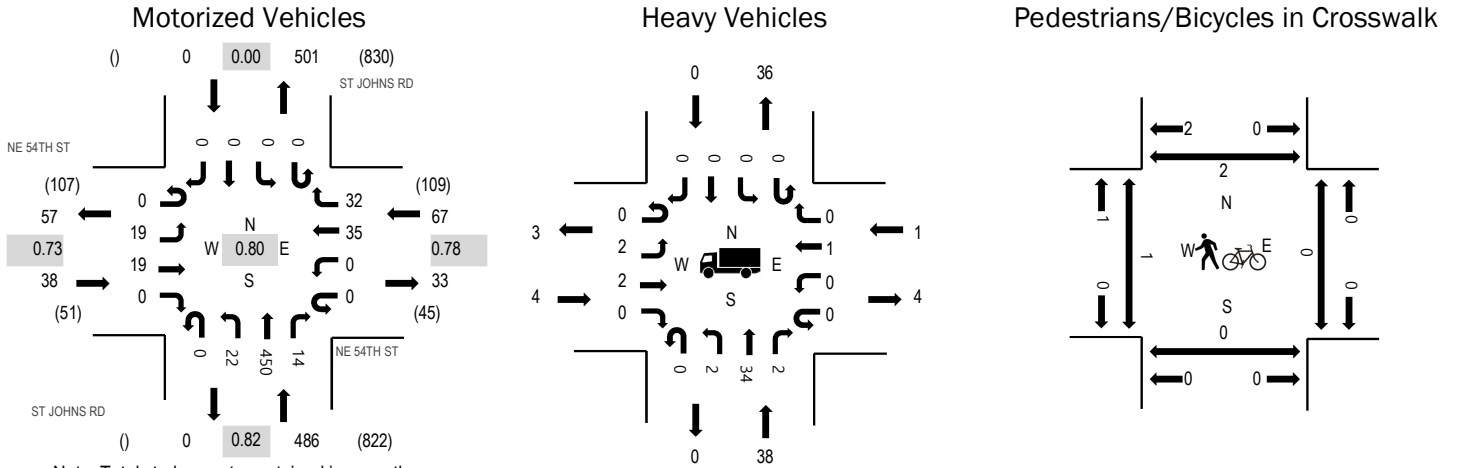

Note: Total study counts contained in parentheses.

	HV%	PHF
EB	10.5%	0.73
WB	1.5%	0.78
NB	7.8%	0.82
SB	0.0%	0.00
All	7.3%	0.80

Traffic Counts - Motorized Vehicles

Interval Start Time	NE 54TH ST Eastbound				NE 54TH ST Westbound				ST JOHNS RD Northbound				ST JOHNS RD Southbound				Total	Rolling Hour
	U-Turn	Left	Thru	Right	U-Turn	Left	Thru	Right	U-Turn	Left	Thru	Right	U-Turn	Left	Thru	Right		
6:30 AM	0	0	1	0	0	0	8	3	0	3	72	0	0	0	0	0	87	391
6:45 AM	0	2	0	0	0	0	5	5	0	4	78	2	0	0	0	0	96	440
7:00 AM	0	2	1	0	0	0	8	2	0	7	68	2	0	0	0	0	90	528
7:15 AM	0	5	2	0	0	0	9	2	0	6	90	4	0	0	0	0	118	581
7:30 AM	0	5	2	0	0	0	11	7	0	5	103	3	0	0	0	0	136	591
7:45 AM	0	6	8	0	0	0	8	14	0	3	140	5	0	0	0	0	184	
8:00 AM	0	6	7	0	0	0	9	9	0	7	104	1	0	0	0	0	143	
8:15 AM	0	2	2	0	0	0	7	2	0	7	103	5	0	0	0	0	128	
Count Total	0	28	23	0	0	0	65	44	0	42	758	22	0	0	0	0	982	
Peak Hour	0	19	19	0	0	0	35	32	0	22	450	14	0	0	0	0	591	

Traffic Counts - Heavy Vehicles, Bicycles on Road, and Pedestrians/Bicycles in Crosswalk

Interval Start Time	Heavy Vehicles					Interval Start Time	Bicycles on Roadway					Interval Start Time	Pedestrians/Bicycles on Crosswalk				
	EB	NB	WB	SB	Total		EB	NB	WB	SB	Total		EB	NB	WB	SB	Total
6:30 AM	0	3	0	0	3	6:30 AM	0	0	0	0	0	6:30 AM	0	0	0	0	0
6:45 AM	0	5	0	0	5	6:45 AM	0	0	0	0	0	6:45 AM	0	0	0	0	0
7:00 AM	0	12	1	0	13	7:00 AM	0	0	0	0	0	7:00 AM	0	0	0	0	0
7:15 AM	1	8	0	0	9	7:15 AM	0	0	0	0	0	7:15 AM	0	0	0	0	0
7:30 AM	1	11	1	0	13	7:30 AM	0	0	2	0	2	7:30 AM	0	0	0	0	0
7:45 AM	2	12	0	0	14	7:45 AM	0	0	0	0	0	7:45 AM	1	0	0	0	1
8:00 AM	0	6	0	0	6	8:00 AM	0	0	1	0	1	8:00 AM	0	0	0	2	2
8:15 AM	1	9	0	0	10	8:15 AM	0	0	0	0	0	8:15 AM	0	0	0	0	0
Count Total	5	66	2	0	73	Count Total	0	0	3	0	3	Count Total	1	0	0	2	3
Peak Hour	4	38	1	0	43	Peak Hour	0	0	3	0	3	Peak Hour	1	0	0	2	3

Peak Hour

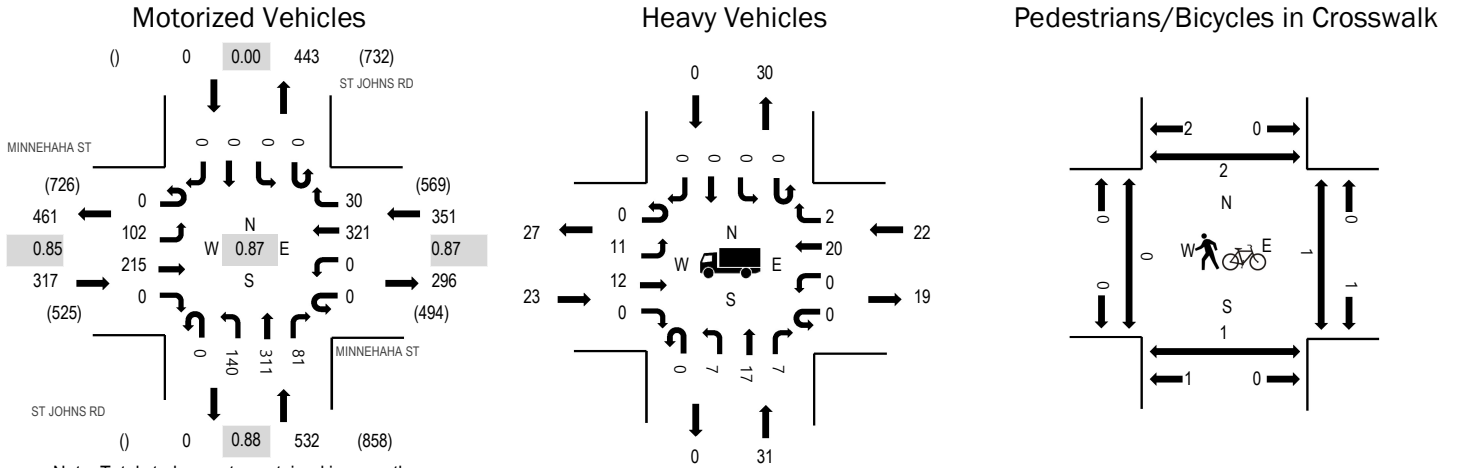

Note: Total study counts contained in parentheses.

	HV%	PHF
EB	7.3%	0.85
WB	6.3%	0.87
NB	5.8%	0.88
SB	0.0%	0.00
All	6.3%	0.87

Traffic Counts - Motorized Vehicles

Interval Start Time	MINNEHAHA ST Eastbound				MINNEHAHA ST Westbound				ST JOHNS RD Northbound				ST JOHNS RD Southbound				Total	Rolling Hour
	U-Turn	Left	Thru	Right	U-Turn	Left	Thru	Right	U-Turn	Left	Thru	Right	U-Turn	Left	Thru	Right		
6:30 AM	0	10	30	0	0	0	50	4	0	14	50	11	0	0	0	0	169	752
6:45 AM	0	15	35	0	0	0	47	9	0	24	62	10	0	0	0	0	202	844
7:00 AM	0	19	32	0	0	0	49	6	0	12	49	14	0	0	0	0	181	986
7:15 AM	0	16	51	0	0	0	46	7	0	23	42	15	0	0	0	0	200	1,124
7:30 AM	0	18	44	0	0	0	69	10	0	34	73	13	0	0	0	0	261	1,200
7:45 AM	0	34	57	0	0	0	92	9	0	31	91	30	0	0	0	0	344	
8:00 AM	0	26	67	0	0	0	81	5	0	37	82	21	0	0	0	0	319	
8:15 AM	0	24	47	0	0	0	79	6	0	38	65	17	0	0	0	0	276	
Count Total	0	162	363	0	0	0	513	56	0	213	514	131	0	0	0	0	1,952	
Peak Hour	0	102	215	0	0	0	321	30	0	140	311	81	0	0	0	0	1,200	

Traffic Counts - Heavy Vehicles, Bicycles on Road, and Pedestrians/Bicycles in Crosswalk

Interval Start Time	Heavy Vehicles					Interval Start Time	Bicycles on Roadway					Interval Start Time	Pedestrians/Bicycles on Crosswalk				
	EB	NB	WB	SB	Total		EB	NB	WB	SB	Total		EB	NB	WB	SB	Total
6:30 AM	3	2	5	0	10	6:30 AM	0	0	0	0	0	6:30 AM	0	0	0	0	0
6:45 AM	4	5	2	0	11	6:45 AM	0	0	0	0	0	6:45 AM	0	2	0	0	2
7:00 AM	3	6	4	0	13	7:00 AM	0	0	0	0	0	7:00 AM	0	0	1	1	2
7:15 AM	5	7	7	0	19	7:15 AM	0	0	0	0	0	7:15 AM	0	0	0	1	1
7:30 AM	4	7	5	0	16	7:30 AM	0	1	0	0	1	7:30 AM	0	0	0	0	0
7:45 AM	5	10	4	0	19	7:45 AM	0	0	0	0	0	7:45 AM	0	0	0	0	0
8:00 AM	8	8	7	0	23	8:00 AM	0	0	0	0	0	8:00 AM	0	1	0	1	2
8:15 AM	6	6	6	0	18	8:15 AM	0	0	0	0	0	8:15 AM	0	0	1	1	2
Count Total	38	51	40	0	129	Count Total	0	1	0	0	1	Count Total	0	3	2	4	9
Peak Hour	23	31	22	0	76	Peak Hour	0	1	0	0	1	Peak Hour	0	1	1	2	4

Peak Hour

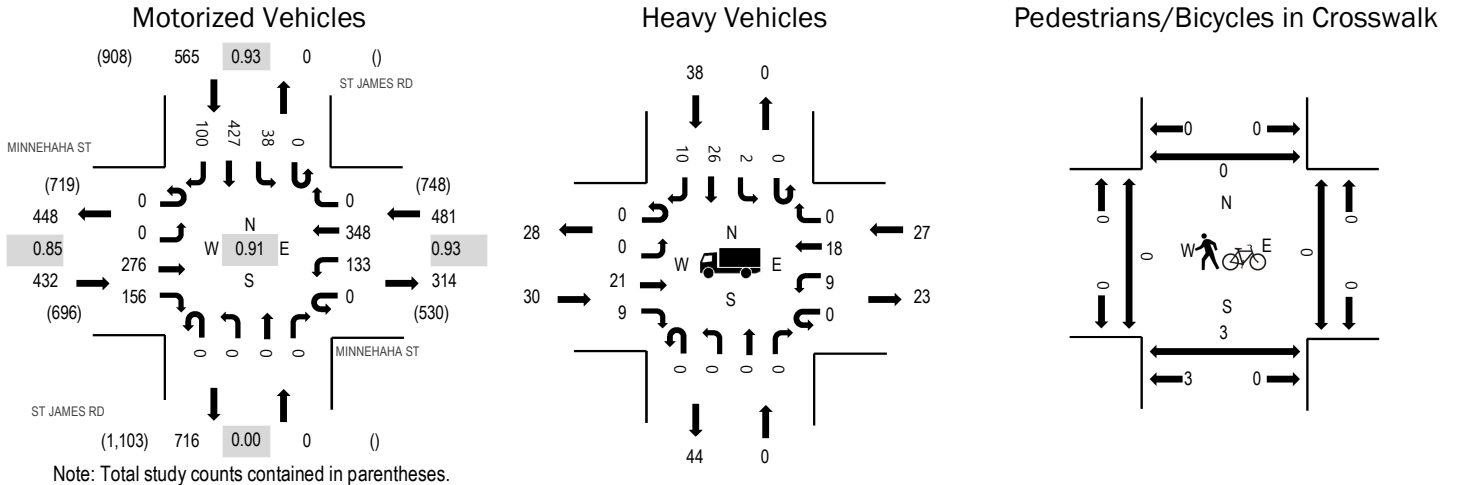

	HV%	PHF
EB	6.9%	0.85
WB	5.6%	0.93
NB	0.0%	0.00
SB	6.7%	0.93
All	6.4%	0.91

Traffic Counts - Motorized Vehicles

Interval Start Time	MINNEHAHA ST Eastbound				MINNEHAHA ST Westbound				ST JAMES RD Northbound				ST JAMES RD Southbound				Total	Rolling Hour
	U-Turn	Left	Thru	Right	U-Turn	Left	Thru	Right	U-Turn	Left	Thru	Right	U-Turn	Left	Thru	Right		
6:30 AM	0	0	34	13	0	9	57	0	0	0	0	0	0	4	40	17	174	874
6:45 AM	0	0	51	20	0	11	61	0	0	0	0	0	0	4	55	12	214	1,047
7:00 AM	0	0	41	21	0	24	40	0	0	0	0	0	0	11	76	11	224	1,241
7:15 AM	1	0	58	25	0	12	53	0	0	0	0	0	0	13	81	19	262	1,402
7:30 AM	0	0	56	42	0	24	82	0	0	0	0	0	0	11	104	28	347	1,478
7:45 AM	0	0	80	47	0	43	86	0	0	0	0	0	0	9	117	26	408	
8:00 AM	0	0	84	37	0	28	95	0	0	0	0	0	0	7	108	26	385	
8:15 AM	0	0	56	30	0	38	85	0	0	0	0	0	0	11	98	20	338	
Count Total	1	0	460	235	0	189	559	0	0	0	0	0	0	70	679	159	2,352	
Peak Hour	0	0	276	156	0	133	348	0	0	0	0	0	0	38	427	100	1,478	

Traffic Counts - Heavy Vehicles, Bicycles on Road, and Pedestrians/Bicycles in Crosswalk

Interval Start Time	Heavy Vehicles					Interval Start Time	Bicycles on Roadway					Interval Start Time	Pedestrians/Bicycles on Crosswalk				
	EB	NB	WB	SB	Total		EB	NB	WB	SB	Total		EB	NB	WB	SB	Total
6:30 AM	3	0	5	1	9	6:30 AM	0	0	0	0	0	6:30 AM	1	0	0	0	1
6:45 AM	4	0	3	4	11	6:45 AM	0	0	0	0	0	6:45 AM	0	0	0	0	0
7:00 AM	6	0	6	4	16	7:00 AM	0	0	0	0	0	7:00 AM	0	0	0	1	1
7:15 AM	6	0	7	11	24	7:15 AM	0	0	0	0	0	7:15 AM	1	0	0	1	2
7:30 AM	8	0	7	8	23	7:30 AM	0	0	0	0	0	7:30 AM	0	0	0	0	0
7:45 AM	5	0	4	8	17	7:45 AM	0	0	0	0	0	7:45 AM	0	0	0	0	0
8:00 AM	7	0	9	8	24	8:00 AM	0	0	0	0	0	8:00 AM	0	1	0	0	1
8:15 AM	10	0	7	14	31	8:15 AM	0	0	0	1	1	8:15 AM	0	2	0	0	2
Count Total	49	0	48	58	155	Count Total	0	0	0	1	1	Count Total	2	3	0	2	7
Peak Hour	30	0	27	38	95	Peak Hour	0	0	0	1	1	Peak Hour	0	3	0	0	3

Location: 1 ST JOHNS BLVD & 4TH PLAIN BLVD PM

Date: Thursday, December 14, 2023

Peak Hour: 04:00 PM - 05:00 PM

Peak 15-Minutes: 04:00 PM - 04:15 PM

Peak Hour

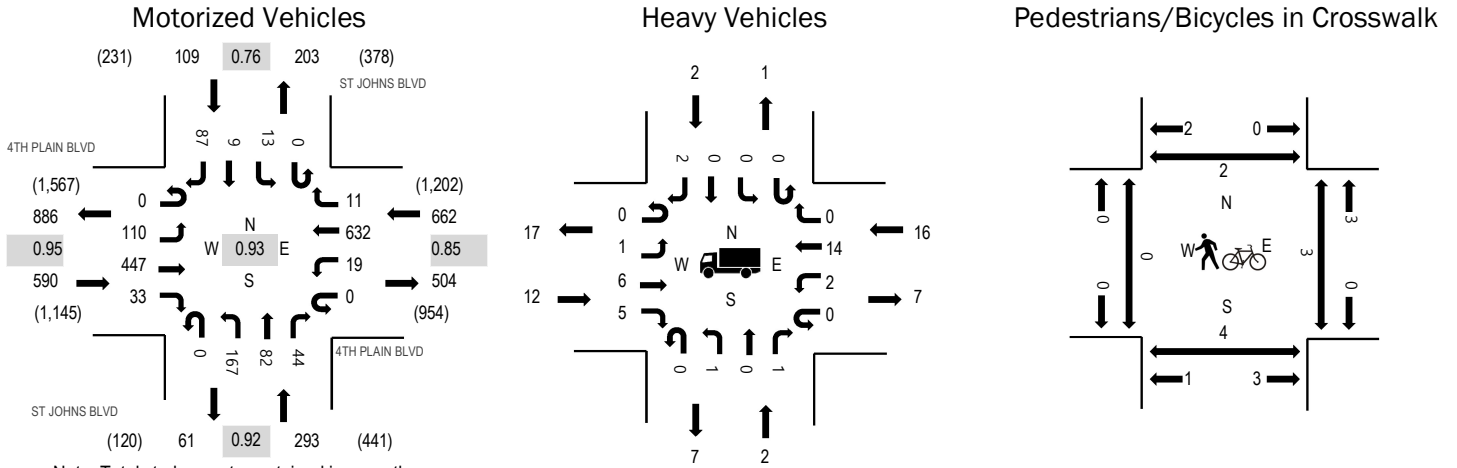

Note: Total study counts contained in parentheses.

	HV%	PHF
EB	2.0%	0.95
WB	2.4%	0.85
NB	0.7%	0.92
SB	1.8%	0.76
All	1.9%	0.93

Traffic Counts - Motorized Vehicles

Interval Start Time	4TH PLAIN BLVD Eastbound				4TH PLAIN BLVD Westbound				ST JOHNS BLVD Northbound				ST JOHNS BLVD Southbound				Total	Rolling Hour
	U-Turn	Left	Thru	Right	U-Turn	Left	Thru	Right	U-Turn	Left	Thru	Right	U-Turn	Left	Thru	Right		
4:00 PM	0	28	113	6	0	5	186	4	0	47	20	13	0	2	1	22	447	1,654
4:15 PM	0	29	114	12	0	6	156	2	0	41	27	12	0	4	5	21	429	1,593
4:30 PM	0	21	118	7	0	2	150	1	0	46	21	12	0	3	0	26	407	1,501
4:45 PM	0	32	102	8	0	6	140	4	0	33	14	7	0	4	3	18	371	1,452
5:00 PM	0	29	108	4	0	3	158	7	0	32	14	5	0	3	3	20	386	1,365
5:15 PM	0	28	108	5	0	9	113	4	0	21	10	7	0	2	4	26	337	
5:30 PM	0	25	119	11	0	1	124	3	0	16	10	8	9	3	5	24	358	
5:45 PM	0	26	84	8	0	2	115	1	0	14	9	2	0	1	4	18	284	
Count Total	0	218	866	61	0	34	1,142	26	0	250	125	66	9	22	25	175	3,019	
Peak Hour	0	110	447	33	0	19	632	11	0	167	82	44	0	13	9	87	1,654	

Traffic Counts - Heavy Vehicles, Bicycles on Road, and Pedestrians/Bicycles in Crosswalk

Interval Start Time	Heavy Vehicles					Interval Start Time	Bicycles on Roadway					Interval Start Time	Pedestrians/Bicycles on Crosswalk				
	EB	NB	WB	SB	Total		EB	NB	WB	SB	Total		EB	NB	WB	SB	Total
4:00 PM	2	0	4	0	6	4:00 PM	0	0	0	0	0	4:00 PM	0	0	1	0	1
4:15 PM	3	2	6	1	12	4:15 PM	0	0	0	0	0	4:15 PM	0	0	1	1	2
4:30 PM	4	0	3	1	8	4:30 PM	0	0	0	0	0	4:30 PM	0	2	1	1	4
4:45 PM	3	0	3	0	6	4:45 PM	0	0	0	0	0	4:45 PM	0	2	0	0	2
5:00 PM	2	2	0	0	4	5:00 PM	0	1	0	0	1	5:00 PM	0	0	0	0	0
5:15 PM	3	1	1	0	5	5:15 PM	0	0	0	0	0	5:15 PM	0	0	1	2	3
5:30 PM	3	2	0	0	5	5:30 PM	0	0	0	0	0	5:30 PM	0	0	0	0	0
5:45 PM	2	2	2	0	6	5:45 PM	0	0	0	0	0	5:45 PM	0	1	1	0	2
Count Total	22	9	19	2	52	Count Total	0	1	0	0	1	Count Total	0	5	5	4	14
Peak Hour	12	2	16	2	32	Peak Hour	0	0	0	0	0	Peak Hour	0	4	3	2	9

Peak Hour

Motorized Vehicles

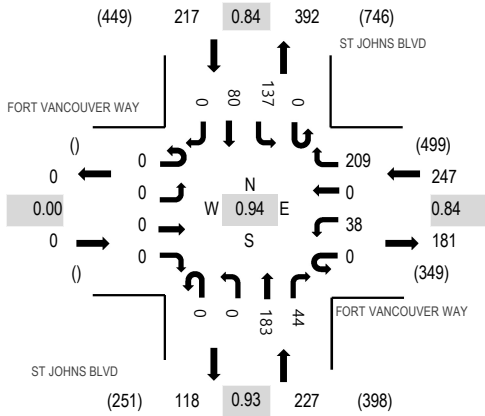

Heavy Vehicles

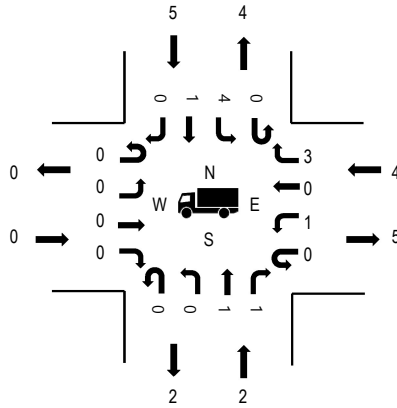

Pedestrians/Bicycles in Crosswalk

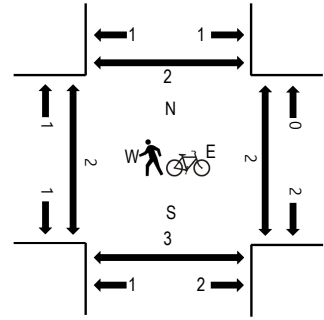

Note: Total study counts contained in parentheses.

	HV%	PHF
EB	0.0%	0.00
WB	1.6%	0.84
NB	0.9%	0.93
SB	2.3%	0.84
All	1.6%	0.94

Traffic Counts - Motorized Vehicles

Interval Start Time	FORT VANCOUVER WAY Eastbound				FORT VANCOUVER WAY Westbound				ST JOHNS BLVD Northbound				ST JOHNS BLVD Southbound				Total	Rolling Hour
	U-Turn	Left	Thru	Right	U-Turn	Left	Thru	Right	U-Turn	Left	Thru	Right	U-Turn	Left	Thru	Right		
4:00 PM	0	0	0	0	0	14	0	60	0	0	50	10	0	30	20	0	184	691
4:15 PM	0	0	0	0	0	8	0	39	0	0	43	11	0	33	23	0	157	679
4:30 PM	0	0	0	0	0	7	0	58	0	0	44	8	0	35	18	0	170	662
4:45 PM	0	0	0	0	0	9	0	52	0	0	46	15	0	39	19	0	180	661
5:00 PM	0	0	0	0	0	8	0	67	0	0	44	8	0	27	18	0	172	655
5:15 PM	0	0	0	0	0	5	0	41	1	0	30	9	0	28	26	0	140	
5:30 PM	0	0	0	0	0	11	0	56	0	0	26	12	0	38	26	0	169	
5:45 PM	0	0	0	0	0	8	0	56	0	0	34	7	0	39	30	0	174	
Count Total	0	0	0	0	0	70	0	429	1	0	317	80	0	269	180	0	1,346	
Peak Hour	0	0	0	0	0	38	0	209	0	0	183	44	0	137	80	0	691	

Traffic Counts - Heavy Vehicles, Bicycles on Road, and Pedestrians/Bicycles in Crosswalk

Interval Start Time	Heavy Vehicles					Interval Start Time	Bicycles on Roadway					Interval Start Time	Pedestrians/Bicycles on Crosswalk				
	EB	NB	WB	SB	Total		EB	NB	WB	SB	Total		EB	NB	WB	SB	Total
4:00 PM	0	1	1	0	2	4:00 PM	0	0	0	0	0	4:00 PM	0	1	2	0	3
4:15 PM	0	0	1	5	6	4:15 PM	0	0	2	0	2	4:15 PM	0	0	0	2	2
4:30 PM	0	0	0	0	0	4:30 PM	0	0	0	0	0	4:30 PM	0	0	0	0	0
4:45 PM	0	1	2	0	3	4:45 PM	0	0	0	0	0	4:45 PM	2	2	0	0	4
5:00 PM	0	1	0	0	1	5:00 PM	0	0	0	0	0	5:00 PM	0	0	0	0	0
5:15 PM	0	0	0	0	0	5:15 PM	0	0	0	0	0	5:15 PM	0	0	1	0	1
5:30 PM	0	0	0	0	0	5:30 PM	0	0	0	0	0	5:30 PM	0	2	0	0	2
5:45 PM	0	1	0	0	1	5:45 PM	0	0	0	0	0	5:45 PM	0	0	1	0	1
Count Total	0	4	4	5	13	Count Total	0	0	2	0	2	Count Total	2	5	4	2	13
Peak Hour	0	2	4	5	11	Peak Hour	0	0	2	0	2	Peak Hour	2	3	2	2	9

Peak Hour

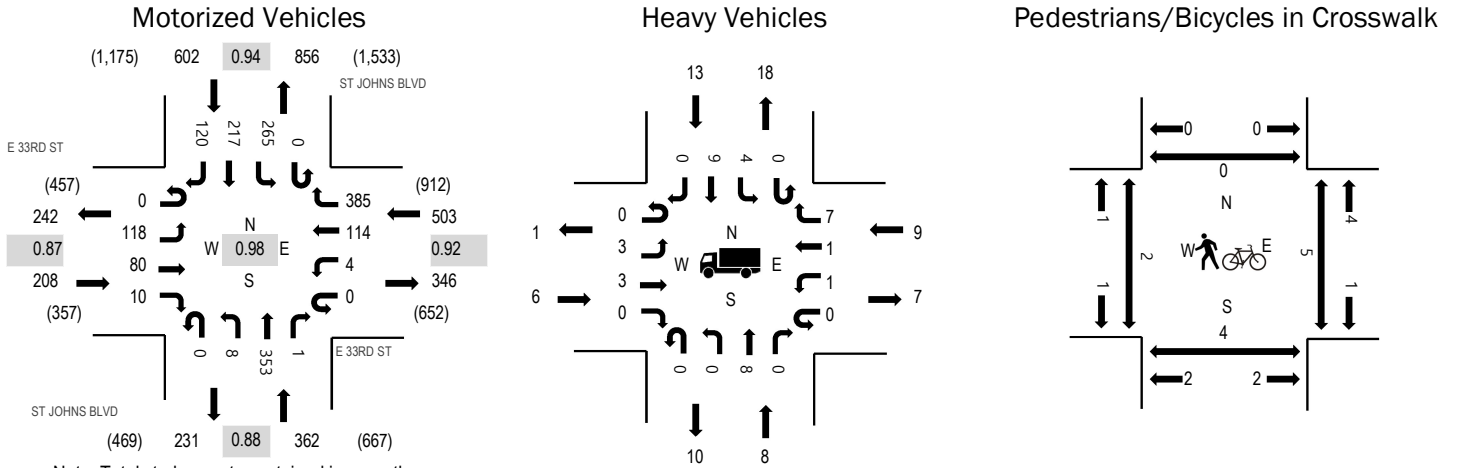

Note: Total study counts contained in parentheses.

	HV%	PHF
EB	2.9%	0.87
WB	1.8%	0.92
NB	2.2%	0.88
SB	2.2%	0.94
All	2.1%	0.98

Traffic Counts - Motorized Vehicles

Interval Start Time	E 33RD ST Eastbound				E 33RD ST Westbound				ST JOHNS BLVD Northbound				ST JOHNS BLVD Southbound				Total	Rolling Hour
	U-Turn	Left	Thru	Right	U-Turn	Left	Thru	Right	U-Turn	Left	Thru	Right	U-Turn	Left	Thru	Right		
4:00 PM	0	30	25	5	0	3	20	98	0	1	102	0	0	63	47	32	426	1,675
4:15 PM	0	28	22	0	0	1	39	88	0	3	75	0	0	60	62	30	408	1,652
4:30 PM	0	36	11	3	0	0	27	110	0	4	86	1	0	65	55	28	426	1,590
4:45 PM	0	24	22	2	0	0	28	89	0	0	90	0	0	77	53	30	415	1,508
5:00 PM	0	13	29	2	0	0	33	84	0	3	96	0	0	63	48	32	403	1,436
5:15 PM	0	18	17	4	0	1	26	81	0	1	65	0	0	58	50	25	346	
5:30 PM	0	27	9	4	0	0	23	75	0	2	65	1	0	59	55	24	344	
5:45 PM	0	16	9	1	0	1	18	67	0	0	70	2	0	59	72	28	343	
Count Total	0	192	144	21	0	6	214	692	0	14	649	4	0	504	442	229	3,111	
Peak Hour	0	118	80	10	0	4	114	385	0	8	353	1	0	265	217	120	1,675	

Traffic Counts - Heavy Vehicles, Bicycles on Road, and Pedestrians/Bicycles in Crosswalk

Interval Start Time	Heavy Vehicles					Interval Start Time	Bicycles on Roadway					Interval Start Time	Pedestrians/Bicycles on Crosswalk				
	EB	NB	WB	SB	Total		EB	NB	WB	SB	Total		EB	NB	WB	SB	Total
4:00 PM	1	1	1	2	5	4:00 PM	0	0	0	0	0	4:00 PM	0	1	2	0	3
4:15 PM	1	1	1	7	10	4:15 PM	0	2	0	0	2	4:15 PM	1	2	1	0	4
4:30 PM	4	2	7	2	15	4:30 PM	0	0	0	0	0	4:30 PM	1	1	0	0	2
4:45 PM	0	4	0	2	6	4:45 PM	0	1	0	0	1	4:45 PM	0	0	2	0	2
5:00 PM	0	4	1	2	7	5:00 PM	0	0	0	0	0	5:00 PM	0	2	1	0	3
5:15 PM	0	1	1	0	2	5:15 PM	1	0	1	2	4	5:15 PM	0	0	0	0	0
5:30 PM	0	1	0	1	2	5:30 PM	0	0	0	0	0	5:30 PM	0	1	2	0	3
5:45 PM	0	0	1	0	1	5:45 PM	0	0	0	0	0	5:45 PM	0	0	0	0	0
Count Total	6	14	12	16	48	Count Total	1	3	1	2	7	Count Total	2	7	8	0	17
Peak Hour	6	8	9	13	36	Peak Hour	0	3	0	0	3	Peak Hour	2	4	5	0	11

Peak Hour

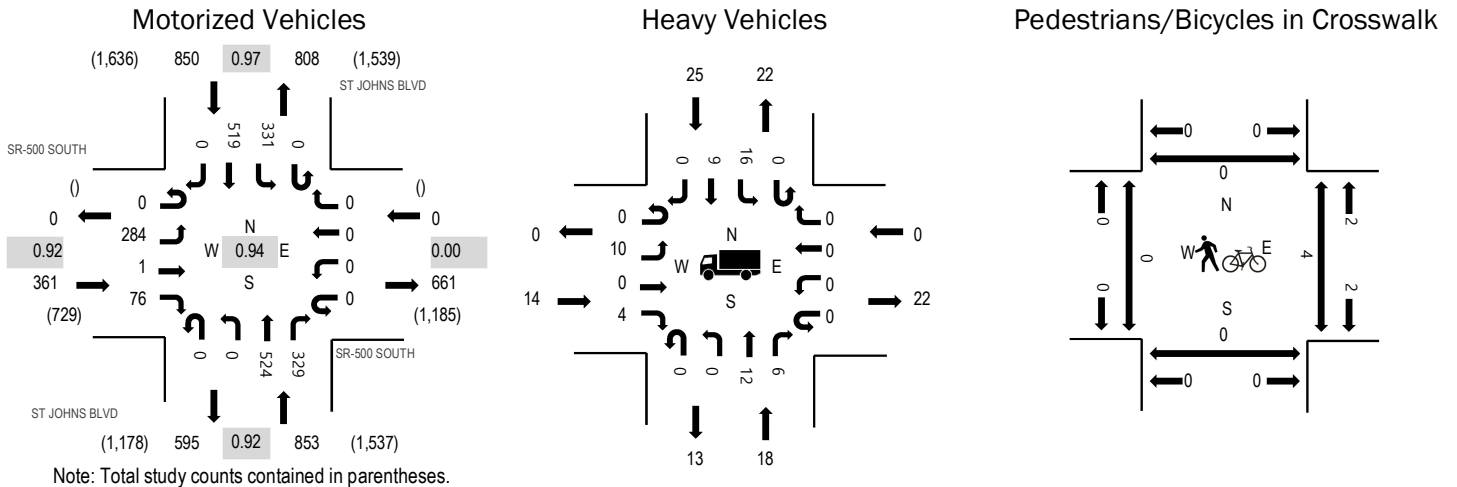

	HV%	PHF
EB	3.9%	0.92
WB	0.0%	0.00
NB	2.1%	0.92
SB	2.9%	0.97
All	2.8%	0.94

Traffic Counts - Motorized Vehicles

Interval Start Time	SR-500 SOUTH Eastbound				SR-500 SOUTH Westbound				ST JOHNS BLVD Northbound				ST JOHNS BLVD Southbound				Total	Rolling Hour
	U-Turn	Left	Thru	Right	U-Turn	Left	Thru	Right	U-Turn	Left	Thru	Right	U-Turn	Left	Thru	Right		
4:00 PM	0	75	1	24	0	0	0	0	0	0	145	83	0	97	122	0	547	2,064
4:15 PM	0	78	0	21	0	0	0	0	0	0	117	70	0	87	131	0	504	1,982
4:30 PM	0	70	0	15	0	0	0	0	0	0	137	94	0	76	121	0	513	1,952
4:45 PM	0	61	0	16	0	0	0	0	0	0	125	82	0	71	145	0	500	1,895
5:00 PM	0	67	0	14	0	0	0	0	0	0	103	74	0	75	132	0	465	1,838
5:15 PM	0	78	0	13	0	0	0	0	0	0	122	61	0	83	117	0	474	
5:30 PM	0	75	1	24	0	0	0	0	0	0	106	58	0	61	131	0	456	
5:45 PM	0	79	1	16	0	0	0	0	1	0	101	58	0	52	135	0	443	
Count Total	0	583	3	143	0	0	0	0	1	0	956	580	0	602	1,034	0	3,902	
Peak Hour	0	284	1	76	0	0	0	0	0	0	524	329	0	331	519	0	2,064	

Traffic Counts - Heavy Vehicles, Bicycles on Road, and Pedestrians/Bicycles in Crosswalk

Interval Start Time	Heavy Vehicles					Interval Start Time	Bicycles on Roadway					Interval Start Time	Pedestrians/Bicycles on Crosswalk				
	EB	NB	WB	SB	Total		EB	NB	WB	SB	Total		EB	NB	WB	SB	Total
4:00 PM	6	1	0	3	10	4:00 PM	0	0	0	0	0	4:00 PM	0	0	1	0	1
4:15 PM	6	1	0	13	20	4:15 PM	0	2	0	0	2	4:15 PM	0	0	0	0	0
4:30 PM	0	12	0	3	15	4:30 PM	0	0	0	0	0	4:30 PM	0	0	1	0	1
4:45 PM	2	4	0	6	12	4:45 PM	0	1	0	0	1	4:45 PM	0	0	2	0	2
5:00 PM	1	5	0	4	10	5:00 PM	0	0	0	0	0	5:00 PM	0	0	0	0	0
5:15 PM	0	1	0	0	1	5:15 PM	0	1	0	2	3	5:15 PM	2	0	3	0	5
5:30 PM	1	2	0	1	4	5:30 PM	0	0	0	0	0	5:30 PM	0	0	1	0	1
5:45 PM	0	1	0	0	1	5:45 PM	0	0	0	0	0	5:45 PM	0	0	3	0	3
Count Total	16	27	0	30	73	Count Total	0	4	0	2	6	Count Total	2	0	11	0	13
Peak Hour	14	18	0	25	57	Peak Hour	0	3	0	0	3	Peak Hour	0	0	4	0	4

Peak Hour

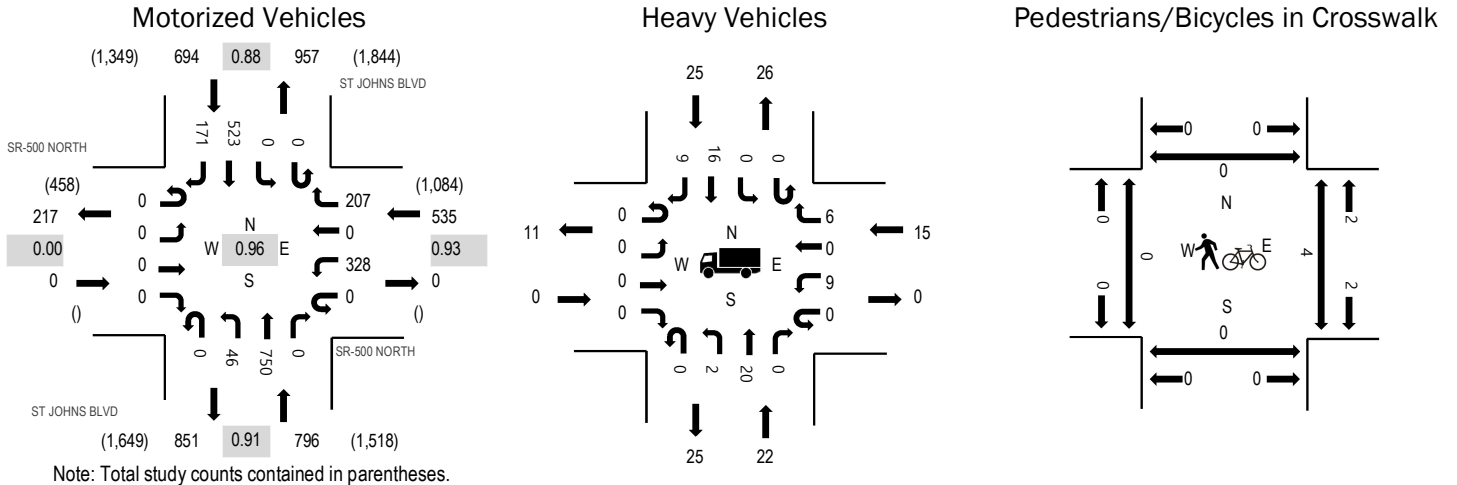

	HV%	PHF
EB	0.0%	0.00
WB	2.8%	0.93
NB	2.8%	0.91
SB	3.6%	0.88
All	3.1%	0.96

Traffic Counts - Motorized Vehicles

Interval Start Time	SR-500 NORTH Eastbound				SR-500 NORTH Westbound				ST JOHNS BLVD Northbound				ST JOHNS BLVD Southbound				Total	Rolling Hour
	U-Turn	Left	Thru	Right	U-Turn	Left	Thru	Right	U-Turn	Left	Thru	Right	U-Turn	Left	Thru	Right		
4:00 PM	0	0	0	0	0	66	0	44	0	11	208	0	0	0	151	46	526	2,025
4:15 PM	0	0	0	0	0	79	0	54	0	10	180	0	0	0	138	46	507	1,984
4:30 PM	0	0	0	0	0	90	0	53	0	12	194	0	0	0	107	44	500	1,978
4:45 PM	0	0	0	0	0	93	0	56	0	13	168	0	0	0	127	35	492	1,952
5:00 PM	0	0	0	0	0	78	0	53	0	9	158	0	0	0	131	56	485	1,926
5:15 PM	0	0	0	0	0	67	0	54	0	16	187	0	0	0	129	48	501	
5:30 PM	0	0	0	0	0	83	0	63	0	16	161	0	0	0	109	42	474	
5:45 PM	0	0	0	0	0	106	0	45	0	9	166	0	0	0	95	45	466	
Count Total	0	0	0	0	0	662	0	422	0	96	1,422	0	0	0	987	362	3,951	
Peak Hour	0	0	0	0	0	328	0	207	0	46	750	0	0	0	523	171	2,025	

Traffic Counts - Heavy Vehicles, Bicycles on Road, and Pedestrians/Bicycles in Crosswalk

Interval Start Time	Heavy Vehicles					Interval Start Time	Bicycles on Roadway					Interval Start Time	Pedestrians/Bicycles on Crosswalk				
	EB	NB	WB	SB	Total		EB	NB	WB	SB	Total		EB	NB	WB	SB	Total
4:00 PM	0	5	3	2	10	4:00 PM	0	0	0	0	0	4:00 PM	0	0	1	0	1
4:15 PM	0	5	6	12	23	4:15 PM	0	2	0	0	2	4:15 PM	0	0	0	0	0
4:30 PM	0	7	2	4	13	4:30 PM	0	0	0	0	0	4:30 PM	0	0	1	0	1
4:45 PM	0	5	4	7	16	4:45 PM	0	1	0	0	1	4:45 PM	0	0	2	0	2
5:00 PM	0	4	3	2	9	5:00 PM	0	0	0	0	0	5:00 PM	0	0	0	0	0
5:15 PM	0	1	3	1	5	5:15 PM	0	1	0	2	3	5:15 PM	0	0	2	0	2
5:30 PM	0	3	5	3	11	5:30 PM	0	0	0	0	0	5:30 PM	0	0	1	0	1
5:45 PM	0	1	0	2	3	5:45 PM	0	0	0	0	0	5:45 PM	0	0	2	0	2
Count Total	0	31	26	33	90	Count Total	0	4	0	2	6	Count Total	0	0	9	0	9
Peak Hour	0	22	15	25	62	Peak Hour	0	3	0	0	3	Peak Hour	0	0	4	0	4

Peak Hour

Motorized Vehicles

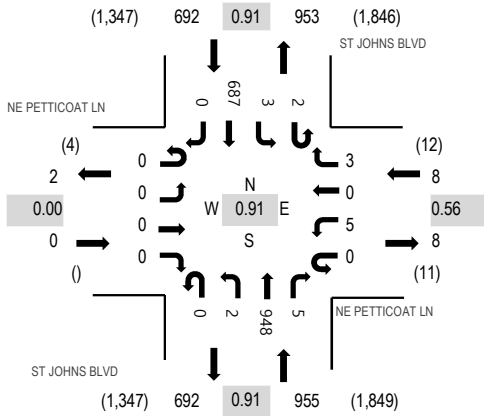

Heavy Vehicles

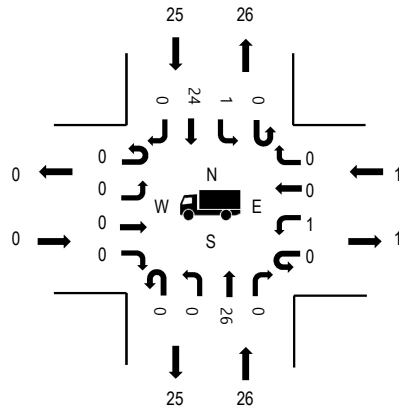

Pedestrians/Bicycles in Crosswalk

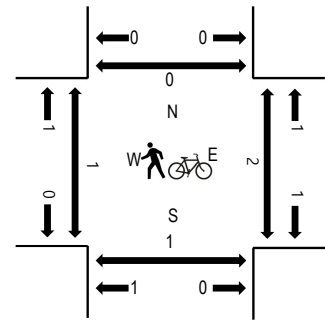

Note: Total study counts contained in parentheses.

	HV%	PHF
EB	0.0%	0.00
WB	12.5%	0.56
NB	2.7%	0.91
SB	3.6%	0.91
All	3.1%	0.91

Traffic Counts - Motorized Vehicles

Interval Start Time	NE PETTICOAT LN Eastbound				NE PETTICOAT LN Westbound				ST JOHNS BLVD Northbound				ST JOHNS BLVD Southbound				Total	Rolling Hour
	U-Turn	Left	Thru	Right	U-Turn	Left	Thru	Right	U-Turn	Left	Thru	Right	U-Turn	Left	Thru	Right		
4:00 PM	0	0	0	0	0	1	0	0	0	0	263	0	1	0	189	0	454	1,655
4:15 PM	0	0	0	0	0	2	0	2	0	1	223	2	1	1	182	0	414	1,622
4:30 PM	0	0	0	0	0	2	0	0	0	1	231	1	0	2	157	0	394	1,611
4:45 PM	0	0	0	0	0	0	0	1	0	0	231	2	0	0	159	0	393	1,586
5:00 PM	0	0	0	0	0	0	0	2	0	0	237	0	0	1	181	0	421	1,553
5:15 PM	0	0	0	0	0	1	0	0	0	1	226	1	0	0	174	0	403	
5:30 PM	0	0	0	0	0	0	0	0	0	0	221	0	0	1	147	0	369	
5:45 PM	0	0	0	0	0	0	0	1	1	1	206	0	0	0	151	0	360	
Count Total	0	0	0	0	0	6	0	6	1	4	1,838	6	2	5	1,340	0	3,208	
Peak Hour	0	0	0	0	0	5	0	3	0	2	948	5	2	3	687	0	1,655	

Traffic Counts - Heavy Vehicles, Bicycles on Road, and Pedestrians/Bicycles in Crosswalk

Interval Start Time	Heavy Vehicles					Interval Start Time	Bicycles on Roadway					Interval Start Time	Pedestrians/Bicycles on Crosswalk				
	EB	NB	WB	SB	Total		EB	NB	WB	SB	Total		EB	NB	WB	SB	Total
4:00 PM	0	6	0	2	8	4:00 PM	0	0	0	0	0	4:00 PM	1	1	0	0	2
4:15 PM	0	7	0	12	19	4:15 PM	0	2	0	0	2	4:15 PM	0	0	0	0	0
4:30 PM	0	5	1	4	10	4:30 PM	0	0	0	0	0	4:30 PM	0	0	1	0	1
4:45 PM	0	8	0	7	15	4:45 PM	0	1	0	0	1	4:45 PM	0	0	1	0	1
5:00 PM	0	5	0	2	7	5:00 PM	0	0	0	0	0	5:00 PM	0	0	0	0	0
5:15 PM	0	4	0	1	5	5:15 PM	0	1	0	2	3	5:15 PM	1	1	2	0	4
5:30 PM	0	8	0	3	11	5:30 PM	0	0	0	0	0	5:30 PM	0	0	1	0	1
5:45 PM	0	1	0	2	3	5:45 PM	0	0	0	0	0	5:45 PM	1	1	2	0	4
Count Total	0	44	1	33	78	Count Total	0	4	0	2	6	Count Total	3	3	7	0	13
Peak Hour	0	26	1	25	52	Peak Hour	0	3	0	0	3	Peak Hour	1	1	2	0	4

Peak Hour

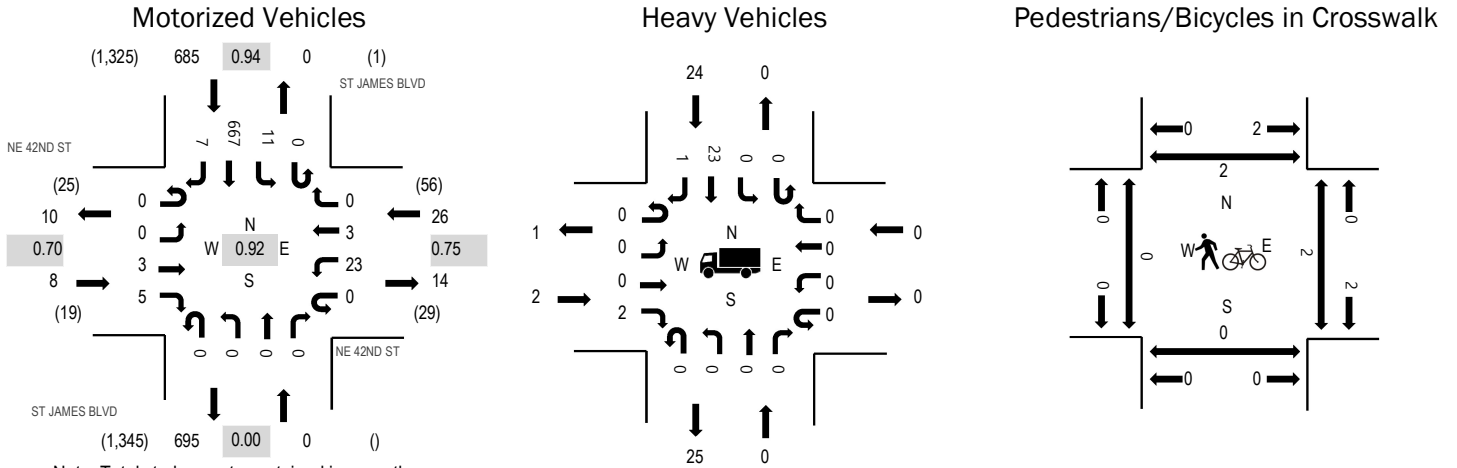

Note: Total study counts contained in parentheses.

	HV%	PHF
EB	25.0%	0.70
WB	0.0%	0.75
NB	0.0%	0.00
SB	3.5%	0.94
All	3.6%	0.92

Traffic Counts - Motorized Vehicles

Interval Start Time	NE 42ND ST Eastbound				NE 42ND ST Westbound				ST JAMES BLVD Northbound				ST JAMES BLVD Southbound				Total	Rolling Hour
	U-Turn	Left	Thru	Right	U-Turn	Left	Thru	Right	U-Turn	Left	Thru	Right	U-Turn	Left	Thru	Right		
4:00 PM	0	0	2	1	0	10	1	0	0	0	0	0	0	3	177	1	195	719
4:15 PM	0	0	0	1	0	7	2	0	0	0	0	0	0	2	176	2	190	719
4:30 PM	0	0	1	3	0	2	0	0	0	0	0	0	0	4	155	2	167	707
4:45 PM	0	0	0	0	0	4	0	0	0	0	0	0	0	2	159	2	167	692
5:00 PM	0	0	2	3	0	6	2	0	0	0	0	0	1	6	174	1	195	681
5:15 PM	0	0	0	5	0	3	2	0	0	0	0	0	0	5	162	1	178	
5:30 PM	0	0	0	1	0	3	4	0	0	0	0	0	0	1	143	0	152	
5:45 PM	0	0	0	0	0	7	3	0	0	0	0	0	0	1	143	2	156	
Count Total	0	0	5	14	0	42	14	0	0	0	0	0	1	24	1,289	11	1,400	
Peak Hour	0	0	3	5	0	23	3	0	0	0	0	0	0	11	667	7	719	

Traffic Counts - Heavy Vehicles, Bicycles on Road, and Pedestrians/Bicycles in Crosswalk

Interval Start Time	Heavy Vehicles					Interval Start Time	Bicycles on Roadway					Interval Start Time	Pedestrians/Bicycles on Crosswalk				
	EB	NB	WB	SB	Total		EB	NB	WB	SB	Total		EB	NB	WB	SB	Total
4:00 PM	0	0	0	2	2	4:00 PM	0	0	0	0	0	4:00 PM	0	0	0	0	0
4:15 PM	0	0	0	13	13	4:15 PM	1	0	0	0	1	4:15 PM	0	0	2	0	2
4:30 PM	2	0	0	2	4	4:30 PM	0	0	0	0	0	4:30 PM	0	0	0	0	0
4:45 PM	0	0	0	7	7	4:45 PM	0	0	0	0	0	4:45 PM	0	0	0	2	2
5:00 PM	0	0	0	2	2	5:00 PM	0	0	0	0	0	5:00 PM	0	0	0	0	0
5:15 PM	0	0	0	1	1	5:15 PM	0	0	0	2	2	5:15 PM	0	0	0	0	0
5:30 PM	0	0	0	3	3	5:30 PM	0	0	0	0	0	5:30 PM	0	0	0	0	0
5:45 PM	0	0	0	2	2	5:45 PM	0	0	0	0	0	5:45 PM	1	0	0	1	2
Count Total	2	0	0	32	34	Count Total	1	0	0	2	3	Count Total	1	0	2	3	6
Peak Hour	2	0	0	24	26	Peak Hour	1	0	0	0	1	Peak Hour	0	0	2	2	4

Peak Hour

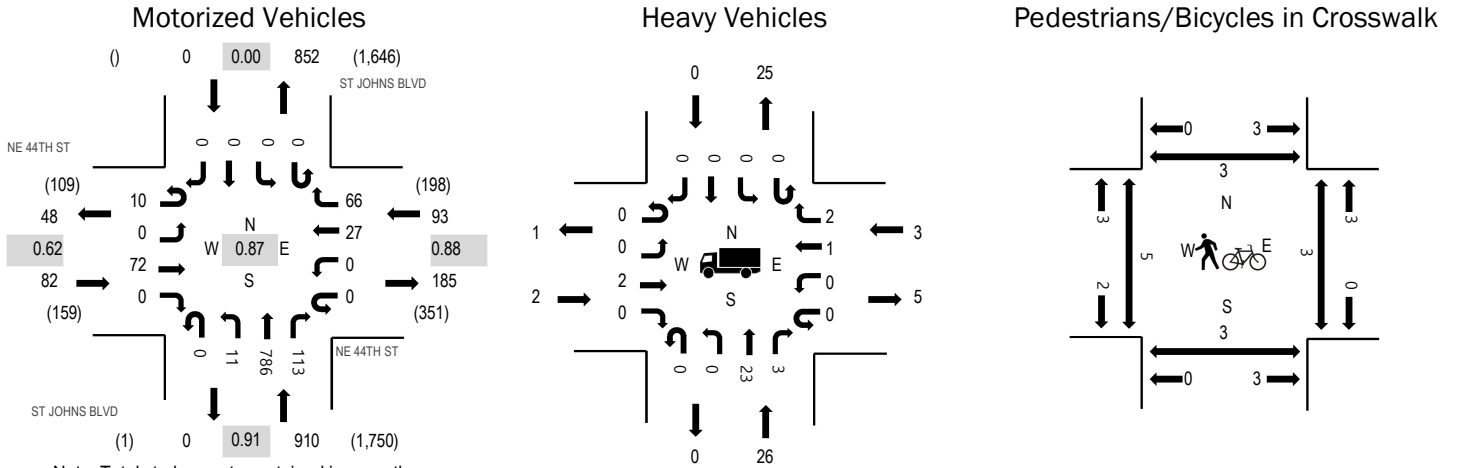

Note: Total study counts contained in parentheses.

	HV%	PHF
EB	2.4%	0.62
WB	3.2%	0.88
NB	2.9%	0.91
SB	0.0%	0.00
All	2.9%	0.87

Traffic Counts - Motorized Vehicles

Interval Start Time	NE 44TH ST Eastbound				NE 44TH ST Westbound				ST JOHNS BLVD Northbound				ST JOHNS BLVD Southbound				Total	Rolling Hour
	U-Turn	Left	Thru	Right	U-Turn	Left	Thru	Right	U-Turn	Left	Thru	Right	U-Turn	Left	Thru	Right		
4:00 PM	0	0	33	0	0	0	5	23	0	3	215	32	0	0	0	0	311	1,085
4:15 PM	3	0	14	0	0	0	10	16	0	5	183	27	0	0	0	0	258	1,040
4:30 PM	3	0	13	0	0	0	8	11	0	1	183	33	0	0	0	0	252	1,039
4:45 PM	4	0	12	0	0	0	4	16	0	2	205	21	0	0	0	0	264	1,043
5:00 PM	1	0	20	0	0	0	6	11	0	4	203	21	0	0	0	0	266	1,022
5:15 PM	1	0	18	0	0	0	14	16	0	4	178	26	0	0	0	0	257	
5:30 PM	2	0	16	0	0	0	9	19	0	2	186	22	0	0	0	0	256	
5:45 PM	1	0	17	1	0	0	11	19	0	6	162	26	0	0	0	0	243	
Count Total	15	0	143	1	0	0	67	131	0	27	1,515	208	0	0	0	0	2,107	
Peak Hour	10	0	72	0	0	0	27	66	0	11	786	113	0	0	0	0	1,085	

Traffic Counts - Heavy Vehicles, Bicycles on Road, and Pedestrians/Bicycles in Crosswalk

Interval Start Time	Heavy Vehicles					Interval Start Time	Bicycles on Roadway					Interval Start Time	Pedestrians/Bicycles on Crosswalk				
	EB	NB	WB	SB	Total		EB	NB	WB	SB	Total		EB	NB	WB	SB	Total
4:00 PM	1	6	0	0	7	4:00 PM	0	0	0	0	0	4:00 PM	0	0	0	0	0
4:15 PM	1	7	2	0	10	4:15 PM	0	2	0	0	2	4:15 PM	3	0	1	0	4
4:30 PM	0	5	1	0	6	4:30 PM	0	0	0	0	0	4:30 PM	2	1	0	1	4
4:45 PM	0	8	0	0	8	4:45 PM	0	3	0	0	3	4:45 PM	0	2	2	2	6
5:00 PM	1	5	0	0	6	5:00 PM	0	0	0	1	1	5:00 PM	0	0	0	0	0
5:15 PM	0	4	1	0	5	5:15 PM	0	1	0	0	1	5:15 PM	0	0	0	0	0
5:30 PM	0	8	1	0	9	5:30 PM	0	0	0	0	0	5:30 PM	0	0	1	0	1
5:45 PM	0	1	1	0	2	5:45 PM	0	0	0	0	0	5:45 PM	0	0	1	0	1
Count Total	3	44	6	0	53	Count Total	0	6	0	1	7	Count Total	5	3	5	3	16
Peak Hour	2	26	3	0	31	Peak Hour	0	5	0	0	5	Peak Hour	5	3	3	3	14

Peak Hour

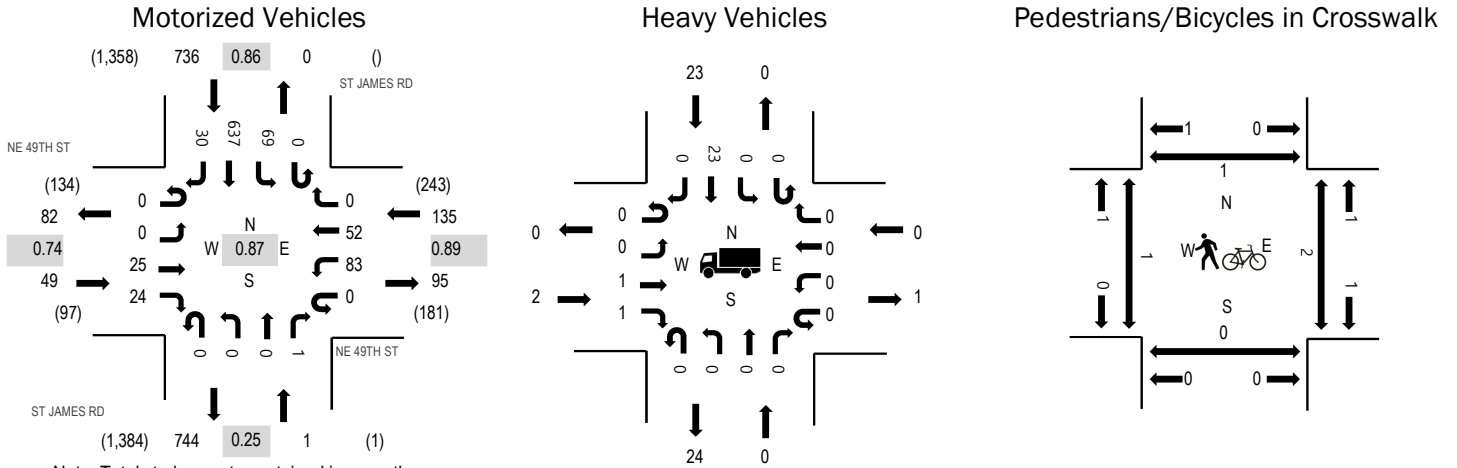

Note: Total study counts contained in parentheses.

	HV%	PHF
EB	4.1%	0.74
WB	0.0%	0.89
NB	0.0%	0.25
SB	3.1%	0.86
All	2.7%	0.87

Traffic Counts - Motorized Vehicles

Interval Start Time	NE 49TH ST Eastbound				NE 49TH ST Westbound				ST JAMES RD Northbound				ST JAMES RD Southbound				Total	Rolling Hour
	U-Turn	Left	Thru	Right	U-Turn	Left	Thru	Right	U-Turn	Left	Thru	Right	U-Turn	Left	Thru	Right		
4:00 PM	0	0	5	7	0	24	14	0	0	0	0	0	0	25	179	10	264	921
4:15 PM	0	0	6	6	0	19	13	0	0	0	0	1	0	15	162	7	229	891
4:30 PM	0	0	7	6	0	19	19	0	0	0	0	0	0	13	155	9	228	866
4:45 PM	0	0	7	5	0	21	6	0	0	0	0	0	0	16	141	4	200	810
5:00 PM	0	0	8	11	0	14	9	0	0	0	0	0	0	23	164	5	234	778
5:15 PM	0	0	2	7	0	17	8	0	0	0	0	0	0	21	144	5	204	
5:30 PM	0	0	3	5	0	28	10	0	0	0	0	0	0	10	113	3	172	
5:45 PM	0	0	6	6	1	13	8	0	0	0	0	0	0	12	118	4	168	
Count Total	0	0	44	53	1	155	87	0	0	0	0	1	0	135	1,176	47	1,699	
Peak Hour	0	0	25	24	0	83	52	0	0	0	0	1	0	69	637	30	921	

Traffic Counts - Heavy Vehicles, Bicycles on Road, and Pedestrians/Bicycles in Crosswalk

Interval Start Time	Heavy Vehicles					Interval Start Time	Bicycles on Roadway					Interval Start Time	Pedestrians/Bicycles on Crosswalk				
	EB	NB	WB	SB	Total		EB	NB	WB	SB	Total		EB	NB	WB	SB	Total
4:00 PM	0	0	0	2	2	4:00 PM	0	0	0	0	0	4:00 PM	1	0	0	0	1
4:15 PM	1	0	0	12	13	4:15 PM	0	0	0	1	1	4:15 PM	0	0	0	0	0
4:30 PM	1	0	0	2	3	4:30 PM	0	0	0	0	0	4:30 PM	0	0	2	1	3
4:45 PM	0	0	0	7	7	4:45 PM	0	0	0	0	0	4:45 PM	0	0	0	0	0
5:00 PM	0	0	0	2	2	5:00 PM	0	0	0	1	1	5:00 PM	2	0	0	0	2
5:15 PM	0	0	0	1	1	5:15 PM	0	0	0	1	1	5:15 PM	0	0	0	0	0
5:30 PM	0	0	0	3	3	5:30 PM	0	0	0	0	0	5:30 PM	0	0	0	0	0
5:45 PM	0	0	0	3	3	5:45 PM	0	0	0	0	0	5:45 PM	1	0	0	0	1
Count Total	2	0	0	32	34	Count Total	0	0	0	3	3	Count Total	4	0	2	1	7
Peak Hour	2	0	0	23	25	Peak Hour	0	0	0	1	1	Peak Hour	1	0	2	1	4

Peak Hour

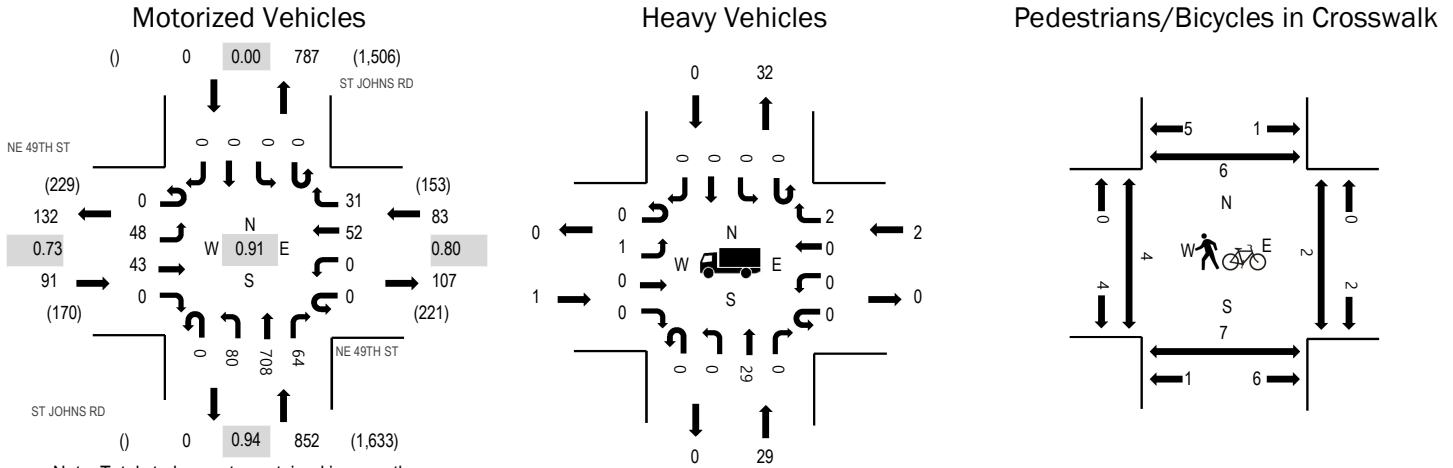

Note: Total study counts contained in parentheses.

	HV%	PHF
EB	1.1%	0.73
WB	2.4%	0.80
NB	3.4%	0.94
SB	0.0%	0.00
All	3.1%	0.91

Traffic Counts - Motorized Vehicles

Interval Start Time	NE 49TH ST Eastbound				NE 49TH ST Westbound				ST JOHNS RD Northbound			ST JOHNS RD Southbound				Total	Rolling Hour	
	U-Turn	Left	Thru	Right	U-Turn	Left	Thru	Right	U-Turn	Left	Thru	Right	U-Turn	Left	Thru			Right
4:00 PM	0	15	16	0	0	0	17	6	0	22	190	15	0	0	0	0	281	1,026
4:15 PM	0	12	11	0	0	0	14	12	0	19	172	22	0	0	0	0	262	993
4:30 PM	0	11	8	0	0	0	9	8	0	28	169	11	0	0	0	0	244	975
4:45 PM	0	10	8	0	0	0	12	5	0	11	177	16	0	0	0	0	239	964
5:00 PM	0	16	11	0	0	0	7	6	0	15	178	15	0	0	0	0	248	930
5:15 PM	0	13	7	0	0	0	7	5	0	14	176	22	0	0	0	0	244	
5:30 PM	0	9	4	0	0	0	15	9	0	16	158	22	0	0	0	0	233	
5:45 PM	0	11	8	0	0	0	16	5	0	7	133	25	0	0	0	0	205	
Count Total	0	97	73	0	0	0	97	56	0	132	1,353	148	0	0	0	0	1,956	
Peak Hour	0	48	43	0	0	0	52	31	0	80	708	64	0	0	0	0	1,026	

Traffic Counts - Heavy Vehicles, Bicycles on Road, and Pedestrians/Bicycles in Crosswalk

Interval Start Time	Heavy Vehicles					Interval Start Time	Bicycles on Roadway					Interval Start Time	Pedestrians/Bicycles on Crosswalk				
	EB	NB	WB	SB	Total		EB	NB	WB	SB	Total		EB	NB	WB	SB	Total
4:00 PM	0	6	0	0	6	4:00 PM	0	1	0	0	1	4:00 PM	0	0	0	0	0
4:15 PM	0	9	2	0	11	4:15 PM	0	1	0	0	1	4:15 PM	1	0	0	0	2
4:30 PM	1	6	0	0	7	4:30 PM	0	0	0	0	0	4:30 PM	3	7	0	0	10
4:45 PM	0	8	0	0	8	4:45 PM	0	0	0	0	0	4:45 PM	0	0	2	0	2
5:00 PM	0	6	0	0	6	5:00 PM	0	1	0	0	1	5:00 PM	0	1	2	0	3
5:15 PM	0	9	0	0	9	5:15 PM	0	1	0	0	1	5:15 PM	0	0	0	0	0
5:30 PM	0	6	0	0	6	5:30 PM	0	0	0	0	0	5:30 PM	0	2	2	0	4
5:45 PM	0	2	0	0	2	5:45 PM	0	0	0	0	0	5:45 PM	0	0	2	0	2
Count Total	1	52	2	0	55	Count Total	0	4	0	0	4	Count Total	4	10	8	0	22
Peak Hour	1	29	2	0	32	Peak Hour	0	2	0	0	2	Peak Hour	4	7	2	0	13

Peak Hour

Motorized Vehicles

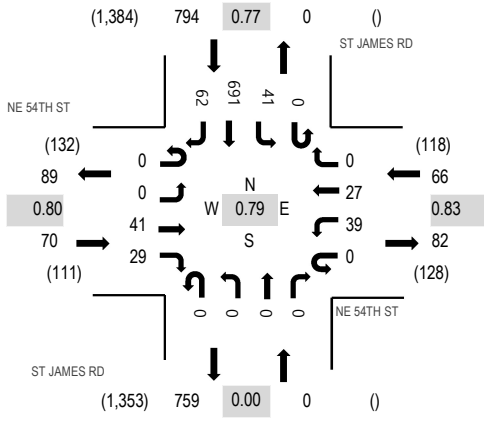

Heavy Vehicles

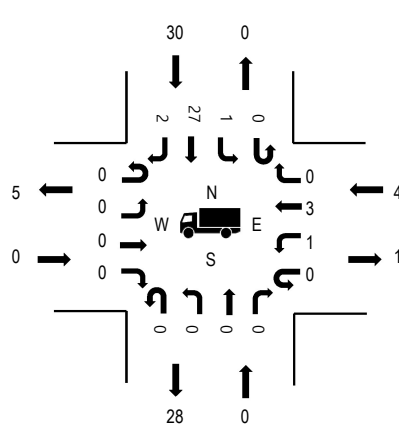

Pedestrians/Bicycles in Crosswalk

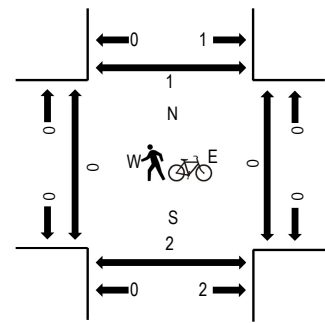

Note: Total study counts contained in parentheses.

	HV%	PHF
EB	0.0%	0.80
WB	6.1%	0.83
NB	0.0%	0.00
SB	3.8%	0.77
All	3.7%	0.79

Traffic Counts - Motorized Vehicles

Interval Start Time	NE 54TH ST Eastbound				NE 54TH ST Westbound				ST JAMES RD Northbound			ST JAMES RD Southbound				Total	Rolling Hour	
	U-Turn	Left	Thru	Right	U-Turn	Left	Thru	Right	U-Turn	Left	Thru	Right	U-Turn	Left	Thru			Right
4:00 PM	0	0	15	7	0	12	3	0	0	0	0	0	0	10	223	26	296	930
4:15 PM	0	0	10	6	0	5	12	0	0	0	0	0	0	9	174	17	233	833
4:30 PM	0	0	7	8	0	14	6	0	0	0	0	0	0	12	166	14	227	770
4:45 PM	0	0	9	8	0	8	6	0	0	0	0	0	0	10	128	5	174	697
5:00 PM	0	0	4	5	0	8	5	0	0	0	0	0	0	4	170	3	199	683
5:15 PM	0	0	2	5	0	11	6	0	0	0	0	0	0	4	137	5	170	
5:30 PM	0	0	7	7	0	6	7	0	0	0	0	0	0	11	111	5	154	
5:45 PM	0	0	7	4	0	7	2	0	0	0	0	0	0	7	123	10	160	
Count Total	0	0	61	50	0	71	47	0	0	0	0	0	0	67	1,232	85	1,613	
Peak Hour	0	0	41	29	0	39	27	0	0	0	0	0	0	41	691	62	930	

Traffic Counts - Heavy Vehicles, Bicycles on Road, and Pedestrians/Bicycles in Crosswalk

Interval Start Time	Heavy Vehicles					Interval Start Time	Bicycles on Roadway					Interval Start Time	Pedestrians/Bicycles on Crosswalk				
	EB	NB	WB	SB	Total		EB	NB	WB	SB	Total		EB	NB	WB	SB	Total
4:00 PM	0	0	1	12	13	4:00 PM	0	0	0	0	0	4:00 PM	0	0	0	1	1
4:15 PM	0	0	1	10	11	4:15 PM	0	0	0	1	1	4:15 PM	0	1	0	0	1
4:30 PM	0	0	1	6	7	4:30 PM	0	0	0	0	0	4:30 PM	0	1	0	0	1
4:45 PM	0	0	1	2	3	4:45 PM	0	0	0	0	0	4:45 PM	0	0	0	0	0
5:00 PM	0	0	0	2	2	5:00 PM	0	0	0	1	1	5:00 PM	0	1	1	1	3
5:15 PM	0	0	0	1	1	5:15 PM	0	0	0	1	1	5:15 PM	0	0	0	0	0
5:30 PM	0	0	0	3	3	5:30 PM	0	0	0	0	0	5:30 PM	0	0	0	0	0
5:45 PM	0	0	1	4	5	5:45 PM	0	0	0	0	0	5:45 PM	0	0	0	0	0
Count Total	0	0	5	40	45	Count Total	0	0	0	3	3	Count Total	0	3	1	2	6
Peak Hour	0	0	4	30	34	Peak Hour	0	0	0	1	1	Peak Hour	0	2	0	1	3

Peak Hour

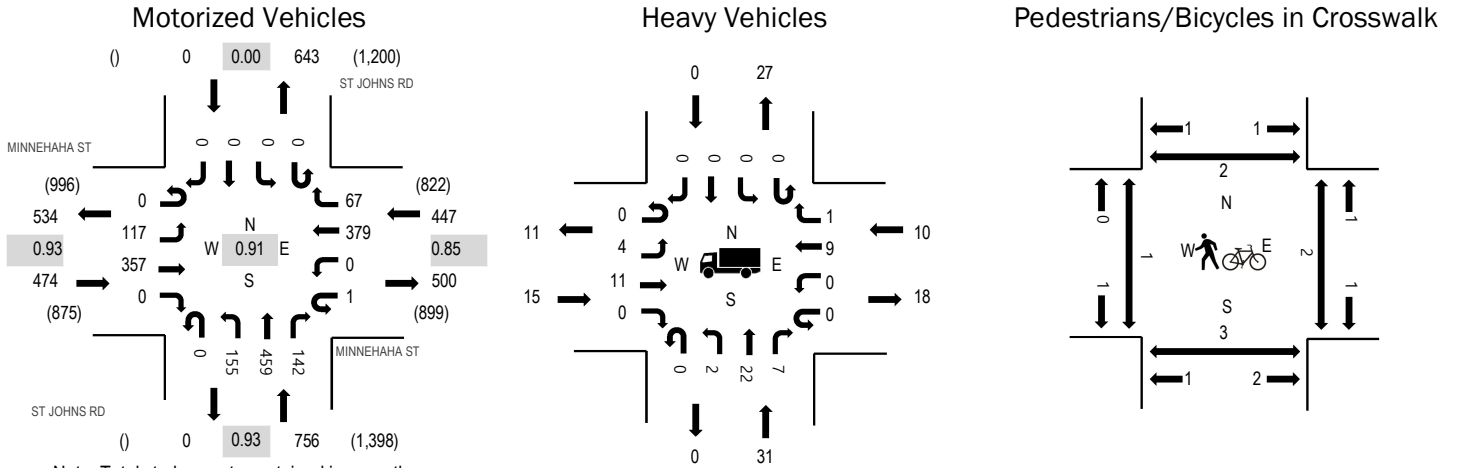

Note: Total study counts contained in parentheses.

	HV%	PHF
EB	3.2%	0.93
WB	2.2%	0.85
NB	4.1%	0.93
SB	0.0%	0.00
All	3.3%	0.91

Traffic Counts - Motorized Vehicles

Interval Start Time	MINNEHAHA ST Eastbound				MINNEHAHA ST Westbound				ST JOHNS RD Northbound				ST JOHNS RD Southbound				Total	Rolling Hour
	U-Turn	Left	Thru	Right	U-Turn	Left	Thru	Right	U-Turn	Left	Thru	Right	U-Turn	Left	Thru	Right		
4:00 PM	0	29	99	0	0	0	108	23	0	43	119	41	0	0	0	0	462	1,677
4:15 PM	0	24	92	0	1	0	96	15	0	35	114	31	0	0	0	0	408	1,613
4:30 PM	0	31	85	0	0	0	82	11	0	46	112	38	0	0	0	0	405	1,554
4:45 PM	0	33	81	0	0	0	93	18	0	31	114	32	0	0	0	0	402	1,488
5:00 PM	0	29	75	0	0	0	98	17	0	39	115	25	0	0	0	0	398	1,418
5:15 PM	0	27	74	0	0	0	67	17	0	32	101	31	0	0	0	0	349	
5:30 PM	0	20	66	0	0	0	72	15	0	41	102	23	0	0	0	0	339	
5:45 PM	0	24	86	0	0	0	82	7	0	31	83	19	0	0	0	0	332	
Count Total	0	217	658	0	1	0	698	123	0	298	860	240	0	0	0	0	3,095	
Peak Hour	0	117	357	0	1	0	379	67	0	155	459	142	0	0	0	0	1,677	

Traffic Counts - Heavy Vehicles, Bicycles on Road, and Pedestrians/Bicycles in Crosswalk

Interval Start Time	Heavy Vehicles					Interval Start Time	Bicycles on Roadway					Interval Start Time	Pedestrians/Bicycles on Crosswalk				
	EB	NB	WB	SB	Total		EB	NB	WB	SB	Total		EB	NB	WB	SB	Total
4:00 PM	6	8	5	0	19	4:00 PM	0	1	0	0	1	4:00 PM	1	1	0	1	3
4:15 PM	6	7	3	0	16	4:15 PM	0	0	0	0	0	4:15 PM	0	1	0	1	2
4:30 PM	3	9	1	0	13	4:30 PM	0	0	0	0	0	4:30 PM	0	1	2	0	3
4:45 PM	0	7	1	0	8	4:45 PM	0	0	0	0	0	4:45 PM	0	0	0	0	0
5:00 PM	2	5	2	0	9	5:00 PM	0	0	0	0	0	5:00 PM	0	0	0	0	0
5:15 PM	5	2	1	0	8	5:15 PM	0	0	0	0	0	5:15 PM	0	0	0	0	0
5:30 PM	3	8	1	0	12	5:30 PM	0	0	0	0	0	5:30 PM	0	0	0	0	0
5:45 PM	2	0	2	0	4	5:45 PM	0	0	0	0	0	5:45 PM	0	0	0	0	0
Count Total	27	46	16	0	89	Count Total	0	1	0	0	1	Count Total	1	3	2	2	8
Peak Hour	15	31	10	0	56	Peak Hour	0	1	0	0	1	Peak Hour	1	3	2	2	8

Peak Hour

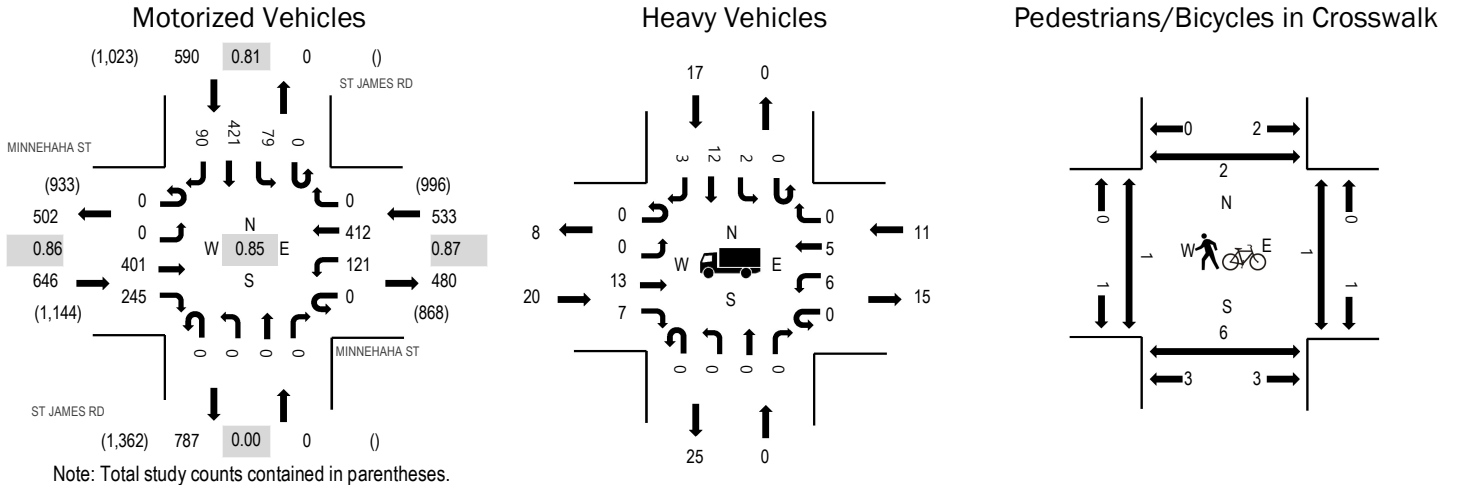

	HV%	PHF
EB	3.1%	0.86
WB	2.1%	0.87
NB	0.0%	0.00
SB	2.9%	0.81
All	2.7%	0.85

Traffic Counts - Motorized Vehicles

Interval Start Time	MINNEHAHA ST Eastbound				MINNEHAHA ST Westbound				ST JAMES RD Northbound				ST JAMES RD Southbound			Total	Rolling Hour	
	U-Turn	Left	Thru	Right	U-Turn	Left	Thru	Right	U-Turn	Left	Thru	Right	U-Turn	Left	Thru			Right
4:00 PM	0	0	105	83	0	31	122	0	0	0	0	0	0	22	138	21	522	1,769
4:15 PM	0	0	95	68	0	31	91	0	0	0	0	0	0	15	101	29	430	1,629
4:30 PM	0	0	105	55	0	34	108	0	0	0	0	0	0	21	83	23	429	1,530
4:45 PM	0	0	96	39	0	25	91	0	0	0	0	0	0	21	99	17	388	1,436
5:00 PM	0	0	83	45	0	38	94	0	0	0	0	0	0	10	88	24	382	1,394
5:15 PM	0	0	86	25	0	23	80	0	0	0	0	0	0	13	87	17	331	
5:30 PM	0	0	88	38	0	27	89	0	0	0	0	0	0	10	62	21	335	
5:45 PM	0	0	89	44	0	22	90	0	0	0	0	0	0	9	76	16	346	
Count Total	0	0	747	397	0	231	765	0	0	0	0	0	0	121	734	168	3,163	
Peak Hour	0	0	401	245	0	121	412	0	0	0	0	0	0	79	421	90	1,769	

Traffic Counts - Heavy Vehicles, Bicycles on Road, and Pedestrians/Bicycles in Crosswalk

Interval Start Time	Heavy Vehicles					Interval Start Time	Bicycles on Roadway					Interval Start Time	Pedestrians/Bicycles on Crosswalk				
	EB	NB	WB	SB	Total		EB	NB	WB	SB	Total		EB	NB	WB	SB	Total
4:00 PM	8	0	5	7	20	4:00 PM	0	0	0	0	0	4:00 PM	0	2	0	0	2
4:15 PM	10	0	2	4	16	4:15 PM	0	0	0	0	0	4:15 PM	0	2	1	2	5
4:30 PM	2	0	3	5	10	4:30 PM	0	0	0	0	0	4:30 PM	0	1	0	0	1
4:45 PM	0	0	1	1	2	4:45 PM	0	0	0	0	0	4:45 PM	1	1	0	0	2
5:00 PM	2	0	1	1	4	5:00 PM	0	0	0	0	0	5:00 PM	0	1	0	0	1
5:15 PM	4	0	0	1	5	5:15 PM	0	0	0	2	2	5:15 PM	0	0	0	0	0
5:30 PM	3	0	1	4	8	5:30 PM	0	0	0	0	0	5:30 PM	0	0	0	0	0
5:45 PM	2	0	1	5	8	5:45 PM	0	0	0	0	0	5:45 PM	0	0	0	0	0
Count Total	31	0	14	28	73	Count Total	0	0	0	2	2	Count Total	1	7	1	2	11
Peak Hour	20	0	11	17	48	Peak Hour	0	0	0	0	0	Peak Hour	1	6	1	2	10

Peak Hour

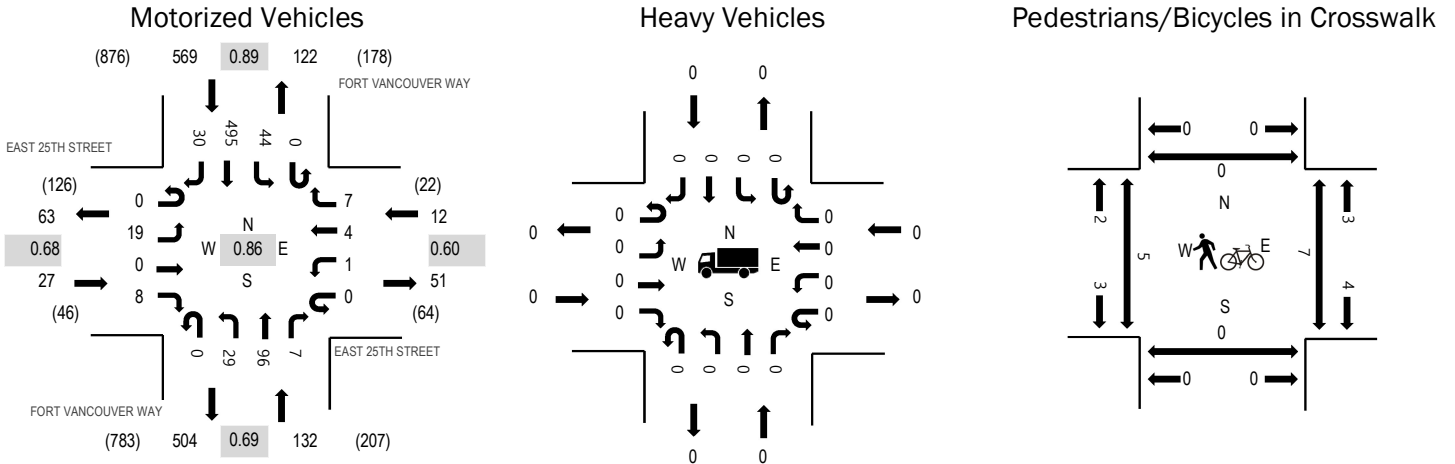

Note: Total study counts contained in parentheses.

	HV%	PHF
EB	0.0%	0.68
WB	0.0%	0.60
NB	0.0%	0.69
SB	0.0%	0.89
All	0.0%	0.86

Traffic Counts - Motorized Vehicles

Interval Start Time	EAST 25TH STREET Eastbound				EAST 25TH STREET Westbound				FORT VANCOUVER WAY Northbound				FORT VANCOUVER WAY Southbound				Total	Rolling Hour
	U-Turn	Left	Thru	Right	U-Turn	Left	Thru	Right	U-Turn	Left	Thru	Right	U-Turn	Left	Thru	Right		
6:30 AM	0	0	0	3	0	0	2	0	0	8	12	0	0	4	49	5	83	411
6:45 AM	0	2	0	0	0	0	0	2	0	8	12	0	0	2	70	8	104	488
7:00 AM	0	6	0	2	0	1	1	1	0	6	9	0	0	1	70	9	106	575
7:15 AM	0	1	2	3	0	2	0	1	0	9	10	1	0	3	79	7	118	643
7:30 AM	0	3	0	2	0	0	1	1	0	8	23	2	0	9	102	9	160	740
7:45 AM	0	8	0	3	0	0	1	1	0	4	19	2	0	13	133	7	191	
8:00 AM	0	4	0	2	0	1	2	2	0	6	18	2	0	16	115	6	174	
8:15 AM	0	4	0	1	0	0	0	3	0	11	36	1	0	6	145	8	215	
Count Total	0	28	2	16	0	4	7	11	0	60	139	8	0	54	763	59	1,151	
Peak Hour	0	19	0	8	0	1	4	7	0	29	96	7	0	44	495	30	740	

Traffic Counts - Heavy Vehicles, Bicycles on Road, and Pedestrians/Bicycles in Crosswalk

Interval Start Time	Heavy Vehicles					Interval Start Time	Bicycles on Roadway					Interval Start Time	Pedestrians/Bicycles on Crosswalk				
	EB	NB	WB	SB	Total		EB	NB	WB	SB	Total		EB	NB	WB	SB	Total
6:30 AM	0	0	0	0	0	6:30 AM	0	0	0	0	0	6:30 AM	0	0	1	0	1
6:45 AM	0	0	0	0	0	6:45 AM	0	0	0	0	0	6:45 AM	1	0	1	0	2
7:00 AM	0	1	0	0	1	7:00 AM	0	0	0	0	0	7:00 AM	2	0	0	0	2
7:15 AM	0	0	0	0	0	7:15 AM	0	0	0	0	0	7:15 AM	1	0	0	0	1
7:30 AM	0	0	0	0	0	7:30 AM	0	0	0	1	1	7:30 AM	1	0	3	0	4
7:45 AM	0	0	0	0	0	7:45 AM	0	0	0	0	0	7:45 AM	2	0	3	0	5
8:00 AM	0	0	0	0	0	8:00 AM	0	0	0	0	0	8:00 AM	0	0	0	0	0
8:15 AM	0	0	0	0	0	8:15 AM	0	0	0	0	0	8:15 AM	2	0	1	0	3
Count Total	0	1	0	0	1	Count Total	0	0	0	1	1	Count Total	9	0	9	0	18
Peak Hour	0	0	0	0	0	Peak Hour	0	0	0	1	1	Peak Hour	5	0	7	0	12

Peak Hour

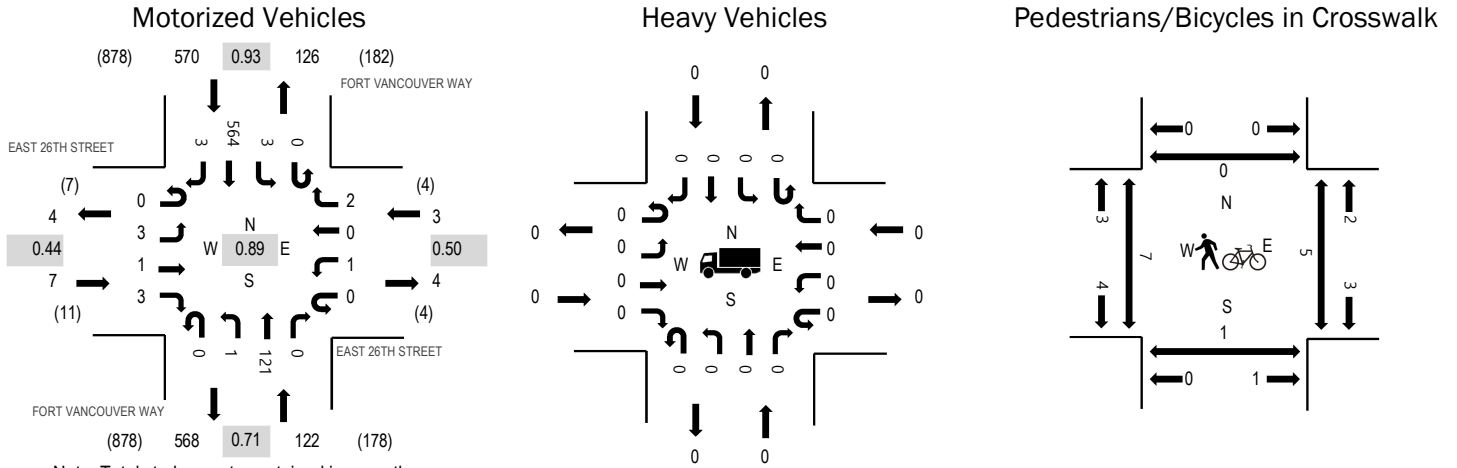

Note: Total study counts contained in parentheses.

	HV%	PHF
EB	0.0%	0.44
WB	0.0%	0.50
NB	0.0%	0.71
SB	0.0%	0.93
All	0.0%	0.89

Traffic Counts - Motorized Vehicles

Interval Start Time	EAST 26TH STREET Eastbound				EAST 26TH STREET Westbound				FORT VANCOUVER WAY Northbound				FORT VANCOUVER WAY Southbound				Total	Rolling Hour
	U-Turn	Left	Thru	Right	U-Turn	Left	Thru	Right	U-Turn	Left	Thru	Right	U-Turn	Left	Thru	Right		
6:30 AM	0	0	0	1	0	0	0	0	0	0	12	0	0	0	57	0	70	369
6:45 AM	0	0	0	1	0	0	0	0	0	0	15	0	0	0	79	0	95	445
7:00 AM	0	0	0	1	0	0	0	0	0	0	17	0	0	0	79	2	99	538
7:15 AM	0	0	0	1	0	1	0	0	0	0	12	0	0	0	90	1	105	610
7:30 AM	0	0	1	0	0	1	0	0	0	0	27	0	0	0	117	0	146	702
7:45 AM	0	3	0	1	0	0	0	2	0	0	28	0	0	2	152	0	188	
8:00 AM	0	0	0	0	0	0	0	0	0	0	24	0	0	1	143	3	171	
8:15 AM	0	0	0	2	0	0	0	0	0	1	42	0	0	0	152	0	197	
Count Total	0	3	1	7	0	2	0	2	0	1	177	0	0	3	869	6	1,071	
Peak Hour	0	3	1	3	0	1	0	2	0	1	121	0	0	3	564	3	702	

Traffic Counts - Heavy Vehicles, Bicycles on Road, and Pedestrians/Bicycles in Crosswalk

Interval Start Time	Heavy Vehicles					Interval Start Time	Bicycles on Roadway					Interval Start Time	Pedestrians/Bicycles on Crosswalk				
	EB	NB	WB	SB	Total		EB	NB	WB	SB	Total		EB	NB	WB	SB	Total
6:30 AM	0	0	0	0	0	6:30 AM	0	0	0	0	0	6:30 AM	0	0	0	0	0
6:45 AM	0	0	0	0	0	6:45 AM	0	0	0	0	0	6:45 AM	1	0	0	1	2
7:00 AM	0	1	0	0	1	7:00 AM	0	0	0	0	0	7:00 AM	1	1	0	0	2
7:15 AM	0	0	0	0	0	7:15 AM	0	0	0	0	0	7:15 AM	1	0	0	0	1
7:30 AM	0	0	0	0	0	7:30 AM	0	0	0	1	1	7:30 AM	2	1	0	0	3
7:45 AM	0	0	0	0	0	7:45 AM	0	0	0	0	0	7:45 AM	2	0	3	0	5
8:00 AM	0	0	0	0	0	8:00 AM	0	0	0	0	0	8:00 AM	0	0	0	0	0
8:15 AM	0	0	0	0	0	8:15 AM	0	0	0	0	0	8:15 AM	3	0	2	0	5
Count Total	0	1	0	0	1	Count Total	0	0	0	1	1	Count Total	10	2	5	1	18
Peak Hour	0	0	0	0	0	Peak Hour	0	0	0	1	1	Peak Hour	7	1	5	0	13

Peak Hour

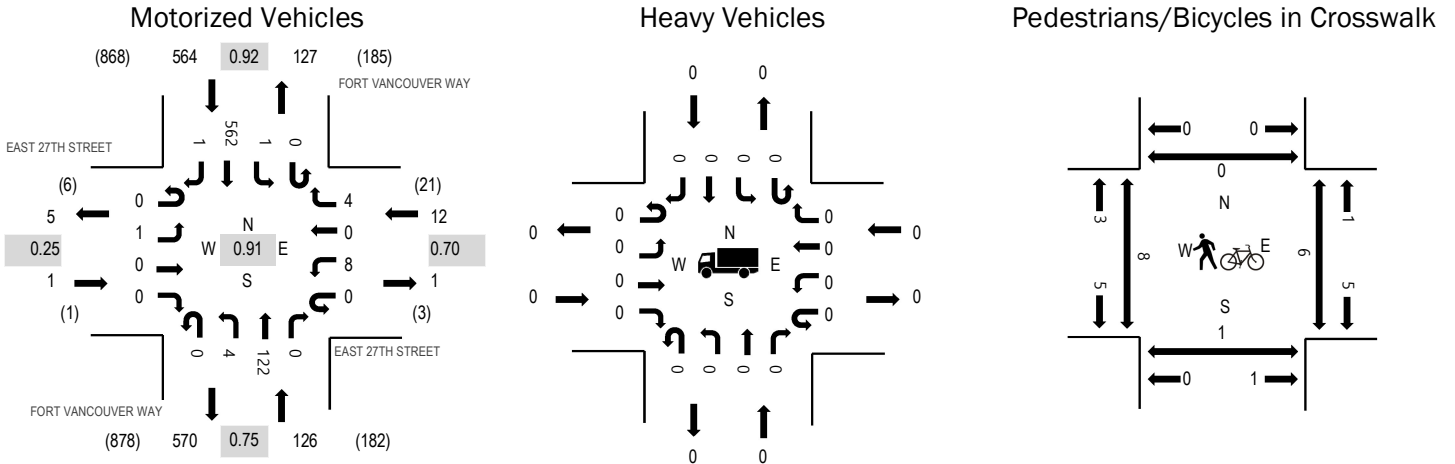

Note: Total study counts contained in parentheses.

	HV%	PHF
EB	0.0%	0.25
WB	0.0%	0.70
NB	0.0%	0.75
SB	0.0%	0.92
All	0.0%	0.91

Traffic Counts - Motorized Vehicles

Interval Start Time	EAST 27TH STREET Eastbound				EAST 27TH STREET Westbound				FORT VANCOUVER WAY Northbound				FORT VANCOUVER WAY Southbound				Total	Rolling Hour
	U-Turn	Left	Thru	Right	U-Turn	Left	Thru	Right	U-Turn	Left	Thru	Right	U-Turn	Left	Thru	Right		
6:30 AM	0	0	0	0	0	1	0	0	0	0	11	1	0	0	56	0	69	369
6:45 AM	0	0	0	0	0	0	0	0	0	0	14	0	0	1	81	0	96	443
7:00 AM	0	0	0	0	0	1	0	2	0	0	18	0	0	0	78	0	99	539
7:15 AM	0	0	0	0	0	3	1	1	0	0	12	0	0	0	88	0	105	614
7:30 AM	0	0	0	0	0	1	0	1	0	0	25	0	0	0	116	0	143	703
7:45 AM	0	1	0	0	0	1	0	3	0	2	32	0	0	0	153	0	192	
8:00 AM	0	0	0	0	0	2	0	0	0	2	23	0	0	0	146	1	174	
8:15 AM	0	0	0	0	0	4	0	0	0	0	42	0	0	1	147	0	194	
Count Total	0	1	0	0	0	13	1	7	0	4	177	1	0	2	865	1	1,072	
Peak Hour	0	1	0	0	0	8	0	4	0	4	122	0	0	1	562	1	703	

Traffic Counts - Heavy Vehicles, Bicycles on Road, and Pedestrians/Bicycles in Crosswalk

Interval Start Time	Heavy Vehicles					Interval Start Time	Bicycles on Roadway					Interval Start Time	Pedestrians/Bicycles on Crosswalk				
	EB	NB	WB	SB	Total		EB	NB	WB	SB	Total		EB	NB	WB	SB	Total
6:30 AM	0	0	0	0	0	6:30 AM	0	0	0	0	0	6:30 AM	0	0	0	0	0
6:45 AM	0	0	0	0	0	6:45 AM	0	0	0	0	0	6:45 AM	2	0	1	0	3
7:00 AM	0	1	0	0	1	7:00 AM	0	0	0	0	0	7:00 AM	1	0	0	0	1
7:15 AM	0	0	0	0	0	7:15 AM	0	0	0	0	0	7:15 AM	1	0	0	0	1
7:30 AM	0	0	0	0	0	7:30 AM	0	0	0	1	1	7:30 AM	3	1	0	0	4
7:45 AM	0	0	0	0	0	7:45 AM	0	0	0	0	0	7:45 AM	2	0	3	0	5
8:00 AM	0	0	0	0	0	8:00 AM	0	0	0	0	0	8:00 AM	0	0	1	0	1
8:15 AM	0	0	0	0	0	8:15 AM	0	0	0	0	0	8:15 AM	3	0	2	0	5
Count Total	0	1	0	0	1	Count Total	0	0	0	1	1	Count Total	12	1	7	0	20
Peak Hour	0	0	0	0	0	Peak Hour	0	0	0	1	1	Peak Hour	8	1	6	0	15

Peak Hour

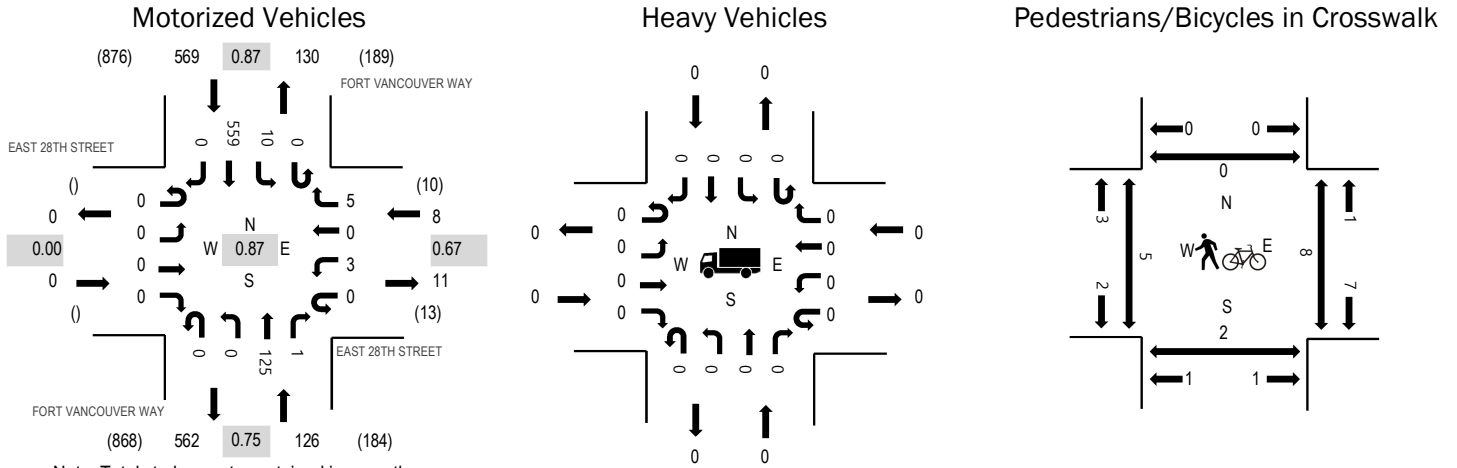

Note: Total study counts contained in parentheses.

	HV%	PHF
EB	0.0%	0.00
WB	0.0%	0.67
NB	0.0%	0.75
SB	0.0%	0.87
All	0.0%	0.87

Traffic Counts - Motorized Vehicles

Interval Start Time	EAST 28TH STREET Eastbound				EAST 28TH STREET Westbound				FORT VANCOUVER WAY Northbound				FORT VANCOUVER WAY Southbound				Total	Rolling Hour
	U-Turn	Left	Thru	Right	U-Turn	Left	Thru	Right	U-Turn	Left	Thru	Right	U-Turn	Left	Thru	Right		
6:30 AM	0	0	0	0	0	1	0	0	0	0	11	0	0	0	56	0	68	367
6:45 AM	0	0	0	0	0	0	0	0	0	0	12	0	0	0	85	0	97	444
7:00 AM	0	0	0	0	0	0	0	0	0	0	22	0	0	2	76	0	100	548
7:15 AM	0	0	0	0	0	0	0	1	0	0	13	0	0	0	88	0	102	614
7:30 AM	0	0	0	0	0	2	0	1	0	0	25	1	0	1	115	0	145	703
7:45 AM	0	0	0	0	0	0	0	2	0	0	35	0	0	6	158	0	201	
8:00 AM	0	0	0	0	0	1	0	1	0	0	23	0	0	2	139	0	166	
8:15 AM	0	0	0	0	0	0	0	1	0	0	42	0	0	1	147	0	191	
Count Total	0	0	0	0	0	4	0	6	0	0	183	1	0	12	864	0	1,070	
Peak Hour	0	0	0	0	0	3	0	5	0	0	125	1	0	10	559	0	703	

Traffic Counts - Heavy Vehicles, Bicycles on Road, and Pedestrians/Bicycles in Crosswalk

Interval Start Time	Heavy Vehicles					Interval Start Time	Bicycles on Roadway					Interval Start Time	Pedestrians/Bicycles on Crosswalk				
	EB	NB	WB	SB	Total		EB	NB	WB	SB	Total		EB	NB	WB	SB	Total
6:30 AM	0	0	0	0	0	6:30 AM	0	0	0	0	0	6:30 AM	0	0	0	0	0
6:45 AM	0	0	0	0	0	6:45 AM	0	0	0	0	0	6:45 AM	0	1	2	0	3
7:00 AM	0	1	0	0	1	7:00 AM	0	0	0	0	0	7:00 AM	0	1	1	0	2
7:15 AM	0	0	0	0	0	7:15 AM	0	0	0	0	0	7:15 AM	0	0	0	0	0
7:30 AM	0	0	0	0	0	7:30 AM	0	0	0	0	0	7:30 AM	2	0	0	0	2
7:45 AM	0	0	0	0	0	7:45 AM	0	0	0	0	0	7:45 AM	0	1	4	0	5
8:00 AM	0	0	0	0	0	8:00 AM	0	0	0	0	0	8:00 AM	0	1	0	0	1
8:15 AM	0	0	0	0	0	8:15 AM	0	0	0	0	0	8:15 AM	3	0	4	0	7
Count Total	0	1	0	0	1	Count Total	0	0	0	0	0	Count Total	5	4	11	0	20
Peak Hour	0	0	0	0	0	Peak Hour	0	0	0	0	0	Peak Hour	5	2	8	0	15

Location: 1 FORT VANCOUVER WAY & EAST 25TH STREET AM

Date: Saturday, March 2, 2024

Peak Hour: 12:15 PM - 01:15 PM

Peak 15-Minutes: 12:45 PM - 01:00 PM

Peak Hour

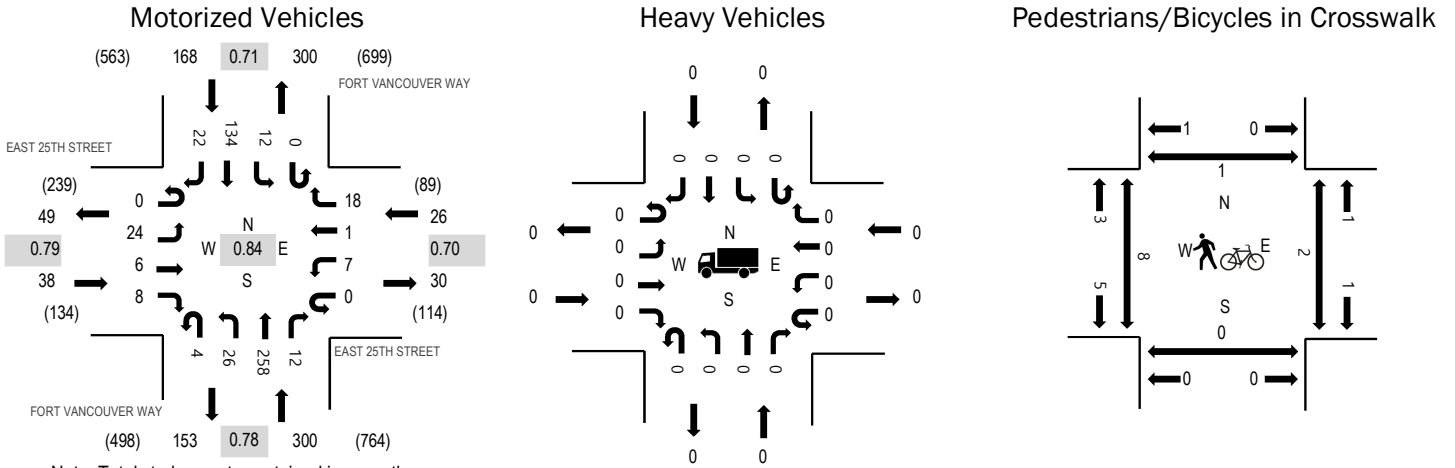

Note: Total study counts contained in parentheses.

	HV%	PHF
EB	0.0%	0.79
WB	0.0%	0.70
NB	0.0%	0.78
SB	0.0%	0.71
All	0.0%	0.84

Traffic Counts - Motorized Vehicles

Interval Start Time	EAST 25TH STREET Eastbound				EAST 25TH STREET Westbound				FORT VANCOUVER WAY Northbound				FORT VANCOUVER WAY Southbound				Total	Rolling Hour
	U-Turn	Left	Thru	Right	U-Turn	Left	Thru	Right	U-Turn	Left	Thru	Right	U-Turn	Left	Thru	Right		
10:00 AM	0	11	0	1	0	2	0	0	0	12	18	4	0	5	22	9	84	320
10:15 AM	0	4	1	2	0	4	1	3	2	10	18	1	0	3	20	5	74	293
10:30 AM	0	4	1	4	0	2	0	4	0	8	26	0	0	4	17	11	81	314
10:45 AM	0	2	2	3	0	2	0	2	1	7	22	4	0	3	31	2	81	311
11:00 AM	0	5	0	0	0	0	0	1	0	5	22	2	0	4	12	6	57	319
11:15 AM	0	6	2	2	0	3	0	4	0	6	31	2	0	5	27	7	95	357
11:30 AM	0	2	0	3	0	0	1	1	0	9	24	3	0	4	21	10	78	352
11:45 AM	0	6	1	4	0	3	0	2	1	12	27	6	0	3	19	5	89	403
12:00 PM	0	6	0	2	0	4	0	2	2	13	29	6	0	1	25	5	95	473
12:15 PM	0	6	0	2	0	2	0	6	0	7	44	0	0	1	21	1	90	532
12:30 PM	0	2	2	1	0	2	0	2	2	9	59	6	0	3	36	5	129	529
12:45 PM	0	7	2	3	0	2	1	7	1	3	68	5	0	5	48	7	159	496
1:00 PM	0	9	2	2	0	1	0	3	1	7	87	1	0	3	29	9	154	438
1:15 PM	0	6	1	2	0	1	0	7	0	12	33	0	0	3	20	2	87	
1:30 PM	0	4	0	3	0	3	0	3	2	9	33	3	0	2	24	10	96	
1:45 PM	0	4	0	2	0	5	1	2	2	9	25	3	0	5	40	3	101	
Count Total	0	84	14	36	0	36	4	49	14	138	566	46	0	54	412	97	1,550	
Peak Hour	0	24	6	8	0	7	1	18	4	26	258	12	0	12	134	22	532	

Traffic Counts - Heavy Vehicles, Bicycles on Road, and Pedestrians/Bicycles in Crosswalk

Interval Start Time	Heavy Vehicles					Interval Start Time	Bicycles on Roadway					Interval Start Time	Pedestrians/Bicycles on Crosswalk				
	EB	NB	WB	SB	Total		EB	NB	WB	SB	Total		EB	NB	WB	SB	Total
10:00 AM	0	0	0	0	0	10:00 AM	0	0	0	0	0	10:00 AM	1	0	1	0	2
10:15 AM	0	0	0	0	0	10:15 AM	0	0	0	0	0	10:15 AM	0	0	3	2	5
10:30 AM	0	0	0	0	0	10:30 AM	0	0	0	0	0	10:30 AM	1	0	0	0	1
10:45 AM	0	0	0	0	0	10:45 AM	0	0	0	0	0	10:45 AM	1	0	0	0	1
11:00 AM	0	0	0	0	0	11:00 AM	0	1	0	0	1	11:00 AM	1	0	1	0	2

11:15 AM	0	0	0	0	0	11:15 AM	0	0	0	0	0	11:15 AM	2	0	0	0	2
11:30 AM	0	0	0	0	0	11:30 AM	0	0	0	0	0	11:30 AM	1	0	3	0	4
11:45 AM	0	0	0	0	0	11:45 AM	0	0	0	1	1	11:45 AM	2	0	0	0	2
12:00 PM	0	0	0	0	0	12:00 PM	0	0	0	0	0	12:00 PM	0	0	3	1	4
12:15 PM	0	0	0	0	0	12:15 PM	0	0	0	0	0	12:15 PM	0	0	1	0	1
12:30 PM	0	0	0	0	0	12:30 PM	0	0	0	0	0	12:30 PM	0	0	0	0	0
12:45 PM	0	0	0	0	0	12:45 PM	0	2	0	0	2	12:45 PM	3	0	0	1	4
1:00 PM	0	0	0	0	0	1:00 PM	0	0	0	0	0	1:00 PM	5	0	1	0	6
1:15 PM	0	0	0	0	0	1:15 PM	0	0	0	0	0	1:15 PM	3	0	1	1	5
1:30 PM	0	0	0	0	0	1:30 PM	0	0	0	0	0	1:30 PM	6	0	1	0	7
1:45 PM	0	0	1	0	1	1:45 PM	0	0	0	0	0	1:45 PM	0	0	1	0	1
Count Total	0	0	1	0	1	Count Total	0	3	0	1	4	Count Total	26	0	16	5	47
Peak Hour	0	0	0	0	0	Peak Hour	0	2	0	0	2	Peak Hour	8	0	2	1	11

Peak Hour

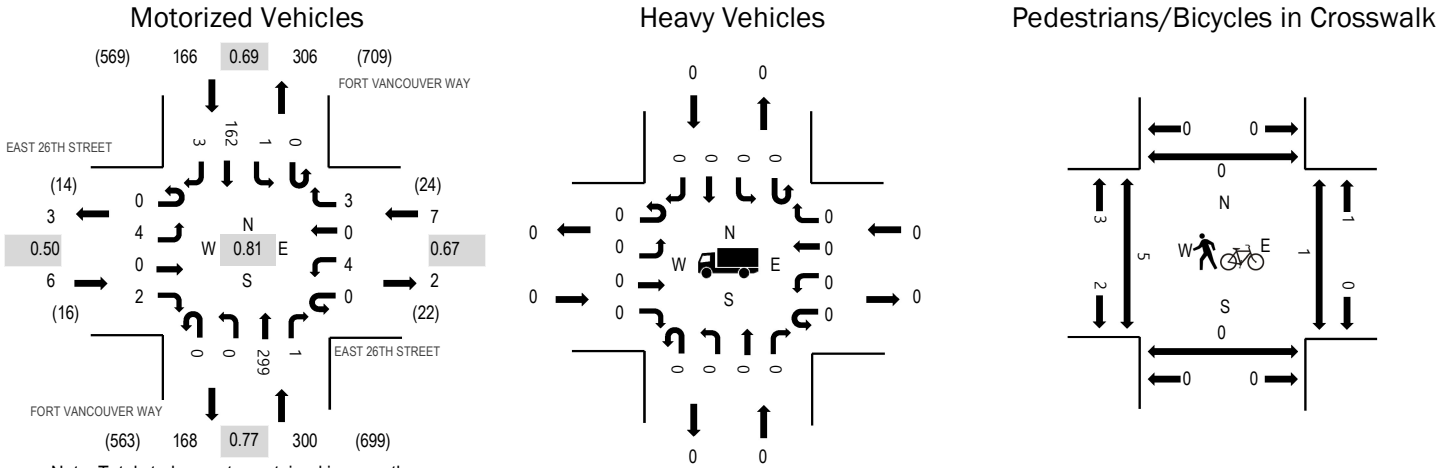

Note: Total study counts contained in parentheses.

	HV%	PHF
EB	0.0%	0.50
WB	0.0%	0.67
NB	0.0%	0.77
SB	0.0%	0.69
All	0.0%	0.81

Traffic Counts - Motorized Vehicles

Interval Start Time	EAST 26TH STREET Eastbound				EAST 26TH STREET Westbound				FORT VANCOUVER WAY Northbound				FORT VANCOUVER WAY Southbound				Total	Rolling Hour
	U-Turn	Left	Thru	Right	U-Turn	Left	Thru	Right	U-Turn	Left	Thru	Right	U-Turn	Left	Thru	Right		
10:00 AM	0	0	0	1	0	1	0	2	0	0	27	1	0	3	34	1	70	260
10:15 AM	0	0	0	0	0	1	0	1	0	1	24	0	0	1	28	1	57	244
10:30 AM	0	0	0	1	0	0	1	0	0	0	33	1	0	0	31	0	67	271
10:45 AM	0	0	0	0	0	0	0	2	0	0	28	0	0	0	35	1	66	267
11:00 AM	0	2	0	0	0	0	0	1	0	0	28	0	0	0	23	0	54	265
11:15 AM	0	0	0	2	0	0	0	2	0	1	39	1	0	3	36	0	84	282
11:30 AM	0	0	0	0	0	0	0	1	0	0	26	0	0	0	36	0	63	279
11:45 AM	0	0	0	0	0	1	0	1	0	0	34	2	0	1	25	0	64	327
12:00 PM	0	1	0	0	0	0	0	0	0	1	33	2	0	2	31	1	71	411
12:15 PM	0	0	0	0	0	2	0	1	0	0	57	0	0	0	21	0	81	479
12:30 PM	0	2	0	0	0	1	0	1	0	0	63	0	0	0	43	1	111	472
12:45 PM	0	2	0	1	0	0	0	1	0	0	82	0	0	1	60	1	148	439
1:00 PM	0	0	0	1	0	1	0	0	0	0	97	1	0	0	38	1	139	372
1:15 PM	0	0	0	0	0	0	0	0	0	0	46	1	0	1	25	1	74	
1:30 PM	0	0	0	1	0	1	0	0	0	1	38	0	0	1	35	1	78	
1:45 PM	0	1	0	1	0	0	0	2	0	0	31	0	0	0	46	0	81	
Count Total	0	8	0	8	0	8	1	15	0	4	686	9	0	13	547	9	1,308	
Peak Hour	0	4	0	2	0	4	0	3	0	0	299	1	0	1	162	3	479	

Traffic Counts - Heavy Vehicles, Bicycles on Road, and Pedestrians/Bicycles in Crosswalk

Interval Start Time	Heavy Vehicles					Interval Start Time	Bicycles on Roadway					Interval Start Time	Pedestrians/Bicycles on Crosswalk				
	EB	NB	WB	SB	Total		EB	NB	WB	SB	Total		EB	NB	WB	SB	Total
10:00 AM	0	0	0	0	0	10:00 AM	0	0	0	0	0	10:00 AM	1	0	0	0	1
10:15 AM	0	0	0	0	0	10:15 AM	0	0	0	0	0	10:15 AM	2	0	1	0	3
10:30 AM	0	0	0	0	0	10:30 AM	0	0	0	0	0	10:30 AM	1	0	2	0	3
10:45 AM	0	0	0	0	0	10:45 AM	0	0	0	0	0	10:45 AM	1	0	0	0	1
11:00 AM	0	0	0	0	0	11:00 AM	0	1	1	0	2	11:00 AM	1	0	0	0	1

11:15 AM	0	0	0	0	0	11:15 AM	0	0	0	0	0	11:15 AM	1	0	0	0	1
11:30 AM	0	0	0	0	0	11:30 AM	0	0	0	0	0	11:30 AM	0	0	3	1	4
11:45 AM	0	0	0	0	0	11:45 AM	0	0	0	1	1	11:45 AM	1	0	0	0	1
12:00 PM	0	0	0	0	0	12:00 PM	0	0	0	0	0	12:00 PM	0	0	6	0	6
12:15 PM	0	0	0	0	0	12:15 PM	0	0	0	0	0	12:15 PM	0	0	0	0	0
12:30 PM	0	0	0	0	0	12:30 PM	0	0	0	0	0	12:30 PM	0	0	0	0	0
12:45 PM	0	0	0	0	0	12:45 PM	0	1	0	0	1	12:45 PM	0	0	0	0	0
1:00 PM	0	0	0	0	0	1:00 PM	0	0	0	0	0	1:00 PM	5	0	1	0	6
1:15 PM	0	0	0	0	0	1:15 PM	0	0	0	0	0	1:15 PM	2	0	1	0	3
1:30 PM	0	0	0	0	0	1:30 PM	0	0	0	0	0	1:30 PM	5	0	1	0	6
1:45 PM	0	0	0	0	0	1:45 PM	0	0	0	0	0	1:45 PM	5	0	1	0	6
Count Total	0	0	0	0	0	Count Total	0	2	1	1	4	Count Total	25	0	16	1	42
Peak Hour	0	0	0	0	0	Peak Hour	0	1	0	0	1	Peak Hour	5	0	1	0	6

Peak Hour

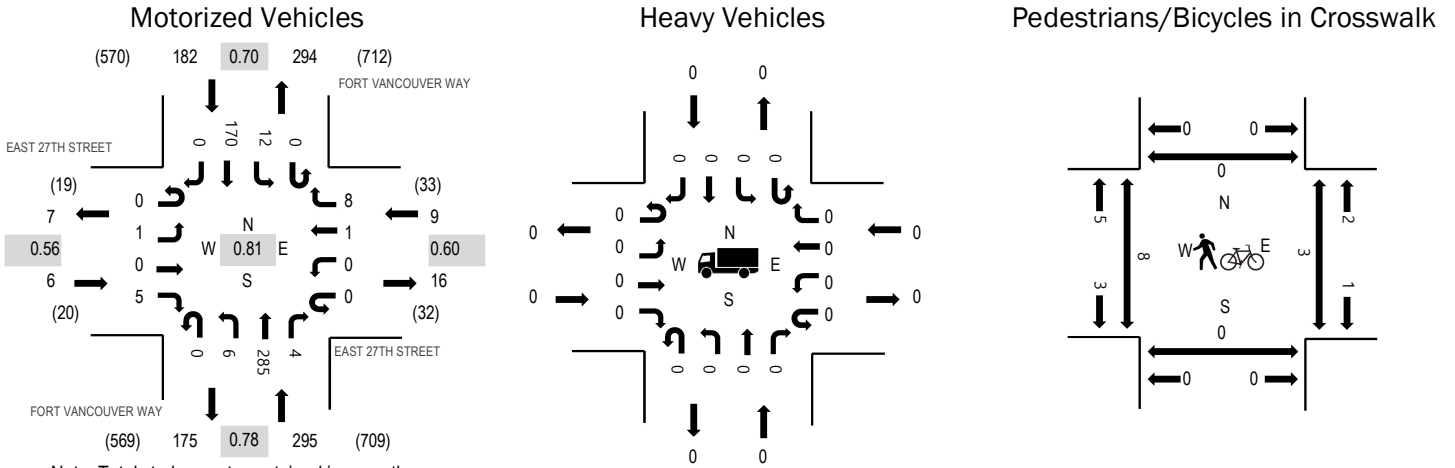

Note: Total study counts contained in parentheses.

	HV%	PHF
EB	0.0%	0.56
WB	0.0%	0.60
NB	0.0%	0.78
SB	0.0%	0.70
All	0.0%	0.81

Traffic Counts - Motorized Vehicles

Interval Start Time	EAST 27TH STREET Eastbound				EAST 27TH STREET Westbound				FORT VANCOUVER WAY Northbound				FORT VANCOUVER WAY Southbound				Total	Rolling Hour
	U-Turn	Left	Thru	Right	U-Turn	Left	Thru	Right	U-Turn	Left	Thru	Right	U-Turn	Left	Thru	Right		
10:00 AM	0	0	0	1	0	0	0	0	0	0	29	0	0	0	37	0	67	260
10:15 AM	0	0	0	1	0	0	0	2	0	0	24	1	0	0	30	1	59	249
10:30 AM	0	0	0	1	0	0	0	0	0	0	33	0	0	1	31	0	66	269
10:45 AM	0	0	0	2	0	0	0	4	0	0	30	0	0	0	32	0	68	273
11:00 AM	0	1	0	0	0	0	0	0	0	0	29	2	0	1	23	0	56	269
11:15 AM	0	0	0	0	0	3	0	0	0	1	39	1	0	0	35	0	79	285
11:30 AM	0	0	1	1	0	1	0	2	0	1	26	0	0	4	34	0	70	286
11:45 AM	0	0	0	0	0	0	0	1	0	1	34	0	0	1	26	1	64	334
12:00 PM	0	0	0	0	0	2	0	2	0	2	32	0	0	0	34	0	72	422
12:15 PM	0	0	0	0	0	0	0	1	0	3	54	0	0	1	20	1	80	488
12:30 PM	0	0	0	1	0	0	1	1	0	0	66	1	0	5	43	0	118	492
12:45 PM	0	1	0	2	0	0	0	1	0	1	81	1	0	3	62	0	152	453
1:00 PM	0	0	0	2	0	0	0	1	0	3	94	1	0	1	36	0	138	381
1:15 PM	0	0	0	0	0	0	0	5	0	2	44	1	0	3	29	0	84	
1:30 PM	0	1	1	2	0	1	0	3	0	1	37	0	0	2	31	0	79	
1:45 PM	0	0	0	2	0	2	0	0	0	0	34	0	0	0	42	0	80	
Count Total	0	3	2	15	0	9	1	23	0	15	686	8	0	22	545	3	1,332	
Peak Hour	0	1	0	5	0	0	1	8	0	6	285	4	0	12	170	0	492	

Traffic Counts - Heavy Vehicles, Bicycles on Road, and Pedestrians/Bicycles in Crosswalk

Interval Start Time	Heavy Vehicles					Interval Start Time	Bicycles on Roadway					Interval Start Time	Pedestrians/Bicycles on Crosswalk				
	EB	NB	WB	SB	Total		EB	NB	WB	SB	Total		EB	NB	WB	SB	Total
10:00 AM	0	0	0	0	0	10:00 AM	0	0	0	0	0	10:00 AM	1	0	0	0	1
10:15 AM	0	0	0	0	0	10:15 AM	0	0	0	0	0	10:15 AM	2	0	0	0	2
10:30 AM	0	0	0	0	0	10:30 AM	0	0	0	0	0	10:30 AM	1	0	3	0	4
10:45 AM	0	0	0	0	0	10:45 AM	0	0	0	0	0	10:45 AM	1	0	0	0	1
11:00 AM	0	0	0	0	0	11:00 AM	0	2	0	0	2	11:00 AM	1	0	0	0	1

11:15 AM	0	0	0	0	0	11:15 AM	0	0	0	0	0	11:15 AM	0	1	1	0	2
11:30 AM	0	0	0	0	0	11:30 AM	0	0	0	0	0	11:30 AM	1	2	1	1	5
11:45 AM	0	0	0	0	0	11:45 AM	0	0	0	1	1	11:45 AM	0	0	0	0	0
12:00 PM	0	0	0	0	0	12:00 PM	0	0	0	0	0	12:00 PM	5	3	3	0	11
12:15 PM	0	0	0	0	0	12:15 PM	0	0	0	0	0	12:15 PM	0	0	0	1	1
12:30 PM	0	0	0	0	0	12:30 PM	0	0	0	0	0	12:30 PM	1	0	0	0	1
12:45 PM	0	0	0	0	0	12:45 PM	0	1	0	0	1	12:45 PM	0	0	1	0	1
1:00 PM	0	0	0	0	0	1:00 PM	0	0	0	0	0	1:00 PM	4	0	1	0	5
1:15 PM	0	0	0	0	0	1:15 PM	0	0	0	0	0	1:15 PM	3	0	1	0	4
1:30 PM	0	0	0	0	0	1:30 PM	0	0	0	0	0	1:30 PM	5	0	1	0	6
1:45 PM	0	0	0	0	0	1:45 PM	0	0	0	0	0	1:45 PM	1	0	1	0	2
Count Total	0	0	0	0	0	Count Total	0	3	0	1	4	Count Total	26	6	13	2	47
Peak Hour	0	0	0	0	0	Peak Hour	0	1	0	0	1	Peak Hour	8	0	3	0	11

Peak Hour

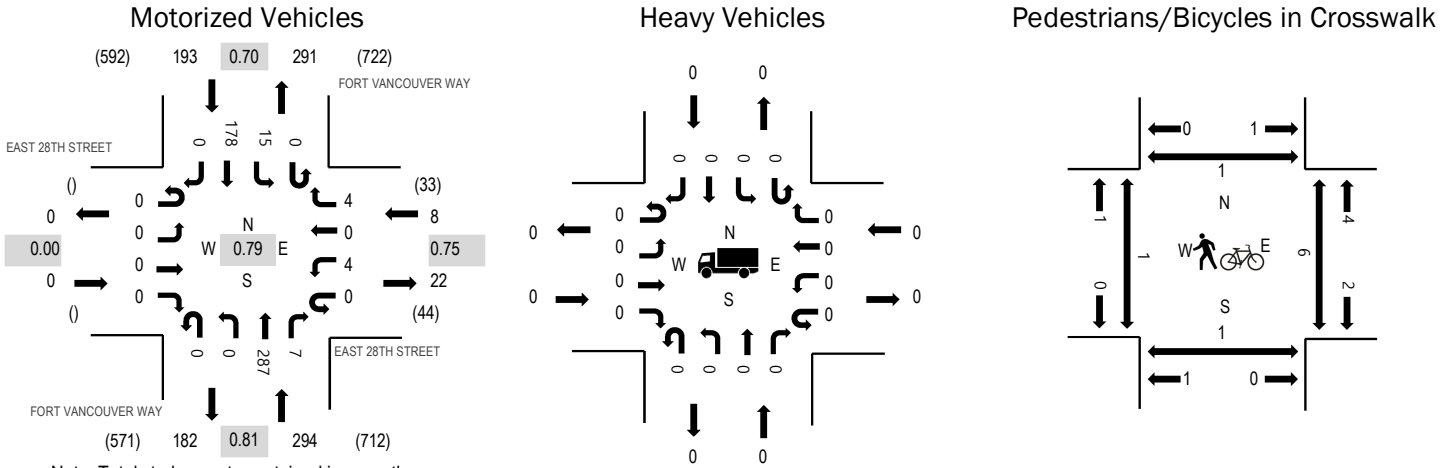

Note: Total study counts contained in parentheses.

	HV%	PHF
EB	0.0%	0.00
WB	0.0%	0.75
NB	0.0%	0.81
SB	0.0%	0.70
All	0.0%	0.79

Traffic Counts - Motorized Vehicles

Interval Start Time	EAST 28TH STREET Eastbound				EAST 28TH STREET Westbound				FORT VANCOUVER WAY Northbound				FORT VANCOUVER WAY Southbound				Total	Rolling Hour
	U-Turn	Left	Thru	Right	U-Turn	Left	Thru	Right	U-Turn	Left	Thru	Right	U-Turn	Left	Thru	Right		
10:00 AM	0	0	0	0	0	0	0	2	0	0	28	0	0	2	39	0	71	263
10:15 AM	0	0	0	0	0	0	0	0	0	0	27	0	0	0	29	0	56	250
10:30 AM	0	0	0	0	0	0	0	1	0	0	33	0	0	0	32	0	66	270
10:45 AM	0	0	0	0	0	0	0	4	0	0	31	2	0	1	32	0	70	274
11:00 AM	0	0	0	0	0	1	0	2	0	0	31	0	0	0	24	0	58	272
11:15 AM	0	0	0	0	0	0	0	2	0	0	38	1	0	0	35	0	76	282
11:30 AM	0	0	0	0	0	0	0	3	0	0	24	2	0	1	40	0	70	286
11:45 AM	0	0	0	0	0	1	0	1	0	0	36	1	0	5	24	0	68	336
12:00 PM	0	0	0	0	0	0	0	1	0	0	32	1	0	0	34	0	68	425
12:15 PM	0	0	0	0	0	1	0	1	0	0	56	0	0	1	21	0	80	488
12:30 PM	0	0	0	0	0	1	0	1	0	0	65	0	0	5	48	0	120	495
12:45 PM	0	0	0	0	0	2	0	1	0	0	80	5	0	7	62	0	157	454
1:00 PM	0	0	0	0	0	0	0	0	0	0	90	2	0	2	37	0	131	377
1:15 PM	0	0	0	0	0	1	0	2	0	0	52	0	0	1	31	0	87	
1:30 PM	0	0	0	0	0	1	0	1	0	0	41	0	0	3	33	0	79	
1:45 PM	0	0	0	0	0	0	0	3	0	0	33	1	0	1	42	0	80	
Count Total	0	0	0	0	0	8	0	25	0	0	697	15	0	29	563	0	1,337	
Peak Hour	0	0	0	0	0	4	0	4	0	0	287	7	0	15	178	0	495	

Traffic Counts - Heavy Vehicles, Bicycles on Road, and Pedestrians/Bicycles in Crosswalk

Interval Start Time	Heavy Vehicles					Interval Start Time	Bicycles on Roadway					Interval Start Time	Pedestrians/Bicycles on Crosswalk				
	EB	NB	WB	SB	Total		EB	NB	WB	SB	Total		EB	NB	WB	SB	Total
10:00 AM	0	0	0	0	0	10:00 AM	0	0	0	0	0	10:00 AM	1	0	0	0	1
10:15 AM	0	0	0	0	0	10:15 AM	0	0	0	0	0	10:15 AM	2	0	0	0	2
10:30 AM	0	0	0	0	0	10:30 AM	0	0	0	0	0	10:30 AM	3	2	1	1	7
10:45 AM	0	0	0	0	0	10:45 AM	0	0	0	0	0	10:45 AM	0	0	0	0	0
11:00 AM	0	0	0	0	0	11:00 AM	0	2	0	0	2	11:00 AM	1	0	1	1	3

11:15 AM	0	0	0	0	0	11:15 AM	0	0	0	0	0	11:15 AM	0	0	1	0	1
11:30 AM	0	0	0	0	0	11:30 AM	0	0	0	0	0	11:30 AM	0	0	0	0	0
11:45 AM	0	0	0	0	0	11:45 AM	0	0	0	1	1	11:45 AM	0	0	1	0	1
12:00 PM	0	0	0	0	0	12:00 PM	0	0	0	0	0	12:00 PM	1	0	3	0	4
12:15 PM	0	0	0	0	0	12:15 PM	0	0	0	0	0	12:15 PM	0	0	0	0	0
12:30 PM	0	0	0	0	0	12:30 PM	0	0	0	0	0	12:30 PM	0	0	0	0	0
12:45 PM	0	0	0	0	0	12:45 PM	0	1	0	0	1	12:45 PM	0	0	1	0	1
1:00 PM	0	0	0	0	0	1:00 PM	0	0	0	0	0	1:00 PM	0	1	4	1	6
1:15 PM	0	0	0	0	0	1:15 PM	0	0	0	0	0	1:15 PM	1	0	1	0	2
1:30 PM	0	0	0	0	0	1:30 PM	0	0	0	0	0	1:30 PM	0	3	4	0	7
1:45 PM	0	0	0	0	0	1:45 PM	0	0	0	0	0	1:45 PM	0	1	2	0	3
Count Total	0	0	0	0	0	Count Total	0	3	0	1	4	Count Total	9	7	19	3	38
Peak Hour	0	0	0	0	0	Peak Hour	0	1	0	0	1	Peak Hour	1	1	6	1	9

Peak Hour

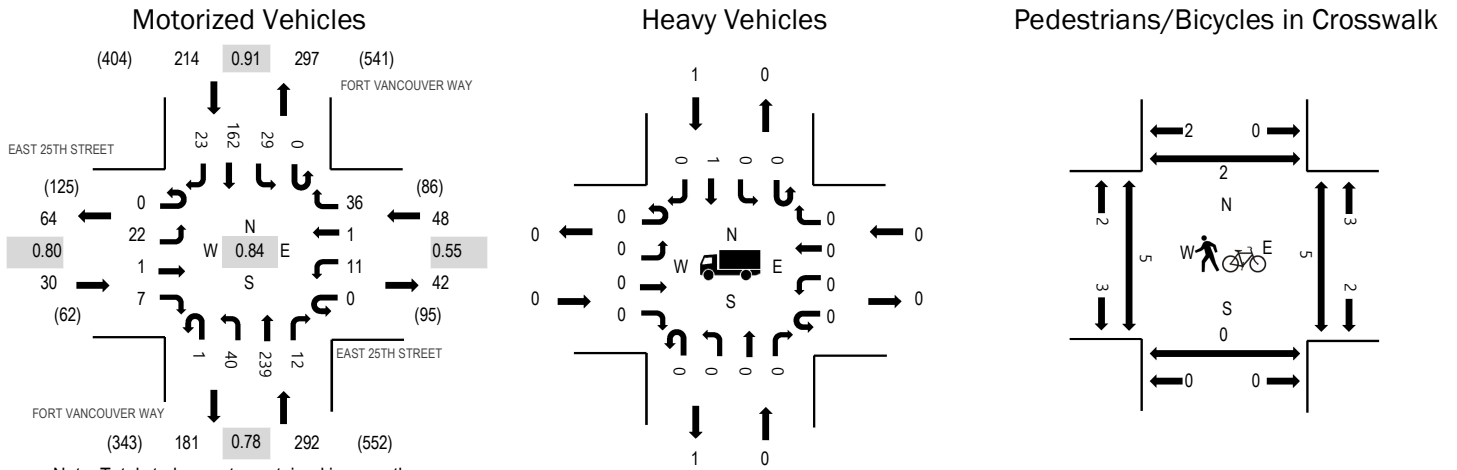

	HV%	PHF
EB	0.0%	0.80
WB	0.0%	0.55
NB	0.0%	0.78
SB	0.5%	0.91
All	0.2%	0.84

Traffic Counts - Motorized Vehicles

Interval Start Time	EAST 25TH STREET Eastbound				EAST 25TH STREET Westbound				FORT VANCOUVER WAY Northbound				FORT VANCOUVER WAY Southbound				Total	Rolling Hour
	U-Turn	Left	Thru	Right	U-Turn	Left	Thru	Right	U-Turn	Left	Thru	Right	U-Turn	Left	Thru	Right		
4:00 PM	0	5	4	1	0	3	1	6	1	12	65	6	0	4	28	6	142	520
4:15 PM	0	3	2	2	0	4	0	5	0	6	44	5	0	7	30	7	115	552
4:30 PM	0	3	3	1	0	3	1	5	1	8	50	5	0	8	36	4	128	582
4:45 PM	0	4	0	2	0	5	0	2	0	6	59	1	0	8	40	8	135	584
5:00 PM	0	8	1	1	0	3	0	20	0	15	75	5	0	5	38	3	174	584
5:15 PM	0	4	0	2	0	1	1	8	1	9	57	3	0	9	44	6	145	
5:30 PM	0	6	0	2	0	2	0	6	0	10	48	3	0	7	40	6	130	
5:45 PM	0	4	2	2	0	1	4	5	0	6	49	2	0	5	49	6	135	
Count Total	0	37	12	13	0	22	7	57	3	72	447	30	0	53	305	46	1,104	
Peak Hour	0	22	1	7	0	11	1	36	1	40	239	12	0	29	162	23	584	

Traffic Counts - Heavy Vehicles, Bicycles on Road, and Pedestrians/Bicycles in Crosswalk

Interval Start Time	Heavy Vehicles					Interval Start Time	Bicycles on Roadway					Interval Start Time	Pedestrians/Bicycles on Crosswalk				
	EB	NB	WB	SB	Total		EB	NB	WB	SB	Total		EB	NB	WB	SB	Total
4:00 PM	0	0	0	0	0	4:00 PM	0	0	0	0	0	4:00 PM	4	0	2	0	6
4:15 PM	0	0	0	0	0	4:15 PM	0	1	0	0	1	4:15 PM	1	0	2	0	3
4:30 PM	0	1	0	0	1	4:30 PM	0	1	0	0	1	4:30 PM	2	0	0	0	2
4:45 PM	0	0	0	0	0	4:45 PM	0	0	0	0	0	4:45 PM	0	0	0	0	0
5:00 PM	0	0	0	1	1	5:00 PM	0	0	0	0	0	5:00 PM	0	0	1	2	3
5:15 PM	0	0	0	0	0	5:15 PM	0	0	0	0	0	5:15 PM	2	0	3	0	5
5:30 PM	0	0	0	0	0	5:30 PM	0	0	0	0	0	5:30 PM	3	0	1	0	4
5:45 PM	0	0	0	0	0	5:45 PM	0	0	0	0	0	5:45 PM	1	0	4	2	7
Count Total	0	1	0	1	2	Count Total	0	2	0	0	2	Count Total	13	0	13	4	30
Peak Hour	0	0	0	1	1	Peak Hour	0	0	0	0	0	Peak Hour	5	0	5	2	12

Peak Hour

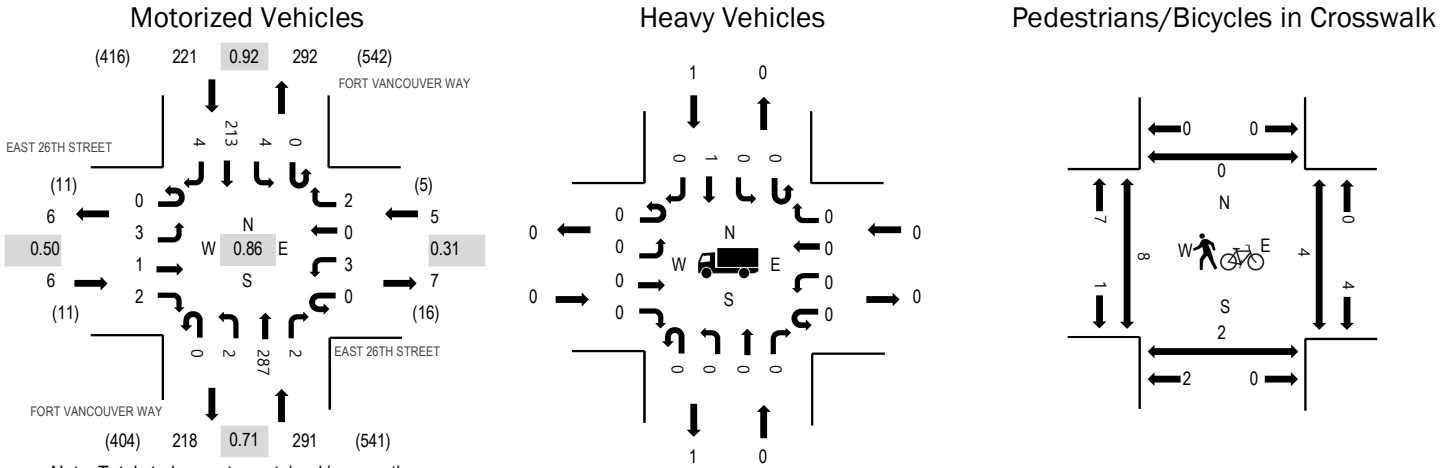

Note: Total study counts contained in parentheses.

	HV%	PHF
EB	0.0%	0.50
WB	0.0%	0.31
NB	0.0%	0.71
SB	0.5%	0.92
All	0.2%	0.86

Traffic Counts - Motorized Vehicles

Interval Start Time	EAST 26TH STREET Eastbound				EAST 26TH STREET Westbound				FORT VANCOUVER WAY Northbound				FORT VANCOUVER WAY Southbound				Total	Rolling Hour
	U-Turn	Left	Thru	Right	U-Turn	Left	Thru	Right	U-Turn	Left	Thru	Right	U-Turn	Left	Thru	Right		
4:00 PM	0	2	0	0	0	0	0	0	0	1	75	0	0	3	40	2	123	450
4:15 PM	0	1	0	1	0	0	0	0	0	1	51	0	0	1	41	1	97	479
4:30 PM	0	0	0	0	0	0	0	0	0	0	58	0	0	3	49	0	110	510
4:45 PM	0	0	1	0	0	0	0	0	0	0	63	1	0	0	55	0	120	519
5:00 PM	0	0	0	0	0	1	0	0	0	1	103	0	0	1	46	0	152	523
5:15 PM	0	1	0	2	0	0	0	0	0	0	69	0	0	0	56	0	128	
5:30 PM	0	0	1	0	0	0	0	0	0	0	60	0	0	2	54	2	119	
5:45 PM	0	2	0	0	0	2	0	2	0	1	55	2	0	1	57	2	124	
Count Total	0	6	2	3	0	3	0	2	0	4	534	3	0	11	398	7	973	
Peak Hour	0	3	1	2	0	3	0	2	0	2	287	2	0	4	213	4	523	

Traffic Counts - Heavy Vehicles, Bicycles on Road, and Pedestrians/Bicycles in Crosswalk

Interval Start Time	Heavy Vehicles					Interval Start Time	Bicycles on Roadway					Interval Start Time	Pedestrians/Bicycles on Crosswalk				
	EB	NB	WB	SB	Total		EB	NB	WB	SB	Total		EB	NB	WB	SB	Total
4:00 PM	0	0	0	0	0	4:00 PM	0	0	0	0	0	4:00 PM	2	0	2	0	4
4:15 PM	0	0	0	0	0	4:15 PM	0	1	0	0	1	4:15 PM	3	1	0	0	4
4:30 PM	0	1	0	0	1	4:30 PM	0	1	0	0	1	4:30 PM	2	0	0	0	2
4:45 PM	0	0	0	0	0	4:45 PM	0	0	0	0	0	4:45 PM	0	0	0	0	0
5:00 PM	0	0	0	1	1	5:00 PM	0	0	0	0	0	5:00 PM	0	2	0	0	2
5:15 PM	0	0	0	0	0	5:15 PM	0	0	0	0	0	5:15 PM	1	0	1	0	2
5:30 PM	0	0	0	0	0	5:30 PM	0	0	0	0	0	5:30 PM	4	0	0	0	4
5:45 PM	0	0	0	0	0	5:45 PM	0	0	0	0	0	5:45 PM	3	0	3	0	6
Count Total	0	1	0	1	2	Count Total	0	2	0	0	2	Count Total	15	3	6	0	24
Peak Hour	0	0	0	1	1	Peak Hour	0	0	0	0	0	Peak Hour	8	2	4	0	14

Peak Hour

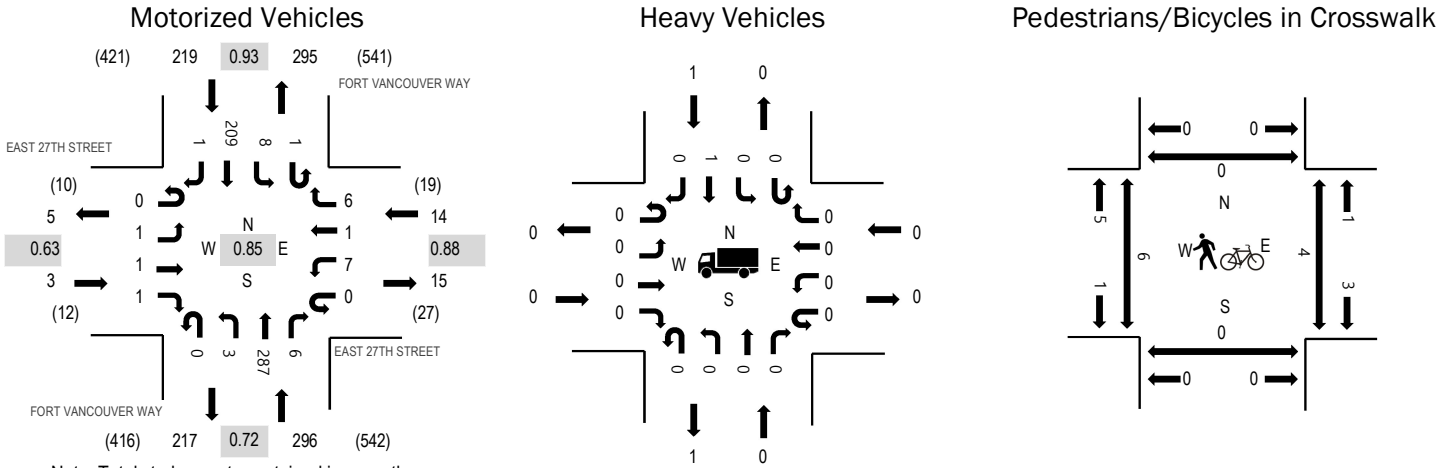

Note: Total study counts contained in parentheses.

	HV%	PHF
EB	0.0%	0.63
WB	0.0%	0.88
NB	0.0%	0.72
SB	0.5%	0.93
All	0.2%	0.85

Traffic Counts - Motorized Vehicles

Interval Start Time	EAST 27TH STREET Eastbound				EAST 27TH STREET Westbound				FORT VANCOUVER WAY Northbound				FORT VANCOUVER WAY Southbound				Total	Rolling Hour
	U-Turn	Left	Thru	Right	U-Turn	Left	Thru	Right	U-Turn	Left	Thru	Right	U-Turn	Left	Thru	Right		
4:00 PM	0	0	0	0	0	1	1	1	0	0	75	2	0	2	44	0	126	465
4:15 PM	0	3	0	1	0	0	0	0	0	0	50	1	0	1	42	1	99	495
4:30 PM	0	2	0	2	0	1	0	1	0	1	56	2	0	2	49	1	117	528
4:45 PM	0	1	0	0	0	2	0	2	0	0	62	1	1	1	53	0	123	532
5:00 PM	0	0	0	1	0	3	0	1	0	1	97	5	0	5	43	0	156	529
5:15 PM	0	0	1	0	0	1	1	2	0	1	69	0	0	1	55	1	132	
5:30 PM	0	0	0	0	0	1	0	1	0	1	59	0	0	1	58	0	121	
5:45 PM	0	1	0	0	0	0	0	0	0	1	57	1	0	1	59	0	120	
Count Total	0	7	1	4	0	9	2	8	0	5	525	12	1	14	403	3	994	
Peak Hour	0	1	1	1	0	7	1	6	0	3	287	6	1	8	209	1	532	

Traffic Counts - Heavy Vehicles, Bicycles on Road, and Pedestrians/Bicycles in Crosswalk

Interval Start Time	Heavy Vehicles					Interval Start Time	Bicycles on Roadway					Interval Start Time	Pedestrians/Bicycles on Crosswalk				
	EB	NB	WB	SB	Total		EB	NB	WB	SB	Total		EB	NB	WB	SB	Total
4:00 PM	0	0	0	0	0	4:00 PM	0	0	0	0	0	4:00 PM	3	1	3	0	7
4:15 PM	0	0	0	0	0	4:15 PM	0	1	0	0	1	4:15 PM	2	0	0	0	2
4:30 PM	0	1	0	0	1	4:30 PM	0	1	0	0	1	4:30 PM	2	0	1	1	4
4:45 PM	0	0	0	0	0	4:45 PM	0	0	0	0	0	4:45 PM	0	0	2	0	2
5:00 PM	0	0	0	1	1	5:00 PM	0	0	0	0	0	5:00 PM	0	0	1	0	1
5:15 PM	0	0	0	0	0	5:15 PM	0	0	0	0	0	5:15 PM	2	0	1	0	3
5:30 PM	0	0	0	0	0	5:30 PM	0	0	0	0	0	5:30 PM	4	0	0	0	4
5:45 PM	0	0	0	0	0	5:45 PM	0	0	0	0	0	5:45 PM	3	0	3	0	6
Count Total	0	1	0	1	2	Count Total	0	2	0	0	2	Count Total	16	1	11	1	29
Peak Hour	0	0	0	1	1	Peak Hour	0	0	0	0	0	Peak Hour	6	0	4	0	10

Location: 4 FORT VANCOUVER WAY & EAST 28TH STREET PM

Date: Thursday, February 29, 2024

Peak Hour: 04:45 PM - 05:45 PM

Peak 15-Minutes: 05:00 PM - 05:15 PM

Peak Hour

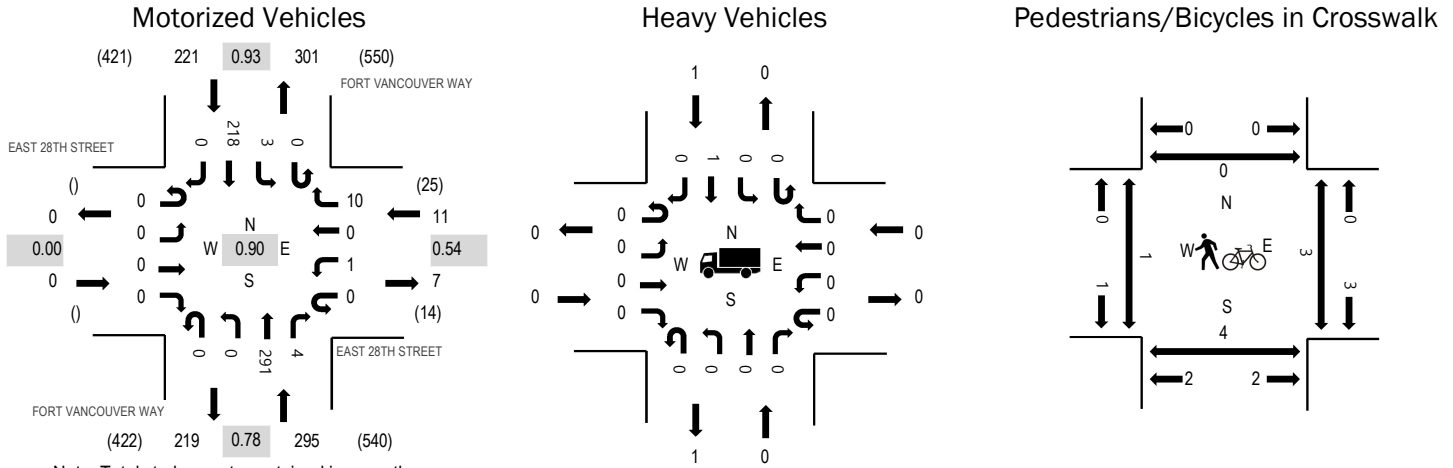

Note: Total study counts contained in parentheses.

	HV%	PHF
EB	0.0%	0.00
WB	0.0%	0.54
NB	0.0%	0.78
SB	0.5%	0.93
All	0.2%	0.90

Traffic Counts - Motorized Vehicles

Interval Start Time	EAST 28TH STREET Eastbound				EAST 28TH STREET Westbound				FORT VANCOUVER WAY Northbound				FORT VANCOUVER WAY Southbound				Total	Rolling Hour
	U-Turn	Left	Thru	Right	U-Turn	Left	Thru	Right	U-Turn	Left	Thru	Right	U-Turn	Left	Thru	Right		
4:00 PM	0	0	0	0	0	4	0	2	0	0	73	1	0	2	42	0	124	463
4:15 PM	0	0	0	0	0	1	0	1	0	0	53	1	0	0	43	0	99	485
4:30 PM	0	0	0	0	0	1	0	3	0	0	59	1	0	2	51	0	117	522
4:45 PM	0	0	0	0	0	0	0	1	0	0	64	1	0	1	56	0	123	527
5:00 PM	0	0	0	0	0	0	0	3	0	0	93	2	0	0	48	0	146	523
5:15 PM	0	0	0	0	0	0	0	4	0	0	73	1	0	2	56	0	136	
5:30 PM	0	0	0	0	0	1	0	2	0	0	61	0	0	0	58	0	122	
5:45 PM	0	0	0	0	0	1	0	1	0	0	57	0	0	0	60	0	119	
Count Total	0	0	0	0	0	8	0	17	0	0	533	7	0	7	414	0	986	
Peak Hour	0	0	0	0	0	1	0	10	0	0	291	4	0	3	218	0	527	

Traffic Counts - Heavy Vehicles, Bicycles on Road, and Pedestrians/Bicycles in Crosswalk

Interval Start Time	Heavy Vehicles					Interval Start Time	Bicycles on Roadway					Interval Start Time	Pedestrians/Bicycles on Crosswalk				
	EB	NB	WB	SB	Total		EB	NB	WB	SB	Total		EB	NB	WB	SB	Total
4:00 PM	0	0	0	0	0	4:00 PM	0	0	0	0	0	4:00 PM	1	0	1	0	2
4:15 PM	0	0	0	0	0	4:15 PM	0	1	0	0	1	4:15 PM	2	0	1	4	7
4:30 PM	0	1	0	0	1	4:30 PM	0	1	0	0	1	4:30 PM	1	0	1	0	2
4:45 PM	0	0	0	0	0	4:45 PM	0	0	0	0	0	4:45 PM	0	0	2	0	2
5:00 PM	0	0	0	1	1	5:00 PM	0	0	0	0	0	5:00 PM	0	2	0	0	2
5:15 PM	0	0	0	0	0	5:15 PM	0	0	0	0	0	5:15 PM	0	2	1	0	3
5:30 PM	0	0	0	0	0	5:30 PM	0	0	0	0	0	5:30 PM	1	0	0	0	1
5:45 PM	0	0	0	0	0	5:45 PM	0	0	0	0	0	5:45 PM	3	3	1	1	8
Count Total	0	1	0	1	2	Count Total	0	2	0	0	2	Count Total	8	7	7	5	27
Peak Hour	0	0	0	1	1	Peak Hour	0	0	0	0	0	Peak Hour	1	4	3	0	8

Vehicle Volume Report - Hourly

Site Description: FT VANCOUVER WAY S.O E 28TH ST
 Site Number: 5
 Start Date: 2/29/2024
 End Date: 2/29/2024

Time	Monday			Tuesday			Wednesday			Thursday			Friday			Saturday			Sunday			3 Day Avg		5 Day Avg		7 Day Avg	
	3/4/24			3/5/24			3/6/24			2/29/24			3/1/24			3/2/24			3/3/24			Tue-Thu		Mon-Fri		Mon-Sun	
	NB	SB	Total	NB	SB	Total	NB	SB	Total	NB	SB	Total	NB	SB	Total	NB	SB	Total	NB	SB	Total	NB	SB	NB	SB	NB	SB
12:00 AM	-	-	-	-	-	-	-	-	-	15	13	28	-	-	-	-	-	-	-	-	-	-	-	-	-	-	-
1:00 AM	-	-	-	-	-	-	-	-	-	9	12	21	-	-	-	-	-	-	-	-	-	-	-	-	-	-	-
2:00 AM	-	-	-	-	-	-	-	-	-	7	10	17	-	-	-	-	-	-	-	-	-	-	-	-	-	-	-
3:00 AM	-	-	-	-	-	-	-	-	-	7	5	12	-	-	-	-	-	-	-	-	-	-	-	-	-	-	-
4:00 AM	-	-	-	-	-	-	-	-	-	13	16	29	-	-	-	-	-	-	-	-	-	-	-	-	-	-	-
5:00 AM	-	-	-	-	-	-	-	-	-	25	58	83	-	-	-	-	-	-	-	-	-	-	-	-	-	-	-
6:00 AM	-	-	-	-	-	-	-	-	-	38	195	233	-	-	-	-	-	-	-	-	-	-	-	-	-	-	-
7:00 AM	-	-	-	-	-	-	-	-	-	97	438	535	-	-	-	-	-	-	-	-	-	-	-	-	-	-	-
8:00 AM	-	-	-	-	-	-	-	-	-	161	590	751	-	-	-	-	-	-	-	-	-	-	-	-	-	-	-
9:00 AM	-	-	-	-	-	-	-	-	-	150	415	565	-	-	-	-	-	-	-	-	-	-	-	-	-	-	-
10:00 AM	-	-	-	-	-	-	-	-	-	178	307	485	-	-	-	-	-	-	-	-	-	-	-	-	-	-	-
11:00 AM	-	-	-	-	-	-	-	-	-	231	229	460	-	-	-	-	-	-	-	-	-	-	-	-	-	-	-
12:00 PM	-	-	-	-	-	-	-	-	-	260	248	508	-	-	-	-	-	-	-	-	-	-	-	-	-	-	-
1:00 PM	-	-	-	-	-	-	-	-	-	189	169	358	-	-	-	-	-	-	-	-	-	-	-	-	-	-	-
2:00 PM	-	-	-	-	-	-	-	-	-	276	220	496	-	-	-	-	-	-	-	-	-	-	-	-	-	-	-
3:00 PM	-	-	-	-	-	-	-	-	-	314	234	548	-	-	-	-	-	-	-	-	-	-	-	-	-	-	-
4:00 PM	-	-	-	-	-	-	-	-	-	251	212	463	-	-	-	-	-	-	-	-	-	-	-	-	-	-	-
5:00 PM	-	-	-	-	-	-	-	-	-	288	229	517	-	-	-	-	-	-	-	-	-	-	-	-	-	-	-
6:00 PM	-	-	-	-	-	-	-	-	-	236	172	408	-	-	-	-	-	-	-	-	-	-	-	-	-	-	-
7:00 PM	-	-	-	-	-	-	-	-	-	119	89	208	-	-	-	-	-	-	-	-	-	-	-	-	-	-	-
8:00 PM	-	-	-	-	-	-	-	-	-	107	85	192	-	-	-	-	-	-	-	-	-	-	-	-	-	-	-
9:00 PM	-	-	-	-	-	-	-	-	-	94	65	159	-	-	-	-	-	-	-	-	-	-	-	-	-	-	-
10:00 PM	-	-	-	-	-	-	-	-	-	53	40	93	-	-	-	-	-	-	-	-	-	-	-	-	-	-	-
11:00 PM	-	-	-	-	-	-	-	-	-	23	34	57	-	-	-	-	-	-	-	-	-	-	-	-	-	-	-
6:00 AM - 9:00 AM	-	-	-	-	-	-	-	-	-	296	1223	1519	-	-	-	-	-	-	-	-	-	-	-	-	-	-	-
3:00 PM - 6:00 PM	-	-	-	-	-	-	-	-	-	853	675	1528	-	-	-	-	-	-	-	-	-	-	-	-	-	-	-
6:00 AM - 7:00 PM	-	-	-	-	-	-	-	-	-	2669	3658	6327	-	-	-	-	-	-	-	-	-	-	-	-	-	-	-
12:00 AM - 12:00 AM	-	-	-	-	-	-	-	-	-	3141	4085	7226	-	-	-	-	-	-	-	-	-	-	-	-	-	-	-
Percent	-	-	-	-	-	-	-	-	-	43.5%	56.5%	100.0%	-	-	-	-	-	-	-	-	-	-	-	-	-	-	-
AM Peak	-	-	-	-	-	-	-	-	-	8:00 AM	9:00 AM	-	-	-	-	-	-	-	-	-	-	-	-	-	-	-	-
PM Peak	-	-	-	-	-	-	-	-	-	3:00 PM	4:00 PM	-	-	-	-	-	-	-	-	-	-	-	-	-	-	-	-

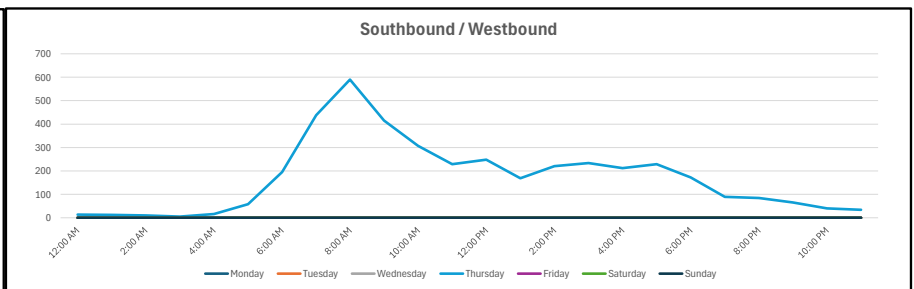
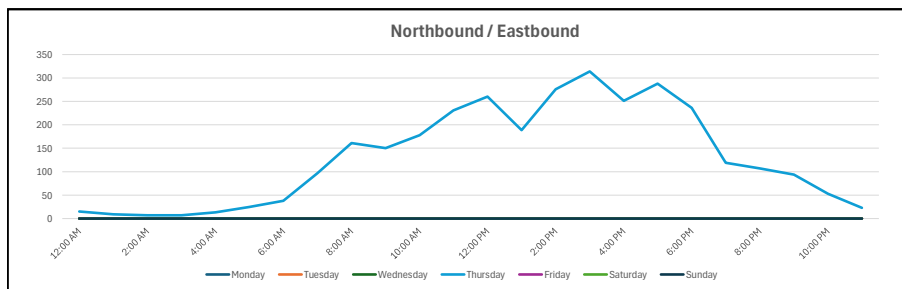

Vehicle Speed Report - Hourly

Site Description: FT VANCOUVER WAY S.O E 28TH ST
Site Number: 5
Start Date: 2/29/2024
End Date: 2/29/2024

Total Study Speed Summary		
	Northbound	Southbound
Average Speed	25.8 mph	25.8 mph
50th Percentile	26.2 mph	26.5 mph
85th Percentile	30.3 mph	30.8 mph
95th Percentile	32.8 mph	33.3 mph

Speed Range (MPH) - Total Study																					
	Total	0-10	10-15	15-20	20-25	25-30	30-35	35-40	40-45	45-50	50-55	55-60	60-65	65-70	70-75	75-80	80-85	85-90	90-95	95-100	100+
Northbound	3141	26	92	198	865	1439	453	61	4	1	0	2	0	0	0	0	0	0	0	0	0
Percent	100.0%	0.8%	2.9%	6.3%	27.5%	45.8%	14.4%	1.9%	0.1%	0.0%	0.0%	0.1%	0.0%	0.0%	0.0%	0.0%	0.0%	0.0%	0.0%	0.0%	0.0%
Southbound	4085	80	171	259	932	1812	750	70	9	1	0	1	0	0	0	0	0	0	0	0	0
Percent	100.0%	2.0%	4.2%	6.3%	22.8%	44.4%	18.4%	1.7%	0.2%	0.0%	0.0%	0.0%	0.0%	0.0%	0.0%	0.0%	0.0%	0.0%	0.0%	0.0%	0.0%
Total	7226	106	263	457	1797	3251	1203	131	13	2	0	3	0	0	0	0	0	0	0	0	0
Percent	100.0%	1.5%	3.6%	6.3%	24.9%	45.0%	16.6%	1.8%	0.2%	0.0%	0.0%	0.0%	0.0%	0.0%	0.0%	0.0%	0.0%	0.0%	0.0%	0.0%	0.0%

Site Description: FT VANCOUVER WAY S.O E 28TH ST
 Site Number: 5
 Start Date: 2/29/2024
 End Date: 2/29/2024

Vehicle Speed Report (Northbound - 02/29/2024)

Thursday		Northbound																			
2/29/24	Total	0-10	10-15	15-20	20-25	25-30	30-35	35-40	40-45	45-50	50-55	55-60	60-65	65-70	70-75	75-80	80-85	85-90	90-95	95-100	100+
12:00 AM	15	0	0	1	4	4	5	1	0	0	0	0	0	0	0	0	0	0	0	0	0
1:00 AM	9	0	0	1	1	6	1	0	0	0	0	0	0	0	0	0	0	0	0	0	0
2:00 AM	7	0	0	0	1	0	3	3	0	0	0	0	0	0	0	0	0	0	0	0	0
3:00 AM	7	0	0	0	0	3	4	0	0	0	0	0	0	0	0	0	0	0	0	0	0
4:00 AM	13	0	1	0	2	5	5	0	0	0	0	0	0	0	0	0	0	0	0	0	0
5:00 AM	25	0	1	1	8	10	5	0	0	0	0	0	0	0	0	0	0	0	0	0	0
6:00 AM	38	1	0	2	7	18	9	0	1	0	0	0	0	0	0	0	0	0	0	0	0
7:00 AM	97	2	2	5	23	47	16	2	0	0	0	0	0	0	0	0	0	0	0	0	0
8:00 AM	161	1	3	7	38	75	27	7	1	0	0	2	0	0	0	0	0	0	0	0	0
9:00 AM	150	0	2	10	38	79	20	1	0	0	0	0	0	0	0	0	0	0	0	0	0
10:00 AM	178	1	4	4	32	102	28	6	1	0	0	0	0	0	0	0	0	0	0	0	0
11:00 AM	231	2	14	19	60	94	32	10	0	0	0	0	0	0	0	0	0	0	0	0	0
12:00 PM	260	3	8	19	86	113	28	3	0	0	0	0	0	0	0	0	0	0	0	0	0
1:00 PM	189	1	4	11	59	85	25	3	1	0	0	0	0	0	0	0	0	0	0	0	0
2:00 PM	276	3	5	19	102	117	28	2	0	0	0	0	0	0	0	0	0	0	0	0	0
3:00 PM	314	8	25	35	93	112	37	4	0	0	0	0	0	0	0	0	0	0	0	0	0
4:00 PM	251	0	8	11	82	122	24	4	0	0	0	0	0	0	0	0	0	0	0	0	0
5:00 PM	288	2	5	22	90	132	36	1	0	0	0	0	0	0	0	0	0	0	0	0	0
6:00 PM	236	2	7	20	77	104	23	2	0	1	0	0	0	0	0	0	0	0	0	0	0
7:00 PM	119	0	2	4	20	68	23	2	0	0	0	0	0	0	0	0	0	0	0	0	0
8:00 PM	107	0	0	5	19	60	18	5	0	0	0	0	0	0	0	0	0	0	0	0	0
9:00 PM	94	0	0	1	13	46	32	2	0	0	0	0	0	0	0	0	0	0	0	0	0
10:00 PM	53	0	1	0	8	24	18	2	0	0	0	0	0	0	0	0	0	0	0	0	0
11:00 PM	23	0	0	1	2	13	6	1	0	0	0	0	0	0	0	0	0	0	0	0	0
6:00 AM - 9:00 AM	296	4	5	14	68	140	52	9	2	0	0	2	0	0	0	0	0	0	0	0	0
3:00 PM - 6:00 PM	853	10	38	68	265	366	97	9	0	0	0	0	0	0	0	0	0	0	0	0	0
6:00 AM - 7:00 PM	2669	26	87	184	787	1200	333	45	4	1	0	2	0	0	0	0	0	0	0	0	0
12:00 AM - 12:00 AM	3141	26	92	198	865	1439	453	61	4	1	0	2	0	0	0	0	0	0	0	0	0
Percent	100%	0.8%	2.9%	6.3%	27.5%	45.8%	14.4%	1.9%	0.1%	0.0%	0.0%	0.1%	0.0%	0.0%	0.0%	0.0%	0.0%	0.0%	0.0%	0.0%	0.0%
50th Percentile	26.2 mph																				
85th Percentile	30.3 mph																				
95th Percentile	32.8 mph																				

Site Description: FT VANCOUVER WAY S.O E 28TH ST
 Site Number: 5
 Start Date: 2/29/2024
 End Date: 2/29/2024

Vehicle Speed Report (Southbound - 02/29/2024)

Thursday		Southbound																			
2/29/24	Total	0-10	10-15	15-20	20-25	25-30	30-35	35-40	40-45	45-50	50-55	55-60	60-65	65-70	70-75	75-80	80-85	85-90	90-95	95-100	100+
12:00 AM	13	0	0	0	4	7	2	0	0	0	0	0	0	0	0	0	0	0	0	0	0
1:00 AM	12	0	0	0	2	3	7	0	0	0	0	0	0	0	0	0	0	0	0	0	0
2:00 AM	10	1	0	2	0	4	3	0	0	0	0	0	0	0	0	0	0	0	0	0	0
3:00 AM	5	0	0	0	1	1	3	0	0	0	0	0	0	0	0	0	0	0	0	0	0
4:00 AM	16	0	0	1	1	10	4	0	0	0	0	0	0	0	0	0	0	0	0	0	0
5:00 AM	58	0	1	1	10	25	18	2	1	0	0	0	0	0	0	0	0	0	0	0	0
6:00 AM	195	1	0	1	18	95	70	7	2	1	0	0	0	0	0	0	0	0	0	0	0
7:00 AM	438	8	23	36	64	186	112	7	2	0	0	0	0	0	0	0	0	0	0	0	0
8:00 AM	590	32	94	96	143	186	34	4	0	0	0	1	0	0	0	0	0	0	0	0	0
9:00 AM	415	3	29	45	108	168	59	3	0	0	0	0	0	0	0	0	0	0	0	0	0
10:00 AM	307	4	1	16	52	164	61	9	0	0	0	0	0	0	0	0	0	0	0	0	0
11:00 AM	229	3	3	3	58	110	44	8	0	0	0	0	0	0	0	0	0	0	0	0	0
12:00 PM	248	3	6	10	64	121	41	2	1	0	0	0	0	0	0	0	0	0	0	0	0
1:00 PM	169	3	0	4	51	81	25	5	0	0	0	0	0	0	0	0	0	0	0	0	0
2:00 PM	220	5	1	5	78	97	33	1	0	0	0	0	0	0	0	0	0	0	0	0	0
3:00 PM	234	6	3	10	36	113	63	3	0	0	0	0	0	0	0	0	0	0	0	0	0
4:00 PM	212	4	3	5	72	86	33	8	1	0	0	0	0	0	0	0	0	0	0	0	0
5:00 PM	229	5	3	7	56	110	44	3	1	0	0	0	0	0	0	0	0	0	0	0	0
6:00 PM	172	1	0	7	44	78	36	5	1	0	0	0	0	0	0	0	0	0	0	0	0
7:00 PM	89	1	1	1	22	46	18	0	0	0	0	0	0	0	0	0	0	0	0	0	0
8:00 PM	85	0	1	2	16	51	14	1	0	0	0	0	0	0	0	0	0	0	0	0	0
9:00 PM	65	0	1	4	14	32	12	2	0	0	0	0	0	0	0	0	0	0	0	0	0
10:00 PM	40	0	0	2	9	20	9	0	0	0	0	0	0	0	0	0	0	0	0	0	0
11:00 PM	34	0	1	1	9	18	5	0	0	0	0	0	0	0	0	0	0	0	0	0	0
6:00 AM - 9:00 AM	1223	41	117	133	225	467	216	18	4	1	0	1	0	0	0	0	0	0	0	0	0
3:00 PM - 6:00 PM	675	15	9	22	164	309	140	14	2	0	0	0	0	0	0	0	0	0	0	0	0
6:00 AM - 7:00 PM	3658	78	166	245	844	1595	655	65	8	1	0	1	0	0	0	0	0	0	0	0	0
12:00 AM - 12:00 AM	4085	80	171	259	932	1812	750	70	9	1	0	1	0	0	0	0	0	0	0	0	0
Percent	100%	2.0%	4.2%	6.3%	22.8%	44.4%	18.4%	1.7%	0.2%	0.0%	0.0%	0.0%	0.0%	0.0%	0.0%	0.0%	0.0%	0.0%	0.0%	0.0%	0.0%
50th Percentile	26.5 mph																				
85th Percentile	30.8 mph																				
95th Percentile	33.3 mph																				

Vehicle Volume Report - Hourly

Site Description: FT VANCOUVER WAY N.O E 4TH PLAIN BLVD
 Site Number: 6
 Start Date: 2/29/2024
 End Date: 2/29/2024

Time	Monday			Tuesday			Wednesday			Thursday			Friday			Saturday			Sunday			3 Day Avg		5 Day Avg		7 Day Avg	
	3/4/24			3/5/24			3/6/24			2/29/24			3/1/24			3/2/24			3/3/24			Tue-Thu		Mon-Fri		Mon-Sun	
	NB	SB	Total	NB	SB	Total	NB	SB	Total	NB	SB	Total	NB	SB	Total	NB	SB	Total	NB	SB	Total	NB	SB	NB	SB	NB	SB
12:00 AM	-	-	-	-	-	-	-	-	-	34	10	44	-	-	-	-	-	-	-	-	-	-	-	-	-	-	
1:00 AM	-	-	-	-	-	-	-	-	-	20	5	25	-	-	-	-	-	-	-	-	-	-	-	-	-	-	
2:00 AM	-	-	-	-	-	-	-	-	-	13	8	21	-	-	-	-	-	-	-	-	-	-	-	-	-	-	
3:00 AM	-	-	-	-	-	-	-	-	-	9	8	17	-	-	-	-	-	-	-	-	-	-	-	-	-	-	
4:00 AM	-	-	-	-	-	-	-	-	-	19	12	31	-	-	-	-	-	-	-	-	-	-	-	-	-	-	
5:00 AM	-	-	-	-	-	-	-	-	-	28	36	64	-	-	-	-	-	-	-	-	-	-	-	-	-	-	
6:00 AM	-	-	-	-	-	-	-	-	-	63	140	203	-	-	-	-	-	-	-	-	-	-	-	-	-	-	
7:00 AM	-	-	-	-	-	-	-	-	-	120	224	344	-	-	-	-	-	-	-	-	-	-	-	-	-	-	
8:00 AM	-	-	-	-	-	-	-	-	-	206	377	583	-	-	-	-	-	-	-	-	-	-	-	-	-	-	
9:00 AM	-	-	-	-	-	-	-	-	-	181	220	401	-	-	-	-	-	-	-	-	-	-	-	-	-	-	
10:00 AM	-	-	-	-	-	-	-	-	-	202	236	438	-	-	-	-	-	-	-	-	-	-	-	-	-	-	
11:00 AM	-	-	-	-	-	-	-	-	-	272	205	477	-	-	-	-	-	-	-	-	-	-	-	-	-	-	
12:00 PM	-	-	-	-	-	-	-	-	-	321	230	551	-	-	-	-	-	-	-	-	-	-	-	-	-	-	
1:00 PM	-	-	-	-	-	-	-	-	-	217	181	398	-	-	-	-	-	-	-	-	-	-	-	-	-	-	
2:00 PM	-	-	-	-	-	-	-	-	-	321	200	521	-	-	-	-	-	-	-	-	-	-	-	-	-	-	
3:00 PM	-	-	-	-	-	-	-	-	-	345	201	546	-	-	-	-	-	-	-	-	-	-	-	-	-	-	
4:00 PM	-	-	-	-	-	-	-	-	-	267	165	432	-	-	-	-	-	-	-	-	-	-	-	-	-	-	
5:00 PM	-	-	-	-	-	-	-	-	-	278	187	465	-	-	-	-	-	-	-	-	-	-	-	-	-	-	
6:00 PM	-	-	-	-	-	-	-	-	-	245	142	387	-	-	-	-	-	-	-	-	-	-	-	-	-	-	
7:00 PM	-	-	-	-	-	-	-	-	-	147	77	224	-	-	-	-	-	-	-	-	-	-	-	-	-	-	
8:00 PM	-	-	-	-	-	-	-	-	-	130	83	213	-	-	-	-	-	-	-	-	-	-	-	-	-	-	
9:00 PM	-	-	-	-	-	-	-	-	-	106	49	155	-	-	-	-	-	-	-	-	-	-	-	-	-	-	
10:00 PM	-	-	-	-	-	-	-	-	-	73	27	100	-	-	-	-	-	-	-	-	-	-	-	-	-	-	
11:00 PM	-	-	-	-	-	-	-	-	-	24	27	51	-	-	-	-	-	-	-	-	-	-	-	-	-	-	
6:00 AM - 9:00 AM	-	-	-	-	-	-	-	-	-	389	741	1130	-	-	-	-	-	-	-	-	-	-	-	-	-	-	
3:00 PM - 6:00 PM	-	-	-	-	-	-	-	-	-	890	553	1443	-	-	-	-	-	-	-	-	-	-	-	-	-	-	
6:00 AM - 7:00 PM	-	-	-	-	-	-	-	-	-	3038	2708	5746	-	-	-	-	-	-	-	-	-	-	-	-	-	-	
12:00 AM - 12:00 AM	-	-	-	-	-	-	-	-	-	3641	3050	6691	-	-	-	-	-	-	-	-	-	-	-	-	-	-	
Percent	-	-	-	-	-	-	-	-	-	54.4%	45.6%	100.0%	-	-	-	-	-	-	-	-	-	-	-	-	-	-	
AM Peak	-	-	-	-	-	-	-	-	-	8:00 AM	9:00 AM	-	-	-	-	-	-	-	-	-	-	-	-	-	-	-	
PM Peak	-	-	-	-	-	-	-	-	-	12:00 PM	1:00 PM	-	-	-	-	-	-	-	-	-	-	-	-	-	-	-	

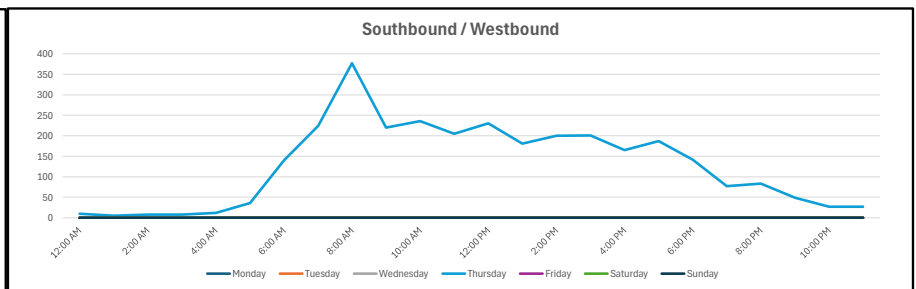
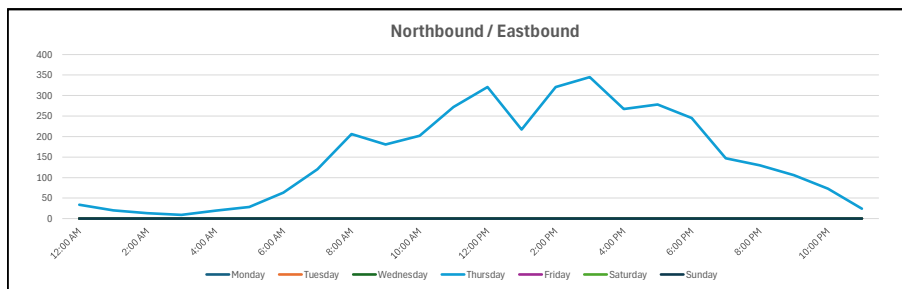

Vehicle Speed Report - Hourly

Site Description: FT VANCOUVER WAY N.O.E 4TH PLA
Site Number: 6
Start Date: 2/29/2024
End Date: 2/29/2024

Total Study Speed Summary		
	Northbound	Southbound
Average Speed	22.3 mph	18.2 mph
50th Percentile	22.6 mph	17.5 mph
85th Percentile	27.2 mph	23.5 mph
95th Percentile	29.8 mph	29.4 mph

Speed Range (MPH) - Total Study																					
	Total	0-10	10-15	15-20	20-25	25-30	30-35	35-40	40-45	45-50	50-55	55-60	60-65	65-70	70-75	75-80	80-85	85-90	90-95	95-100	100+
Northbound	3641	63	211	811	1434	955	156	9	2	0	0	0	0	0	0	0	0	0	0	0	0
Percent	100.0%	1.7%	5.8%	22.3%	39.4%	26.2%	4.3%	0.2%	0.1%	0.0%	0.0%	0.0%	0.0%	0.0%	0.0%	0.0%	0.0%	0.0%	0.0%	0.0%	0.0%
Southbound	3050	140	748	1194	627	215	102	20	3	1	0	0	0	0	0	0	0	0	0	0	0
Percent	100.0%	4.6%	24.5%	39.1%	20.6%	7.0%	3.3%	0.7%	0.1%	0.0%	0.0%	0.0%	0.0%	0.0%	0.0%	0.0%	0.0%	0.0%	0.0%	0.0%	0.0%
Total	6691	203	959	2005	2061	1170	258	29	5	1	0	0	0	0	0	0	0	0	0	0	0
Percent	100.0%	3.0%	14.3%	30.0%	30.8%	17.5%	3.9%	0.4%	0.1%	0.0%	0.0%	0.0%	0.0%	0.0%	0.0%	0.0%	0.0%	0.0%	0.0%	0.0%	0.0%

Site Description: FT VANCOUVER WAY N.O E 4TH PLA
 Site Number: 6
 Start Date: 2/29/2024
 End Date: 2/29/2024

Vehicle Speed Report (Northbound - 02/29/2024)

Thursday		Northbound																			
2/29/24	Total	0-10	10-15	15-20	20-25	25-30	30-35	35-40	40-45	45-50	50-55	55-60	60-65	65-70	70-75	75-80	80-85	85-90	90-95	95-100	100+
12:00 AM	34	0	6	16	6	3	3	0	0	0	0	0	0	0	0	0	0	0	0	0	0
1:00 AM	20	1	6	8	4	1	0	0	0	0	0	0	0	0	0	0	0	0	0	0	0
2:00 AM	13	0	1	8	4	0	0	0	0	0	0	0	0	0	0	0	0	0	0	0	0
3:00 AM	9	0	1	6	2	0	0	0	0	0	0	0	0	0	0	0	0	0	0	0	0
4:00 AM	19	0	1	6	6	5	1	0	0	0	0	0	0	0	0	0	0	0	0	0	0
5:00 AM	28	1	7	6	10	3	1	0	0	0	0	0	0	0	0	0	0	0	0	0	0
6:00 AM	63	0	3	17	28	14	1	0	0	0	0	0	0	0	0	0	0	0	0	0	0
7:00 AM	120	0	12	34	44	25	5	0	0	0	0	0	0	0	0	0	0	0	0	0	0
8:00 AM	206	1	9	57	82	48	8	1	0	0	0	0	0	0	0	0	0	0	0	0	0
9:00 AM	181	1	13	44	75	39	9	0	0	0	0	0	0	0	0	0	0	0	0	0	0
10:00 AM	202	2	8	52	68	66	4	1	1	0	0	0	0	0	0	0	0	0	0	0	0
11:00 AM	272	9	16	58	109	65	15	0	0	0	0	0	0	0	0	0	0	0	0	0	0
12:00 PM	321	3	17	83	133	76	9	0	0	0	0	0	0	0	0	0	0	0	0	0	0
1:00 PM	217	5	17	57	82	43	12	0	1	0	0	0	0	0	0	0	0	0	0	0	0
2:00 PM	321	3	7	58	156	85	11	1	0	0	0	0	0	0	0	0	0	0	0	0	0
3:00 PM	345	6	20	61	137	98	20	3	0	0	0	0	0	0	0	0	0	0	0	0	0
4:00 PM	267	3	4	39	110	103	7	1	0	0	0	0	0	0	0	0	0	0	0	0	0
5:00 PM	278	8	6	44	119	82	17	2	0	0	0	0	0	0	0	0	0	0	0	0	0
6:00 PM	245	5	12	50	90	79	9	0	0	0	0	0	0	0	0	0	0	0	0	0	0
7:00 PM	147	3	13	29	61	37	4	0	0	0	0	0	0	0	0	0	0	0	0	0	0
8:00 PM	130	5	12	22	40	42	9	0	0	0	0	0	0	0	0	0	0	0	0	0	0
9:00 PM	106	2	6	27	32	32	7	0	0	0	0	0	0	0	0	0	0	0	0	0	0
10:00 PM	73	4	10	20	29	8	2	0	0	0	0	0	0	0	0	0	0	0	0	0	0
11:00 PM	24	1	4	9	7	1	2	0	0	0	0	0	0	0	0	0	0	0	0	0	0
6:00 AM - 9:00 AM	389	1	24	108	154	87	14	1	0	0	0	0	0	0	0	0	0	0	0	0	0
3:00 PM - 6:00 PM	890	17	30	144	366	283	44	6	0	0	0	0	0	0	0	0	0	0	0	0	0
6:00 AM - 7:00 PM	3038	46	144	654	1233	823	127	9	2	0	0	0	0	0	0	0	0	0	0	0	0
12:00 AM - 12:00 AM	3641	63	211	811	1434	955	156	9	2	0	0	0	0	0	0	0	0	0	0	0	0
Percent	100%	1.7%	5.8%	22.3%	39.4%	26.2%	4.3%	0.2%	0.1%	0.0%	0.0%	0.0%	0.0%	0.0%	0.0%	0.0%	0.0%	0.0%	0.0%	0.0%	0.0%
50th Percentile	22.6 mph																				
85th Percentile	27.2 mph																				
95th Percentile	29.8 mph																				

Site Description: FT VANCOUVER WAY N.O E 4TH PLA
 Site Number: 6
 Start Date: 2/29/2024
 End Date: 2/29/2024

Vehicle Speed Report (Southbound - 02/29/2024)

Thursday		Southbound																			
2/29/24	Total	0-10	10-15	15-20	20-25	25-30	30-35	35-40	40-45	45-50	50-55	55-60	60-65	65-70	70-75	75-80	80-85	85-90	90-95	95-100	100+
12:00 AM	10	0	2	6	1	1	0	0	0	0	0	0	0	0	0	0	0	0	0	0	0
1:00 AM	5	0	1	3	1	0	0	0	0	0	0	0	0	0	0	0	0	0	0	0	0
2:00 AM	8	1	2	2	2	1	0	0	0	0	0	0	0	0	0	0	0	0	0	0	0
3:00 AM	8	0	2	3	3	0	0	0	0	0	0	0	0	0	0	0	0	0	0	0	0
4:00 AM	12	0	2	3	3	3	1	0	0	0	0	0	0	0	0	0	0	0	0	0	0
5:00 AM	36	1	3	14	9	7	2	0	0	0	0	0	0	0	0	0	0	0	0	0	0
6:00 AM	140	3	17	38	41	24	12	4	0	1	0	0	0	0	0	0	0	0	0	0	0
7:00 AM	224	10	49	81	49	25	10	0	0	0	0	0	0	0	0	0	0	0	0	0	0
8:00 AM	377	20	106	134	82	29	6	0	0	0	0	0	0	0	0	0	0	0	0	0	0
9:00 AM	220	15	48	69	45	20	18	3	2	0	0	0	0	0	0	0	0	0	0	0	0
10:00 AM	236	16	61	84	53	16	4	2	0	0	0	0	0	0	0	0	0	0	0	0	0
11:00 AM	205	8	55	87	42	9	4	0	0	0	0	0	0	0	0	0	0	0	0	0	0
12:00 PM	230	13	51	102	39	12	10	3	0	0	0	0	0	0	0	0	0	0	0	0	0
1:00 PM	181	8	61	71	29	5	6	1	0	0	0	0	0	0	0	0	0	0	0	0	0
2:00 PM	200	14	51	92	29	9	5	0	0	0	0	0	0	0	0	0	0	0	0	0	0
3:00 PM	201	5	59	90	37	7	3	0	0	0	0	0	0	0	0	0	0	0	0	0	0
4:00 PM	165	4	48	75	23	7	5	3	0	0	0	0	0	0	0	0	0	0	0	0	0
5:00 PM	187	6	47	80	29	19	3	2	1	0	0	0	0	0	0	0	0	0	0	0	0
6:00 PM	142	6	29	67	28	6	5	1	0	0	0	0	0	0	0	0	0	0	0	0	0
7:00 PM	77	4	11	29	24	5	4	0	0	0	0	0	0	0	0	0	0	0	0	0	0
8:00 PM	83	3	25	22	27	5	1	0	0	0	0	0	0	0	0	0	0	0	0	0	0
9:00 PM	49	1	7	21	16	2	1	1	0	0	0	0	0	0	0	0	0	0	0	0	0
10:00 PM	27	1	8	10	7	1	0	0	0	0	0	0	0	0	0	0	0	0	0	0	0
11:00 PM	27	1	3	11	8	2	2	0	0	0	0	0	0	0	0	0	0	0	0	0	0
6:00 AM - 9:00 AM	741	33	172	253	172	78	28	4	0	1	0	0	0	0	0	0	0	0	0	0	0
3:00 PM - 6:00 PM	553	15	154	245	89	33	11	5	1	0	0	0	0	0	0	0	0	0	0	0	0
6:00 AM - 7:00 PM	2708	128	682	1070	526	188	91	19	3	1	0	0	0	0	0	0	0	0	0	0	0
12:00 AM - 12:00 AM	3050	140	748	1194	627	215	102	20	3	1	0	0	0	0	0	0	0	0	0	0	0
Percent	100%	4.6%	24.5%	39.1%	20.6%	7.0%	3.3%	0.7%	0.1%	0.0%	0.0%	0.0%	0.0%	0.0%	0.0%	0.0%	0.0%	0.0%	0.0%	0.0%	0.0%
50th Percentile	17.5 mph																				
85th Percentile	23.5 mph																				
95th Percentile	29.4 mph																				

Site Code: 15
ST JOHNS BLVD S.O 30TH ST

Start Time	14-Dec-23 Thu	NB	SB	Total						
12:00 AM		28	24	52						
01:00		12	10	22						
02:00		11	12	23						
03:00		7	11	18						
04:00		10	19	29						
05:00		48	70	118						
06:00		81	300	381						
07:00		127	579	706						
08:00		181	446	627						
09:00		174	253	427						
10:00		178	250	428						
11:00		252	227	479						
12:00 PM		262	283	545						
01:00		215	220	435						
02:00		282	249	531						
03:00		352	246	598						
04:00		379	212	591						
05:00		326	224	550						
06:00		203	182	385						
07:00		137	97	234						
08:00		137	97	234						
09:00		104	74	178						
10:00		88	43	131						
11:00		35	30	65						
Total		3629	4158	7787						
Percent		46.6%	53.4%							
AM Peak	-	11:00	07:00	-	-	-	-	-	-	07:00
Vol.	-	252	579	-	-	-	-	-	-	706
PM Peak	-	16:00	12:00	-	-	-	-	-	-	15:00
Vol.	-	379	283	-	-	-	-	-	-	598

Site Code: 15
ST JOHNS BLVD S.O 30TH ST

Start Time	15-Dec-23 Fri	NB	SB	Total						
12:00 AM		19	25	44						
01:00		15	15	30						
02:00		12	8	20						
03:00		10	12	22						
04:00		15	20	35						
05:00		45	56	101						
06:00		70	219	289						
07:00		123	356	479						
08:00		197	371	568						
09:00		206	277	483						
10:00		174	174	348						
11:00		210	198	408						
12:00 PM		226	241	467						
01:00		246	238	484						
02:00		291	234	525						
03:00		325	247	572						
04:00		340	235	575						
05:00		280	201	481						
06:00		214	202	416						
07:00		141	146	287						
08:00		145	117	262						
09:00		101	75	176						
10:00		74	56	130						
11:00		56	59	115						
Total		3535	3782	7317						
Percent		48.3%	51.7%							
AM Peak	-	11:00	08:00	-	-	-	-	-	-	08:00
Vol.	-	210	371	-	-	-	-	-	-	568
PM Peak	-	16:00	15:00	-	-	-	-	-	-	16:00
Vol.	-	340	247	-	-	-	-	-	-	575

Start Time	15-Dec-23 Fri	NB	SB	Total						
12:00 AM		54	58	112						
01:00		36	29	65						
02:00		29	20	49						
03:00		26	20	46						
04:00		48	44	92						
05:00		149	117	266						
06:00		221	309	530						
07:00		350	442	792						
08:00		355	402	757						
09:00		419	409	828						
10:00		416	314	730						
11:00		446	359	805						
12:00 PM		471	407	878						
01:00		430	339	769						
02:00		515	355	870						
03:00		551	364	915						
04:00		521	320	841						
05:00		520	327	847						
06:00		420	378	798						
07:00		301	296	597						
08:00		299	272	571						
09:00		192	174	366						
10:00		190	145	335						
11:00		116	143	259						
Total		7075	6043	13118						
Percent		53.9%	46.1%							
AM Peak	-	11:00	07:00	-	-	-	-	-	-	09:00
Vol.	-	446	442	-	-	-	-	-	-	828
PM Peak	-	15:00	12:00	-	-	-	-	-	-	15:00
Vol.	-	551	407	-	-	-	-	-	-	915

Site Code: 16
ST JOHNS BLVD N.O N.O 33RD ST

Start Time	16-Dec-23 Sat	NB	SB	Total						
12:00 AM		63	79	142						
01:00		44	43	87						
02:00		42	35	77						
03:00		24	31	55						
04:00		27	30	57						
05:00		60	57	117						
06:00		87	71	158						
07:00		126	117	243						
08:00		198	178	376						
09:00		353	289	642						
10:00		400	292	692						
11:00		415	306	721						
12:00 PM		432	351	783						
01:00		405	322	727						
02:00		423	386	809						
03:00		426	340	766						
04:00		437	370	807						
05:00		384	359	743						
06:00		315	312	627						
07:00		302	290	592						
08:00		235	241	476						
09:00		199	207	406						
10:00		154	164	318						
11:00		115	129	244						
Total		5666	4999	10665						
Percent		53.1%	46.9%							
AM Peak	-	11:00	11:00	-	-	-	-	-	-	11:00
Vol.	-	415	306	-	-	-	-	-	-	721
PM Peak	-	16:00	14:00	-	-	-	-	-	-	14:00
Vol.	-	437	386	-	-	-	-	-	-	809
Grand Total		18522	15054							33576
Percent		55.2%	44.8%							
ADT		ADT 11,192	AADT 11,192							

Start Time	16-Dec-23 Sat	SB										
12:00 AM		79										
01:00		46										
02:00		36										
03:00		16										
04:00		59										
05:00		82										
06:00		128										
07:00		211										
08:00		347										
09:00		463										
10:00		531										
11:00		602										
12:00 PM		583										
01:00		539										
02:00		538										
03:00		501										
04:00		524										
05:00		456										
06:00		343										
07:00		286										
08:00		240										
09:00		188										
10:00		160										
11:00		129										
Total		7087										
AM Peak	-	11:00	-	-	-	-	-	-	-	-	-	-
Vol.	-	602	-	-	-	-	-	-	-	-	-	-
PM Peak	-	12:00	-	-	-	-	-	-	-	-	-	-
Vol.	-	583	-	-	-	-	-	-	-	-	-	-
Grand Total		26198										
ADT		ADT 8,733	AADT 8,733									

Start Time	16-Dec-23 Sat	NB								
12:00 AM		81								
01:00		62								
02:00		56								
03:00		26								
04:00		27								
05:00		48								
06:00		97								
07:00		144								
08:00		243								
09:00		394								
10:00		486								
11:00		473								
12:00 PM		471								
01:00		561								
02:00		561								
03:00		615								
04:00		600								
05:00		558								
06:00		448								
07:00		400								
08:00		323								
09:00		268								
10:00		235								
11:00		172								
Total		7349								
AM Peak	-	10:00	-	-	-	-	-	-	-	-
Vol.	-	486	-	-	-	-	-	-	-	-
PM Peak	-	15:00	-	-	-	-	-	-	-	-
Vol.	-	615	-	-	-	-	-	-	-	-
Grand Total		26585								
ADT		ADT 8,862	AADT 8,862							

Start Time	16-Dec-23 Sat	SB										
12:00 AM		71										
01:00		40										
02:00		29										
03:00		18										
04:00		47										
05:00		53										
06:00		97										
07:00		157										
08:00		289										
09:00		384										
10:00		466										
11:00		485										
12:00 PM		499										
01:00		516										
02:00		479										
03:00		450										
04:00		431										
05:00		438										
06:00		324										
07:00		272										
08:00		223										
09:00		173										
10:00		150										
11:00		103										
Total		6194										
AM Peak	-	11:00	-	-	-	-	-	-	-	-	-	-
Vol.	-	485	-	-	-	-	-	-	-	-	-	-
PM Peak	-	13:00	-	-	-	-	-	-	-	-	-	-
Vol.	-	516	-	-	-	-	-	-	-	-	-	-
Grand Total		23102										
ADT		ADT 7,701	AADT 7,701									

Start Time	16-Dec-23 Sat	NB								
12:00 AM		74								
01:00		41								
02:00		30								
03:00		20								
04:00		21								
05:00		40								
06:00		85								
07:00		132								
08:00		236								
09:00		348								
10:00		414								
11:00		421								
12:00 PM		454								
01:00		501								
02:00		507								
03:00		470								
04:00		486								
05:00		453								
06:00		344								
07:00		313								
08:00		237								
09:00		196								
10:00		168								
11:00		116								
Total		6107								
AM Peak	-	11:00	-	-	-	-	-	-	-	-
Vol.	-	421	-	-	-	-	-	-	-	-
PM Peak	-	14:00	-	-	-	-	-	-	-	-
Vol.	-	507	-	-	-	-	-	-	-	-
Grand Total		22533								
ADT		ADT 7,511	AADT 7,511							

Start Time	16-Dec-23 Sat	SB								
12:00 AM		71								
01:00		36								
02:00		26								
03:00		13								
04:00		30								
05:00		33								
06:00		59								
07:00		112								
08:00		219								
09:00		320								
10:00		412								
11:00		475								
12:00 PM		488								
01:00		501								
02:00		471								
03:00		446								
04:00		463								
05:00		455								
06:00		299								
07:00		283								
08:00		208								
09:00		162								
10:00		142								
11:00		84								
Total		5808								
AM Peak	-	11:00	-	-	-	-	-	-	-	-
Vol.	-	475	-	-	-	-	-	-	-	-
PM Peak	-	13:00	-	-	-	-	-	-	-	-
Vol.	-	501	-	-	-	-	-	-	-	-
Grand Total		22336								
ADT		ADT 7,445	AADT 7,445							

Start Time	16-Dec-23 Sat	NB										
12:00 AM		70										
01:00		31										
02:00		20										
03:00		24										
04:00		20										
05:00		39										
06:00		76										
07:00		137										
08:00		220										
09:00		344										
10:00		439										
11:00		443										
12:00 PM		486										
01:00		473										
02:00		495										
03:00		476										
04:00		449										
05:00		434										
06:00		310										
07:00		278										
08:00		216										
09:00		154										
10:00		133										
11:00		85										
Total		5852										
AM Peak	-	11:00	-	-	-	-	-	-	-	-	-	-
Vol.	-	443	-	-	-	-	-	-	-	-	-	-
PM Peak	-	14:00	-	-	-	-	-	-	-	-	-	-
Vol.	-	495	-	-	-	-	-	-	-	-	-	-
Grand Total		21809										
ADT		ADT 7,270	AADT 7,270									

Start Time	14-Dec-23 Thu	NB	SB	Total						
12:00 AM		22	29	51						
01:00		13	43	56						
02:00		14	13	27						
03:00		16	18	34						
04:00		30	40	70						
05:00		92	130	222						
06:00		209	253	462						
07:00		306	507	813						
08:00		417	514	931						
09:00		379	350	729						
10:00		338	353	691						
11:00		376	392	768						
12:00 PM		418	395	813						
01:00		395	397	792						
02:00		457	381	838						
03:00		543	452	995						
04:00		581	476	1057						
05:00		545	355	900						
06:00		327	301	628						
07:00		212	190	402						
08:00		185	139	324						
09:00		117	110	227						
10:00		82	58	140						
11:00		61	47	108						
Total		6135	5943	12078						
Percent		50.8%	49.2%							
AM Peak	-	08:00	08:00	-	-	-	-	-	-	08:00
Vol.	-	417	514	-	-	-	-	-	-	931
PM Peak	-	16:00	16:00	-	-	-	-	-	-	16:00
Vol.	-	581	476	-	-	-	-	-	-	1057

Start Time	15-Dec-23 Fri	NB	SB	Total						
12:00 AM		27	43	70						
01:00		15	43	58						
02:00		17	13	30						
03:00		16	14	30						
04:00		28	31	59						
05:00		97	108	205						
06:00		165	256	421						
07:00		311	479	790						
08:00		409	482	891						
09:00		357	357	714						
10:00		427	350	777						
11:00		371	391	762						
12:00 PM		450	391	841						
01:00		418	382	800						
02:00		503	424	927						
03:00		561	492	1053						
04:00		526	493	1019						
05:00		500	420	920						
06:00		364	318	682						
07:00		218	201	419						
08:00		213	168	381						
09:00		143	129	272						
10:00		102	84	186						
11:00		60	47	107						
Total		6298	6116	12414						
Percent		50.7%	49.3%							
AM Peak	-	10:00	08:00	-	-	-	-	-	-	08:00
Vol.	-	427	482	-	-	-	-	-	-	891
PM Peak	-	15:00	16:00	-	-	-	-	-	-	15:00
Vol.	-	561	493	-	-	-	-	-	-	1053

Start Time	16-Dec-23 Sat	NB	SB	Total						
12:00 AM		50	76	126						
01:00		21	25	46						
02:00		18	17	35						
03:00		19	10	29						
04:00		20	23	43						
05:00		44	50	94						
06:00		56	44	100						
07:00		122	91	213						
08:00		179	182	361						
09:00		293	236	529						
10:00		354	327	681						
11:00		352	367	719						
12:00 PM		355	349	704						
01:00		395	341	736						
02:00		333	331	664						
03:00		321	284	605						
04:00		379	362	741						
05:00		297	296	593						
06:00		235	200	435						
07:00		192	170	362						
08:00		144	150	294						
09:00		109	107	216						
10:00		91	92	183						
11:00		69	56	125						
Total		4448	4186	8634						
Percent		51.5%	48.5%							
AM Peak	-	10:00	11:00	-	-	-	-	-	-	11:00
Vol.	-	354	367	-	-	-	-	-	-	719
PM Peak	-	13:00	16:00	-	-	-	-	-	-	16:00
Vol.	-	395	362	-	-	-	-	-	-	741
Grand Total		16881	16245							33126
Percent		51.0%	49.0%							
ADT		ADT 11,042		AADT 11,042						



Appendix D

Speed Data Collection

All Traffic Data Services, LLC
www.alltrafficdata.net

Site Code: 23
ST JOHNS RD N.O RAILROAD

NB

Start Time	15	20	25	30	35	40	45	50	55	60	65	70	75	999	Total	Pace Speed	Number in Pace
12/14/23	0	0	2	2	2	8	5	2	1	0	0	0	0	0	22	36-45	13
01:00	0	0	2	0	5	4	2	0	0	0	0	0	0	0	13	31-40	9
02:00	1	0	0	0	4	6	2	0	0	1	0	0	0	0	14	31-40	10
03:00	0	1	2	2	2	4	4	0	1	0	0	0	0	0	16	35-44	8
04:00	0	1	2	1	5	14	4	3	0	0	0	0	0	0	30	31-40	19
05:00	1	2	6	7	12	27	25	8	3	0	1	0	0	0	92	36-45	52
06:00	7	8	14	11	32	57	60	16	3	1	0	0	0	0	209	36-45	117
07:00	18	14	11	26	79	102	42	12	2	0	0	0	0	0	306	31-40	181
08:00	30	22	35	52	104	125	37	10	0	0	0	0	0	2	417	31-40	229
09:00	28	15	51	51	89	110	31	4	0	0	0	0	0	0	379	31-40	199
10:00	16	9	15	59	121	81	32	4	0	0	0	1	0	0	338	31-40	202
11:00	20	7	23	45	114	121	39	5	1	0	0	0	0	1	376	31-40	235
12 PM	21	10	26	57	120	112	59	11	1	0	0	0	0	1	418	31-40	232
13:00	19	7	17	53	116	125	44	12	1	0	1	0	0	0	395	31-40	241
14:00	35	16	21	42	109	149	66	15	3	0	0	0	0	1	457	31-40	258
15:00	28	9	30	41	119	198	94	21	1	1	0	0	0	1	543	31-40	317
16:00	32	8	40	57	99	223	89	25	3	1	0	0	0	4	581	31-40	322
17:00	21	5	29	44	122	197	103	17	4	3	0	0	0	0	545	31-40	319
18:00	3	7	21	24	61	122	72	11	4	0	0	0	0	2	327	36-45	194
19:00	6	1	11	20	54	76	36	6	2	0	0	0	0	0	212	31-40	130
20:00	3	2	9	11	28	74	42	11	4	1	0	0	0	0	185	36-45	116
21:00	2	2	4	8	29	36	31	3	1	1	0	0	0	0	117	36-45	67
22:00	0	0	4	3	12	39	19	3	1	0	1	0	0	0	82	36-45	58
23:00	0	1	6	6	14	20	12	2	0	0	0	0	0	0	61	31-40	34
Total	291	147	381	622	1452	2030	950	201	36	9	3	1	0	12	6135		
Percent	4.7%	2.4%	6.2%	10.1%	23.7%	33.1%	15.5%	3.3%	0.6%	0.1%	0.0%	0.0%	0.0%	0.2%			
AM Peak	08:00	08:00	09:00	10:00	10:00	08:00	06:00	06:00	05:00	02:00	05:00	10:00		08:00	08:00		
Vol.	30	22	51	59	121	125	60	16	3	1	1	1		2	417		
PM Peak	14:00	14:00	16:00	12:00	17:00	16:00	17:00	16:00	17:00	17:00	13:00			16:00	16:00		
Vol.	35	16	40	57	122	223	103	25	4	3	1			4	581		

All Traffic Data Services, LLC
www.alltrafficdata.net

Site Code: 23
ST JOHNS RD N.O RAILROAD

NB

Start Time	15	20	25	30	35	40	45	50	55	60	65	70	75	999	Total	Pace Speed	Number in Pace
12/15/23	0	1	2	2	2	9	10	1	0	0	0	0	0	0	27	36-45	19
01:00	0	0	2	0	5	4	3	1	0	0	0	0	0	0	15	31-40	9
02:00	0	0	0	2	5	4	6	0	0	0	0	0	0	0	17	34-43	10
03:00	1	1	2	1	6	2	3	0	0	0	0	0	0	0	16	31-40	8
04:00	1	0	1	2	5	13	5	1	0	0	0	0	0	0	28	31-40	18
05:00	1	5	6	7	15	31	19	11	1	0	0	0	0	1	97	36-45	50
06:00	6	5	5	9	32	54	33	18	2	1	0	0	0	0	165	34-43	87
07:00	10	11	18	33	48	97	67	22	4	0	0	0	0	1	311	36-45	164
08:00	20	11	45	47	73	117	79	13	4	0	0	0	0	0	409	36-45	196
09:00	18	5	22	33	72	120	65	19	2	1	0	0	0	0	357	31-40	192
10:00	20	8	21	33	92	151	81	17	4	0	0	0	0	0	427	31-40	243
11:00	20	8	17	36	70	128	79	11	2	0	0	0	0	0	371	36-45	207
12 PM	30	10	29	45	92	133	92	16	1	0	0	0	1	1	450	31-40	225
13:00	17	7	14	34	93	136	90	21	4	0	1	1	0	0	418	31-40	229
14:00	21	5	20	26	106	173	114	28	9	1	0	0	0	0	503	36-45	287
15:00	25	5	14	33	120	197	121	36	10	0	0	0	0	0	561	34-43	318
16:00	27	15	38	48	114	173	77	22	7	2	0	1	0	2	526	31-40	287
17:00	18	13	41	37	104	166	97	18	3	1	0	0	0	2	500	31-40	270
18:00	13	10	19	30	72	127	78	11	4	0	0	0	0	0	364	36-45	205
19:00	5	4	5	16	46	77	58	4	3	0	0	0	0	0	218	36-45	135
20:00	3	2	13	10	33	85	54	11	2	0	0	0	0	0	213	36-45	139
21:00	4	1	3	9	22	54	40	9	1	0	0	0	0	0	143	36-45	94
22:00	0	0	4	5	19	40	26	7	1	0	0	0	0	0	102	36-45	66
23:00	0	0	0	4	9	30	13	2	2	0	0	0	0	0	60	36-45	43
Total	260	127	341	502	1255	2121	1310	299	66	6	1	2	1	7	6298		
Percent	4.1%	2.0%	5.4%	8.0%	19.9%	33.7%	20.8%	4.7%	1.0%	0.1%	0.0%	0.0%	0.0%	0.1%			
AM Peak	08:00	07:00	08:00	08:00	10:00	10:00	10:00	07:00	07:00	06:00				05:00	10:00		
Vol.	20	11	45	47	92	151	81	22	4	1				1	427		
PM Peak	12:00	16:00	17:00	16:00	15:00	15:00	15:00	15:00	15:00	16:00	13:00	13:00	12:00	16:00	15:00		
Vol.	30	15	41	48	120	197	121	36	10	2	1	1	1	2	561		

Site Code: 23
ST JOHNS RD N.O RAILROAD

NB	Start Time	15	20	25	30	35	40	45	50	55	60	65	70	75	999	Total	Pace Speed	Number in Pace
12/16/23		1	0	2	3	10	19	11	4	0	0	0	0	0	0	50	36-45	30
01:00		1	1	2	1	5	7	3	1	0	0	0	0	0	0	21	31-40	12
02:00		0	0	2	1	0	10	2	2	1	0	0	0	0	0	18	35-44	12
03:00		0	0	0	2	3	5	6	2	1	0	0	0	0	0	19	36-45	11
04:00		0	4	3	1	4	4	4	0	0	0	0	0	0	0	20	36-45	8
05:00		0	1	1	3	9	18	9	2	0	1	0	0	0	0	44	31-40	27
06:00		0	2	0	8	12	11	15	6	1	1	0	0	0	0	56	36-45	26
07:00		1	3	5	10	19	38	36	9	1	0	0	0	0	0	122	36-45	74
08:00		2	7	24	24	25	53	30	9	2	2	1	0	0	0	179	36-45	83
09:00		6	10	29	18	48	96	58	22	6	0	0	0	0	0	293	36-45	154
10:00		7	1	16	24	57	131	86	27	4	0	1	0	0	0	354	36-45	217
11:00		6	1	6	22	65	129	102	14	3	2	0	1	0	1	352	36-45	231
12 PM		14	3	14	25	62	121	89	22	4	1	0	0	0	0	355	36-45	210
13:00		9	4	11	23	71	155	88	28	6	0	0	0	0	0	395	36-45	243
14:00		19	5	8	25	46	111	89	22	4	2	0	0	0	2	333	36-45	200
15:00		8	3	1	14	76	117	81	18	2	1	0	0	0	0	321	36-45	198
16:00		7	2	20	28	69	150	85	14	3	0	0	0	0	1	379	36-45	235
17:00		6	3	8	19	64	112	64	21	0	0	0	0	0	0	297	31-40	176
18:00		6	2	10	13	34	86	67	15	1	1	0	0	0	0	235	36-45	153
19:00		2	0	7	15	26	74	53	14	1	0	0	0	0	0	192	36-45	127
20:00		2	3	4	8	31	59	29	6	2	0	0	0	0	0	144	31-40	90
21:00		0	1	4	8	19	37	30	7	3	0	0	0	0	0	109	36-45	67
22:00		0	1	2	5	15	33	25	9	1	0	0	0	0	0	91	36-45	58
23:00		0	0	0	2	17	27	14	5	4	0	0	0	0	0	69	31-40	44
Total		97	57	179	302	787	1603	1076	279	50	11	2	1	0	4	4448		
Percent		2.2%	1.3%	4.0%	6.8%	17.7%	36.0%	24.2%	6.3%	1.1%	0.2%	0.0%	0.0%	0.0%	0.1%			
AM Peak	10:00	09:00	09:00	08:00	11:00	10:00	11:00	10:00	09:00	08:00	08:00	11:00			11:00	10:00		
Vol.	7	10	29	24	65	131	102	27	6	2	1	1			1	354		
PM Peak	14:00	14:00	16:00	16:00	15:00	13:00	12:00	13:00	13:00	14:00					14:00	13:00		
Vol.	19	5	20	28	76	155	89	28	6	2					2	395		
Total	648	331	901	1426	3494	5754	3336	779	152	26	6	4	1	23	16881			
Percent	3.8%	2.0%	5.3%	8.4%	20.7%	34.1%	19.8%	4.6%	0.9%	0.2%	0.0%	0.0%	0.0%	0.1%				

15th Percentile : 27 MPH
 50th Percentile : 36 MPH
 85th Percentile : 42 MPH
 95th Percentile : 45 MPH

Stats
 10 MPH Pace Speed : 31-40 MPH
 Number in Pace : 9248
 Percent in Pace : 54.8%
 Number of Vehicles > 40 MPH : 4327
 Percent of Vehicles > 40 MPH : 25.6%
 Mean Speed(Average) : 35 MPH

All Traffic Data Services, LLC
www.alltrafficdata.net

Site Code: 23
ST JOHNS RD N.O RAILROAD

SB

Start Time	1 15	16 20	21 25	26 30	31 35	36 40	41 45	46 50	51 55	56 60	61 65	66 70	71 75	76 999	Total	Pace Speed	Number in Pace
12/14/23	0	1	5	4	3	11	5	0	0	0	0	0	0	0	29	35-44	16
01:00	0	1	20	12	0	5	4	0	1	0	0	0	0	0	43	21-30	32
02:00	0	0	0	3	2	3	2	3	0	0	0	0	0	0	13	38-47	5
03:00	0	0	2	3	2	6	3	1	1	0	0	0	0	0	18	34-43	9
04:00	0	0	3	2	8	11	14	1	0	0	1	0	0	0	40	36-45	25
05:00	4	6	9	12	7	30	38	21	3	0	0	0	0	0	130	36-45	68
06:00	8	9	14	18	21	78	74	25	5	1	0	0	0	0	253	36-45	152
07:00	13	9	34	47	76	170	129	24	2	2	0	0	1	0	507	36-45	299
08:00	27	12	31	48	65	166	128	32	4	0	0	1	0	0	514	36-45	294
09:00	19	8	14	31	56	127	76	17	2	0	0	0	0	0	350	36-45	203
10:00	14	4	19	30	76	122	69	17	2	0	0	0	0	0	353	31-40	198
11:00	20	8	13	35	77	157	65	17	0	0	0	0	0	0	392	31-40	234
12 PM	16	2	28	42	74	123	87	20	2	0	0	0	0	1	395	36-45	210
13:00	18	9	20	42	48	136	93	27	3	0	0	0	0	1	397	36-45	229
14:00	23	5	12	34	58	123	90	32	3	0	0	0	0	1	381	36-45	213
15:00	25	5	14	29	54	147	134	32	10	0	1	0	0	1	452	36-45	281
16:00	14	10	13	33	83	173	126	21	1	0	0	0	0	2	476	36-45	299
17:00	10	3	6	24	46	141	108	13	4	0	0	0	0	0	355	36-45	249
18:00	3	3	9	18	46	109	86	22	4	0	0	0	0	1	301	36-45	195
19:00	1	0	2	14	31	67	64	11	0	0	0	0	0	0	190	36-45	131
20:00	0	1	7	13	16	50	41	6	4	1	0	0	0	0	139	36-45	91
21:00	2	1	3	9	12	37	35	10	1	0	0	0	0	0	110	36-45	72
22:00	0	2	3	4	7	21	14	5	1	1	0	0	0	0	58	36-45	35
23:00	0	0	1	4	10	12	14	5	1	0	0	0	0	0	47	36-45	26
Total	217	99	282	511	878	2025	1499	362	54	5	2	1	1	7	5943		
Percent	3.7%	1.7%	4.7%	8.6%	14.8%	34.1%	25.2%	6.1%	0.9%	0.1%	0.0%	0.0%	0.0%	0.1%			
AM Peak	08:00	08:00	07:00	08:00	11:00	07:00	07:00	08:00	06:00	07:00	04:00	08:00	07:00				08:00
Vol.	27	12	34	48	77	170	129	32	5	2	1	1	1		514		
PM Peak	15:00	16:00	12:00	12:00	16:00	16:00	15:00	14:00	15:00	20:00	15:00			16:00	16:00		
Vol.	25	10	28	42	83	173	134	32	10	1	1			2	476		

Site Code: 23
ST JOHNS RD N.O RAILROAD

SB

Start Time	15	20	25	30	35	40	45	50	55	60	65	70	75	999	Total	Pace Speed	Number in Pace
12/15/23	0	2	3	6	6	11	11	4	0	0	0	0	0	0	43	36-45	22
01:00	0	3	19	12	2	4	1	2	0	0	0	0	0	0	43	21-30	31
02:00	0	1	2	1	4	3	2	0	0	0	0	0	0	0	13	30-39	7
03:00	1	1	0	1	3	2	6	0	0	0	0	0	0	0	14	36-45	8
04:00	0	2	2	1	6	10	7	3	0	0	0	0	0	0	31	34-43	17
05:00	0	5	9	11	8	33	26	15	1	0	0	0	0	0	108	36-45	59
06:00	9	8	11	20	30	82	69	24	3	0	0	0	0	0	256	36-45	151
07:00	16	4	30	44	55	154	138	30	4	2	0	1	0	1	479	36-45	292
08:00	20	11	35	44	62	147	114	45	3	0	0	1	0	0	482	36-45	261
09:00	9	4	11	30	38	128	97	36	3	1	0	0	0	0	357	36-45	225
10:00	6	6	23	41	41	106	92	27	6	1	1	0	0	0	350	36-45	198
11:00	13	2	16	25	49	128	119	31	6	1	0	0	0	1	391	36-45	247
12 PM	15	8	17	37	64	124	97	24	4	0	0	1	0	0	391	36-45	221
13:00	17	10	12	26	43	119	116	36	2	0	1	0	0	0	382	36-45	235
14:00	28	7	14	37	65	124	110	33	5	0	0	0	0	1	424	36-45	234
15:00	39	7	12	34	46	152	145	50	7	0	0	0	0	0	492	36-45	297
16:00	30	7	12	25	70	167	131	42	6	0	1	0	0	2	493	36-45	298
17:00	17	3	11	26	54	167	108	29	1	1	0	0	0	3	420	36-45	275
18:00	6	3	4	25	36	120	95	25	4	0	0	0	0	0	318	36-45	215
19:00	3	0	1	21	26	78	41	22	5	3	1	0	0	0	201	36-45	119
20:00	2	2	2	3	29	64	48	14	2	1	0	0	0	1	168	36-45	112
21:00	0	0	4	9	23	39	40	10	4	0	0	0	0	0	129	36-45	79
22:00	0	1	1	8	8	30	28	4	3	1	0	0	0	0	84	36-45	58
23:00	0	2	4	5	3	13	15	4	1	0	0	0	0	0	47	36-45	28
Total	231	99	255	492	771	2005	1656	510	70	11	4	3	0	9	6116		
Percent	3.8%	1.6%	4.2%	8.0%	12.6%	32.8%	27.1%	8.3%	1.1%	0.2%	0.1%	0.0%	0.0%	0.1%			
AM Peak	08:00	08:00	08:00	07:00	08:00	07:00	07:00	08:00	10:00	07:00	10:00	07:00		07:00	08:00		
Vol.	20	11	35	44	62	154	138	45	6	2	1	1		1	482		
PM Peak	15:00	13:00	12:00	12:00	16:00	16:00	15:00	15:00	15:00	19:00	13:00	12:00		17:00	16:00		
Vol.	39	10	17	37	70	167	145	50	7	3	1	1		3	493		

Site Code: 23
ST JOHNS RD N.O RAILROAD

SB

Start Time	1 15	16 20	21 25	26 30	31 35	36 40	41 45	46 50	51 55	56 60	61 65	66 70	71 75	76 999	Total	Pace Speed	Number in Pace
12/16/23	0	2	12	11	11	15	18	4	2	1	0	0	0	0	76	36-45	33
01:00	0	0	4	1	1	10	6	3	0	0	0	0	0	0	25	36-45	16
02:00	0	0	0	1	2	6	3	2	2	1	0	0	0	0	17	34-43	9
03:00	0	1	1	0	2	2	2	1	1	0	0	0	0	0	10	36-45	4
04:00	0	2	2	0	2	9	7	1	0	0	0	0	0	0	23	36-45	16
05:00	0	1	3	3	5	15	12	7	3	1	0	0	0	0	50	36-45	27
06:00	0	2	1	4	3	13	16	3	2	0	0	0	0	0	44	36-45	29
07:00	0	3	3	11	15	24	23	10	2	0	0	0	0	0	91	36-45	47
08:00	2	0	10	24	30	45	51	16	3	1	0	0	0	0	182	36-45	96
09:00	5	2	9	21	30	61	75	28	4	1	0	0	0	0	236	36-45	136
10:00	4	2	6	23	37	90	118	33	12	2	0	0	0	0	327	36-45	208
11:00	11	2	2	28	34	103	136	39	11	1	0	0	0	0	367	36-45	239
12 PM	14	2	3	25	44	115	102	38	5	0	0	0	0	1	349	36-45	217
13:00	48	0	5	17	19	89	112	46	4	1	0	0	0	0	341	36-45	201
14:00	55	1	6	9	35	88	97	35	4	1	0	0	0	0	331	36-45	185
15:00	21	5	3	18	35	71	86	38	6	0	1	0	0	0	284	36-45	157
16:00	15	6	13	21	55	98	102	40	12	0	0	0	0	0	362	36-45	200
17:00	5	6	8	16	33	117	86	22	3	0	0	0	0	0	296	36-45	203
18:00	1	0	6	13	15	68	65	28	3	1	0	0	0	0	200	36-45	133
19:00	1	1	4	17	16	47	64	16	4	0	0	0	0	0	170	36-45	111
20:00	2	1	1	8	14	50	58	10	6	0	0	0	0	0	150	36-45	108
21:00	0	0	2	8	9	40	33	12	3	0	0	0	0	0	107	36-45	73
22:00	0	0	1	6	14	27	34	10	0	0	0	0	0	0	92	36-45	61
23:00	0	1	0	1	5	23	18	8	0	0	0	0	0	0	56	36-45	41
Total	184	40	105	286	466	1226	1324	450	92	11	1	0	0	1	4186		
Percent	4.4%	1.0%	2.5%	6.8%	11.1%	29.3%	31.6%	10.8%	2.2%	0.3%	0.0%	0.0%	0.0%	0.0%			
AM Peak	11:00	07:00	00:00	11:00	10:00	11:00	11:00	11:00	10:00	10:00					11:00		
Vol.	11	3	12	28	37	103	136	39	12	2					367		
PM Peak	14:00	16:00	16:00	12:00	16:00	17:00	13:00	13:00	16:00	13:00	15:00			12:00	16:00		
Vol.	55	6	13	25	55	117	112	46	12	1	1			1	362		
Total	632	238	642	1289	2115	5256	4479	1322	216	27	7	4	1	17	16245		
Percent	3.9%	1.5%	4.0%	7.9%	13.0%	32.4%	27.6%	8.1%	1.3%	0.2%	0.0%	0.0%	0.0%	0.1%			

15th Percentile : 28 MPH
50th Percentile : 38 MPH
85th Percentile : 44 MPH
95th Percentile : 47 MPH

Stats
10 MPH Pace Speed : 36-45 MPH
Number in Pace : 9735
Percent in Pace : 59.9%
Number of Vehicles > 40 MPH : 6073
Percent of Vehicles > 40 MPH : 37.4%
Mean Speed(Average) : 37 MPH

All Traffic Data Services, LLC
www.alltrafficdata.net

Site Code: 15
ST JOHNS BLVD S.O 30TH ST

NB

Start Time	15	20	25	30	35	40	45	50	55	60	65	70	75	999	Total	Pace Speed	Number in Pace
12/14/23	0	0	8	10	3	7	0	0	0	0	0	0	0	0	28	21-30	18
01:00	0	1	2	5	3	0	1	0	0	0	0	0	0	0	12	24-33	8
02:00	0	0	1	6	0	4	0	0	0	0	0	0	0	0	11	21-30	7
03:00	1	0	1	0	2	2	1	0	0	0	0	0	0	0	7	31-40	4
04:00	0	0	1	4	4	1	0	0	0	0	0	0	0	0	10	26-35	8
05:00	2	2	5	18	14	6	0	1	0	0	0	0	0	0	48	26-35	32
06:00	9	0	4	25	33	9	1	0	0	0	0	0	0	0	81	26-35	58
07:00	8	7	14	40	43	12	3	0	0	0	0	0	0	0	127	26-35	83
08:00	8	6	22	70	59	15	1	0	0	0	0	0	0	0	181	26-35	129
09:00	6	9	24	69	51	13	2	0	0	0	0	0	0	0	174	26-35	120
10:00	6	4	23	62	70	11	1	0	0	0	0	0	0	1	178	26-35	132
11:00	13	11	23	96	88	19	2	0	0	0	0	0	0	0	252	26-35	184
12 PM	13	11	30	103	90	13	1	0	0	0	0	0	0	1	262	26-35	193
13:00	7	8	21	74	84	17	2	2	0	0	0	0	0	0	215	26-35	158
14:00	15	12	28	81	119	21	3	0	1	0	1	0	1	0	282	26-35	200
15:00	13	14	39	120	137	27	0	1	0	0	0	0	1	0	352	26-35	257
16:00	14	11	45	168	118	22	1	0	0	0	0	0	0	0	379	26-35	286
17:00	16	13	35	151	95	16	0	0	0	0	0	0	0	0	326	26-35	246
18:00	12	8	26	89	62	4	1	0	1	0	0	0	0	0	203	26-35	151
19:00	3	5	21	65	37	5	1	0	0	0	0	0	0	0	137	26-35	102
20:00	11	7	25	48	32	9	5	0	0	0	0	0	0	0	137	26-35	80
21:00	7	5	13	38	37	4	0	0	0	0	0	0	0	0	104	26-35	75
22:00	7	2	6	36	27	8	2	0	0	0	0	0	0	0	88	26-35	63
23:00	2	0	7	8	13	5	0	0	0	0	0	0	0	0	35	26-35	21
Total	173	136	424	1386	1221	250	28	4	2	0	1	0	2	2	3629		
Percent	4.8%	3.7%	11.7%	38.2%	33.6%	6.9%	0.8%	0.1%	0.1%	0.0%	0.0%	0.0%	0.1%	0.1%			
AM Peak	11:00	11:00	09:00	11:00	11:00	11:00	07:00	05:00							10:00	11:00	
Vol.	13	11	24	96	88	19	3	1							1	252	
PM Peak	17:00	15:00	16:00	16:00	15:00	15:00	20:00	13:00	14:00		14:00		14:00	12:00	16:00		
Vol.	16	14	45	168	137	27	5	2	1		1		1	1	379		

All Traffic Data Services, LLC
www.alltrafficdata.net

Site Code: 15
ST JOHNS BLVD S.O 30TH ST

NB

Start Time	15	20	25	30	35	40	45	50	55	60	65	70	75	999	Total	Pace Speed	Number in Pace
12/15/23	0	1	2	8	5	3	0	0	0	0	0	0	0	0	19	26-35	13
01:00	0	0	5	5	2	2	1	0	0	0	0	0	0	0	15	21-30	10
02:00	0	1	1	6	3	1	0	0	0	0	0	0	0	0	12	25-34	9
03:00	1	0	2	1	4	1	0	1	0	0	0	0	0	0	10	28-37	5
04:00	0	0	3	3	9	0	0	0	0	0	0	0	0	0	15	26-35	12
05:00	2	1	0	19	15	6	1	0	0	1	0	0	0	0	45	26-35	34
06:00	2	2	3	31	25	6	1	0	0	0	0	0	0	0	70	26-35	56
07:00	11	5	9	48	40	10	0	0	0	0	0	0	0	0	123	26-35	88
08:00	16	7	20	68	67	19	0	0	0	0	0	0	0	0	197	26-35	135
09:00	11	9	18	63	83	22	0	0	0	0	0	0	0	0	206	26-35	146
10:00	7	7	14	54	75	13	2	1	0	0	0	0	0	1	174	26-35	129
11:00	8	3	8	77	85	22	5	0	1	0	1	0	0	0	210	26-35	162
12 PM	9	9	12	87	76	28	5	0	0	0	0	0	0	0	226	26-35	163
13:00	7	6	15	85	100	28	4	1	0	0	0	0	0	0	246	26-35	185
14:00	9	12	19	91	122	32	5	0	0	0	0	1	0	0	291	26-35	213
15:00	35	21	38	83	118	25	1	3	0	0	0	0	0	1	325	26-35	201
16:00	11	15	32	129	125	25	0	0	0	1	0	0	0	2	340	26-35	254
17:00	17	18	54	111	70	9	1	0	0	0	0	0	0	0	280	26-35	181
18:00	15	10	25	89	64	9	2	0	0	0	0	0	0	0	214	26-35	153
19:00	5	5	17	54	49	11	0	0	0	0	0	0	0	0	141	26-35	103
20:00	8	2	17	62	44	9	2	0	0	0	0	0	0	1	145	26-35	106
21:00	5	7	13	31	42	2	1	0	0	0	0	0	0	0	101	26-35	73
22:00	3	1	13	18	25	11	3	0	0	0	0	0	0	0	74	26-35	43
23:00	3	0	9	20	16	7	1	0	0	0	0	0	0	0	56	26-35	36
Total	185	142	349	1243	1264	301	35	6	1	2	1	1	0	5	3535		
Percent	5.2%	4.0%	9.9%	35.2%	35.8%	8.5%	1.0%	0.2%	0.0%	0.1%	0.0%	0.0%	0.0%	0.1%			
AM Peak	08:00	09:00	08:00	11:00	11:00	09:00	11:00	03:00	11:00	05:00	11:00				10:00	11:00	
Vol.	16	9	20	77	85	22	5	1	1	1	1			1	210		
PM Peak	15:00	15:00	17:00	16:00	16:00	14:00	12:00	15:00		16:00		14:00		16:00	16:00		
Vol.	35	21	54	129	125	32	5	3		1		1		2	340		

Site Code: 15
ST JOHNS BLVD S.O 30TH ST

NB

Start Time	15	20	25	30	35	40	45	50	55	60	65	70	75	999	Total	Pace Speed	Number in Pace
12/16/23	0	0	4	9	17	2	2	0	0	0	0	0	0	0	34	26-35	26
01:00	0	2	2	4	10	0	0	0	0	0	0	0	0	0	18	26-35	14
02:00	0	0	1	12	9	0	0	0	0	0	0	0	0	0	22	26-35	21
03:00	1	0	2	10	3	1	0	0	0	0	0	0	0	0	17	24-33	13
04:00	0	0	2	2	5	2	0	0	0	0	0	0	0	0	11	31-40	7
05:00	1	0	3	5	5	4	1	0	0	0	0	0	0	0	19	25-34	10
06:00	3	0	4	10	11	5	1	1	0	0	0	0	0	0	35	26-35	21
07:00	3	2	4	17	16	7	0	0	0	0	0	0	0	0	49	26-35	33
08:00	3	1	4	28	32	8	1	0	0	0	0	0	0	0	77	26-35	60
09:00	9	4	14	33	60	27	3	0	0	0	0	0	0	0	150	26-35	93
10:00	6	3	10	45	74	21	1	0	0	0	0	0	0	0	160	26-35	119
11:00	12	8	12	54	53	13	3	1	0	0	0	0	0	2	158	26-35	107
12 PM	10	8	14	69	68	16	3	1	0	0	0	0	0	0	189	26-35	137
13:00	14	7	11	46	99	22	5	0	1	0	0	0	0	0	205	26-35	145
14:00	4	12	14	58	87	21	3	0	0	0	0	1	0	0	200	26-35	145
15:00	9	10	15	71	69	19	6	1	0	0	0	0	0	0	200	26-35	140
16:00	6	11	37	89	45	5	0	0	0	0	0	0	0	0	193	26-35	134
17:00	13	11	24	89	39	13	2	0	0	0	0	0	0	0	191	26-35	128
18:00	8	10	18	51	24	10	2	0	0	0	0	0	0	0	123	26-35	75
19:00	5	4	12	55	34	11	2	0	0	0	0	0	0	0	123	26-35	89
20:00	1	4	17	37	33	9	2	0	1	0	0	0	0	0	104	26-35	70
21:00	5	1	16	35	25	5	1	0	0	0	0	0	0	0	88	26-35	60
22:00	2	3	7	24	19	3	1	0	0	0	0	0	0	0	59	26-35	43
23:00	1	1	3	23	25	8	1	1	0	0	0	0	0	0	63	26-35	48
Total	116	102	250	876	862	232	40	5	2	0	0	1	0	2	2488		
Percent	4.7%	4.1%	10.0%	35.2%	34.6%	9.3%	1.6%	0.2%	0.1%	0.0%	0.0%	0.0%	0.0%	0.1%			
AM Peak	11:00	11:00	09:00	11:00	10:00	09:00	09:00	06:00						11:00	10:00		
Vol.	12	8	14	54	74	27	3	1						2	160		
PM Peak	13:00	14:00	16:00	16:00	13:00	13:00	15:00	12:00	13:00			14:00			13:00		
Vol.	14	12	37	89	99	22	6	1	1			1			205		
Total	474	380	1023	3505	3347	783	103	15	5	2	2	2	2	9	9652		
Percent	4.9%	3.9%	10.6%	36.3%	34.7%	8.1%	1.1%	0.2%	0.1%	0.0%	0.0%	0.0%	0.0%	0.1%			

15th Percentile : 22 MPH
 50th Percentile : 29 MPH
 85th Percentile : 34 MPH
 95th Percentile : 37 MPH

Stats
 10 MPH Pace Speed : 26-35 MPH
 Number in Pace : 6852
 Percent in Pace : 71.0%
 Number of Vehicles > 30 MPH : 4270
 Percent of Vehicles > 30 MPH : 44.2%
 Mean Speed(Average) : 29 MPH

All Traffic Data Services, LLC
www.alltrafficdata.net

Site Code: 15
ST JOHNS BLVD S.O 30TH ST

SB

Start Time	15	20	25	30	35	40	45	50	55	60	65	70	75	999	Total	Pace Speed	Number in Pace
12/14/23	0	2	2	10	6	3	1	0	0	0	0	0	0	0	24	26-35	16
01:00	0	1	0	3	5	1	0	0	0	0	0	0	0	0	10	26-35	8
02:00	0	1	2	3	2	2	2	0	0	0	0	0	0	0	12	26-35	5
03:00	0	0	0	4	5	0	2	0	0	0	0	0	0	0	11	26-35	9
04:00	1	1	2	5	3	6	1	0	0	0	0	0	0	0	19	29-38	9
05:00	4	4	3	13	21	19	3	3	0	0	0	0	0	0	70	31-40	40
06:00	12	7	9	99	131	33	7	1	1	0	0	0	0	0	300	26-35	230
07:00	9	4	36	257	234	35	4	0	0	0	0	0	0	0	579	26-35	491
08:00	8	11	48	191	171	14	2	0	0	0	0	1	0	0	446	26-35	362
09:00	6	11	14	63	123	31	3	1	0	0	0	0	0	1	253	26-35	186
10:00	12	6	22	86	102	22	0	0	0	0	0	0	0	0	250	26-35	188
11:00	6	6	13	83	93	21	4	1	0	0	0	0	0	0	227	26-35	176
12 PM	12	7	27	85	122	25	5	0	0	0	0	0	0	0	283	26-35	207
13:00	12	11	10	61	83	38	4	0	0	0	0	0	0	1	220	26-35	144
14:00	15	5	24	90	99	14	2	0	0	0	0	0	0	0	249	26-35	189
15:00	9	13	22	90	79	32	1	0	0	0	0	0	0	0	246	26-35	169
16:00	15	10	14	86	68	16	2	1	0	0	0	0	0	0	212	26-35	154
17:00	16	5	14	82	90	11	6	0	0	0	0	0	0	0	224	26-35	172
18:00	14	7	8	69	66	15	3	0	0	0	0	0	0	0	182	26-35	135
19:00	8	2	5	25	47	9	1	0	0	0	0	0	0	0	97	26-35	72
20:00	5	4	5	28	42	10	3	0	0	0	0	0	0	0	97	26-35	70
21:00	6	6	3	27	24	8	0	0	0	0	0	0	0	0	74	26-35	51
22:00	2	2	0	12	22	5	0	0	0	0	0	0	0	0	43	26-35	34
23:00	0	0	1	14	9	5	1	0	0	0	0	0	0	0	30	26-35	23
Total	172	126	284	1486	1647	375	57	7	1	0	0	1	0	2	4158		
Percent	4.1%	3.0%	6.8%	35.7%	39.6%	9.0%	1.4%	0.2%	0.0%	0.0%	0.0%	0.0%	0.0%	0.0%			
AM Peak	06:00	08:00	08:00	07:00	07:00	07:00	06:00	05:00	06:00			08:00		09:00	07:00		
Vol.	12	11	48	257	234	35	7	3	1			1		1	579		
PM Peak	17:00	15:00	12:00	14:00	12:00	13:00	17:00	16:00						13:00	12:00		
Vol.	16	13	27	90	122	38	6	1						1	283		

All Traffic Data Services, LLC
www.alltrafficdata.net

Site Code: 15
ST JOHNS BLVD S.O 30TH ST

SB

Start Time	15	20	25	30	35	40	45	50	55	60	65	70	75	999	Total	Pace Speed	Number in Pace
12/15/23	1	0	3	6	10	5	0	0	0	0	0	0	0	0	25	26-35	16
01:00	0	0	1	3	8	1	2	0	0	0	0	0	0	0	15	26-35	11
02:00	0	0	0	2	5	0	0	1	0	0	0	0	0	0	8	26-35	7
03:00	0	1	0	3	6	1	1	0	0	0	0	0	0	0	12	26-35	9
04:00	0	1	1	8	8	2	0	0	0	0	0	0	0	0	20	26-35	16
05:00	3	3	1	11	21	11	5	1	0	0	0	0	0	0	56	26-35	32
06:00	5	4	5	46	118	36	4	0	1	0	0	0	0	0	219	26-35	164
07:00	12	3	19	122	159	37	4	0	0	0	0	0	0	0	356	26-35	281
08:00	10	9	35	137	143	34	3	0	0	0	0	0	0	0	371	26-35	280
09:00	9	8	10	64	144	38	4	0	0	0	0	0	0	0	277	26-35	208
10:00	9	1	6	34	87	30	6	1	0	0	0	0	0	0	174	26-35	121
11:00	8	10	7	50	87	33	3	0	0	0	0	0	0	0	198	26-35	137
12 PM	11	7	10	55	115	38	5	0	0	0	0	0	0	0	241	26-35	170
13:00	12	5	7	61	98	43	10	0	0	0	0	0	0	2	238	26-35	159
14:00	7	8	9	69	101	37	3	0	0	0	0	0	0	0	234	26-35	170
15:00	16	6	20	76	99	30	0	0	0	0	0	0	0	0	247	26-35	175
16:00	13	9	17	88	85	23	0	0	0	0	0	0	0	0	235	26-35	173
17:00	14	7	19	70	75	12	3	0	1	0	0	0	0	0	201	26-35	145
18:00	15	5	17	70	81	12	2	0	0	0	0	0	0	0	202	26-35	151
19:00	11	6	13	58	47	9	2	0	0	0	0	0	0	0	146	26-35	105
20:00	4	7	6	46	43	11	0	0	0	0	0	0	0	0	117	26-35	89
21:00	5	1	10	21	31	6	1	0	0	0	0	0	0	0	75	26-35	52
22:00	5	0	5	12	26	7	1	0	0	0	0	0	0	0	56	26-35	38
23:00	2	2	1	21	29	1	3	0	0	0	0	0	0	0	59	26-35	50
Total	172	103	222	1133	1626	457	62	3	2	0	0	0	0	2	3782		
Percent	4.5%	2.7%	5.9%	30.0%	43.0%	12.1%	1.6%	0.1%	0.1%	0.0%	0.0%	0.0%	0.0%	0.1%			
AM Peak	07:00	11:00	08:00	08:00	07:00	09:00	10:00	02:00	06:00						08:00		
Vol.	12	10	35	137	159	38	6	1	1						371		
PM Peak	15:00	16:00	15:00	16:00	12:00	13:00	13:00		17:00					13:00	15:00		
Vol.	16	9	20	88	115	43	10		1					2	247		

Site Code: 15
ST JOHNS BLVD S.O 30TH ST

SB

Start Time	15	20	25	30	35	40	45	50	55	60	65	70	75	999	Total	Pace Speed	Number in Pace
12/16/23	0	3	1	13	11	5	1	0	0	0	0	0	0	0	34	26-35	24
01:00	2	0	0	10	11	2	0	0	1	0	0	0	0	0	26	26-35	21
02:00	0	0	0	6	13	2	0	0	0	0	0	0	0	0	21	26-35	19
03:00	1	0	1	4	3	4	1	0	0	0	0	0	0	0	14	25-34	7
04:00	0	0	2	4	5	3	1	0	0	0	0	0	0	0	15	26-35	9
05:00	0	1	1	6	10	5	2	1	0	0	0	0	0	0	26	26-35	16
06:00	3	1	0	6	13	12	5	0	0	0	0	0	0	0	40	31-40	25
07:00	0	3	5	14	30	11	5	1	0	0	0	0	0	0	69	26-35	44
08:00	2	1	6	21	27	23	3	1	1	0	0	0	0	0	85	31-40	50
09:00	6	7	10	31	67	24	5	2	0	0	0	0	0	0	152	26-35	98
10:00	7	5	8	41	62	26	5	1	0	0	0	0	0	0	155	26-35	103
11:00	9	7	7	36	76	33	6	0	0	0	0	0	0	0	174	26-35	112
12 PM	6	7	9	40	66	28	8	1	0	0	0	0	0	0	165	26-35	106
13:00	12	8	16	54	81	27	5	1	0	0	0	0	0	0	204	26-35	135
14:00	6	6	11	66	76	31	1	0	0	0	0	0	0	0	197	26-35	142
15:00	8	3	12	46	74	19	5	0	0	0	0	0	0	0	167	26-35	120
16:00	12	6	17	62	84	19	5	0	0	0	1	0	0	0	206	26-35	146
17:00	16	5	10	79	79	22	1	0	0	0	0	0	0	0	212	26-35	158
18:00	4	6	11	42	42	12	3	0	0	0	0	0	0	0	120	26-35	84
19:00	8	4	7	33	48	11	1	0	0	0	0	0	0	0	112	26-35	81
20:00	3	4	7	23	33	16	4	1	0	0	0	0	0	0	91	26-35	56
21:00	2	5	2	23	24	15	2	0	0	0	0	0	0	0	73	26-35	47
22:00	8	1	8	26	22	7	1	0	0	0	0	0	0	0	73	26-35	48
23:00	2	4	1	10	24	9	0	0	0	0	0	0	0	0	50	26-35	34
Total	117	87	152	696	981	366	70	9	2	0	1	0	0	0	2481		
Percent	4.7%	3.5%	6.1%	28.1%	39.5%	14.8%	2.8%	0.4%	0.1%	0.0%	0.0%	0.0%	0.0%	0.0%			
AM Peak	11:00	09:00	09:00	10:00	11:00	11:00	11:00	09:00	01:00								11:00
Vol.	9	7	10	41	76	33	6	2	1								174
PM Peak	17:00	13:00	16:00	17:00	16:00	14:00	12:00	12:00			16:00						17:00
Vol.	16	8	17	79	84	31	8	1			1						212
Total	461	316	658	3315	4254	1198	189	19	5	0	1	1	0	4	10421		
Percent	4.4%	3.0%	6.3%	31.8%	40.8%	11.5%	1.8%	0.2%	0.0%	0.0%	0.0%	0.0%	0.0%	0.0%			

15th Percentile : 25 MPH
 50th Percentile : 30 MPH
 85th Percentile : 34 MPH
 95th Percentile : 38 MPH

Stats
 10 MPH Pace Speed : 26-35 MPH
 Number in Pace : 7569
 Percent in Pace : 72.6%
 Number of Vehicles > 30 MPH : 5671
 Percent of Vehicles > 30 MPH : 54.4%
 Mean Speed(Average) : 30 MPH

Site Code: 16
ST JOHNS BLVD N.O N.O 33RD ST

NB

Start Time	15	20	25	30	35	40	45	50	55	60	65	70	75	999	Total	Pace Speed	Number in Pace
12/14/23	8	8	0	1	4	0	0	0	1	0	0	2	0	4	28	11-20	11
01:00	1	1	3	2	0	1	0	1	0	0	0	0	0	6	15	21-30	5
02:00	0	0	4	4	0	2	1	0	0	1	3	0	0	5	20	21-30	8
03:00	2	5	4	6	1	0	1	0	0	1	0	0	0	3	23	19-28	10
04:00	7	2	11	10	5	2	0	0	1	0	1	1	0	8	48	21-30	21
05:00	19	5	6	9	10	7	6	6	1	4	2	0	0	3	78	26-35	19
06:00	105	15	17	21	10	4	5	2	1	0	0	0	1	2	183	6-15	70
07:00	168	15	5	1	2	1	0	1	1	0	0	0	0	0	194	6-15	112
08:00	174	3	3	1	0	0	0	0	0	0	0	0	0	4	185	1-10	116
09:00	130	4	0	3	0	0	0	0	0	0	0	0	1	0	138	1-10	87
10:00	122	1	0	1	2	2	0	0	0	0	0	0	0	1	129	6-15	81
11:00	77	93	43	82	44	10	1	0	0	0	0	0	0	1	351	16-25	136
12 PM	54	135	35	139	73	4	0	0	0	0	0	1	1	0	442	26-35	212
13:00	58	165	34	108	95	14	5	1	0	0	0	0	0	0	480	26-35	203
14:00	76	156	44	119	103	10	0	0	1	0	0	0	0	0	509	26-35	222
15:00	94	152	50	148	107	19	5	0	0	0	0	0	1	0	576	26-35	255
16:00	137	145	64	113	43	4	2	0	1	1	0	0	0	0	510	16-25	209
17:00	83	137	38	104	51	4	1	1	0	0	0	0	0	0	419	16-25	175
18:00	52	140	29	86	72	10	1	0	0	0	0	0	0	2	392	16-25	169
19:00	17	95	15	91	68	6	1	0	0	0	0	0	0	0	293	26-35	159
20:00	24	110	32	76	44	6	1	0	0	0	0	0	0	0	293	16-25	142
21:00	21	72	26	72	39	5	0	0	0	1	0	0	0	0	236	26-35	111
22:00	5	52	11	41	43	4	0	0	0	0	0	0	0	0	156	26-35	84
23:00	5	31	9	16	17	5	0	0	0	0	0	0	0	0	83	16-25	40
Total	1439	1542	483	1254	833	120	30	12	7	8	6	4	4	39	5781		
Percent	24.9%	26.7%	8.4%	21.7%	14.4%	2.1%	0.5%	0.2%	0.1%	0.1%	0.1%	0.1%	0.1%	0.7%			
AM Peak	08:00	11:00	11:00	11:00	11:00	11:00	05:00	05:00	00:00	05:00	02:00	00:00	06:00	04:00	11:00		
Vol.	174	93	43	82	44	10	6	6	1	4	3	2	1	8	351		
PM Peak	16:00	13:00	16:00	15:00	15:00	15:00	13:00	13:00	14:00	16:00		12:00	12:00	18:00	15:00		
Vol.	137	165	64	148	107	19	5	1	1	1		1	1	2	576		

All Traffic Data Services, LLC
www.alltrafficdata.net

Site Code: 16
ST JOHNS BLVD N.O N.O 33RD ST

NB

Start Time	15	20	25	30	35	40	45	50	55	60	65	70	75	999	Total	Pace Speed	Number in Pace
12/15/23	4	23	4	11	10	1	1	0	0	0	0	0	0	0	54	16-25	27
01:00	1	10	7	13	4	1	0	0	0	0	0	0	0	0	36	21-30	20
02:00	3	12	2	8	3	1	0	0	0	0	0	0	0	0	29	14-23	14
03:00	3	6	4	5	3	3	2	0	0	0	0	0	0	0	26	16-25	10
04:00	1	14	4	15	11	2	1	0	0	0	0	0	0	0	48	26-35	26
05:00	12	52	11	32	36	4	1	0	1	0	0	0	0	0	149	26-35	68
06:00	29	84	17	53	33	5	0	0	0	0	0	0	0	0	221	16-25	101
07:00	53	117	47	89	42	0	0	0	0	0	0	0	0	2	350	16-25	164
08:00	73	98	36	97	43	7	1	0	0	0	0	0	0	0	355	26-35	140
09:00	56	116	37	111	84	14	0	0	0	1	0	0	0	0	419	26-35	195
10:00	56	148	35	101	61	12	2	0	0	1	0	0	0	0	416	16-25	183
11:00	67	150	32	116	71	9	1	0	0	0	0	0	0	0	446	26-35	187
12 PM	44	168	41	118	84	14	0	1	1	0	0	0	0	0	471	16-25	209
13:00	49	161	19	105	86	9	1	0	0	0	0	0	0	0	430	26-35	191
14:00	78	163	60	104	103	6	0	0	0	0	0	0	0	1	515	16-25	223
15:00	99	177	63	100	102	10	0	0	0	0	0	0	0	0	551	16-25	240
16:00	83	154	60	119	94	8	2	0	0	0	0	0	0	1	521	16-25	214
17:00	69	171	61	125	79	10	0	1	1	0	1	0	0	2	520	16-25	232
18:00	51	138	37	106	75	10	2	0	1	0	0	0	0	0	420	26-35	181
19:00	22	113	30	69	58	8	0	0	0	0	0	0	0	1	301	16-25	143
20:00	19	92	29	86	61	10	2	0	0	0	0	0	0	0	299	26-35	147
21:00	18	69	21	37	41	5	1	0	0	0	0	0	0	0	192	16-25	90
22:00	11	70	18	41	41	8	0	0	0	0	0	0	0	1	190	16-25	88
23:00	5	43	9	28	27	3	1	0	0	0	0	0	0	0	116	26-35	55
Total	906	2349	684	1689	1252	160	18	2	4	2	1	0	0	8	7075		
Percent	12.8%	33.2%	9.7%	23.9%	17.7%	2.3%	0.3%	0.0%	0.1%	0.0%	0.0%	0.0%	0.0%	0.1%			
AM Peak	08:00	11:00	07:00	11:00	09:00	09:00	03:00		05:00	09:00				07:00	11:00		
Vol.	73	150	47	116	84	14	2		1	1				2	446		
PM Peak	15:00	15:00	15:00	17:00	14:00	12:00	16:00	12:00	12:00		17:00			17:00	15:00		
Vol.	99	177	63	125	103	14	2	1	1		1			2	551		

Site Code: 16
ST JOHNS BLVD N.O N.O 33RD ST

NB	Start Time	15	16	20	21	25	26	30	31	35	36	40	41	45	46	50	51	55	56	60	61	65	66	70	71	75	76	999	Total	Pace Speed	Number in Pace
12/16/23	7	19	4	13	17	2	1	0	0	0	0	0	0	0	0	0	0	0	0	0	0	0	0	0	0	0	0	63	26-35	30	
01:00	1	15	6	13	6	2	1	0	0	0	0	0	0	0	0	0	0	0	0	0	0	0	0	0	0	0	0	44	16-25	21	
02:00	3	13	2	9	13	2	0	0	0	0	0	0	0	0	0	0	0	0	0	0	0	0	0	0	0	0	42	26-35	22		
03:00	1	6	3	8	6	0	0	0	0	0	0	0	0	0	0	0	0	0	0	0	0	0	0	0	0	0	24	26-35	14		
04:00	1	9	2	5	8	1	1	0	0	0	0	0	0	0	0	0	0	0	0	0	0	0	0	0	0	0	27	26-35	13		
05:00	5	21	5	12	14	3	0	0	0	0	0	0	0	0	0	0	0	0	0	0	0	0	0	0	0	0	60	16-25	26		
06:00	2	23	13	23	20	6	0	0	0	0	0	0	0	0	0	0	0	0	0	0	0	0	0	0	0	0	87	26-35	43		
07:00	17	40	13	24	26	6	0	0	0	0	0	0	0	0	0	0	0	0	0	0	0	0	0	0	0	0	126	16-25	53		
08:00	16	70	12	52	41	6	1	0	0	0	0	0	0	0	0	0	0	0	0	0	0	0	0	0	0	0	198	26-35	93		
09:00	28	118	25	95	73	13	1	0	0	0	0	0	0	0	0	0	0	0	0	0	0	0	0	0	0	0	353	26-35	168		
10:00	41	158	24	86	76	14	1	0	0	0	0	0	0	0	0	0	0	0	0	0	0	0	0	0	0	0	400	16-25	182		
11:00	39	161	29	86	90	10	0	0	0	0	0	0	0	0	0	0	0	0	0	0	0	0	0	0	0	0	415	16-25	190		
12 PM	29	163	34	112	87	7	0	0	0	0	0	0	0	0	0	0	0	0	0	0	0	0	0	0	0	0	432	26-35	199		
13:00	48	146	31	102	70	5	1	0	0	0	1	0	0	0	0	0	0	0	0	0	0	0	0	0	0	1	405	16-25	177		
14:00	54	139	38	96	78	18	0	0	0	0	0	0	0	0	0	0	0	0	0	0	0	0	0	0	0	0	423	16-25	177		
15:00	47	173	36	88	68	12	1	1	0	0	0	0	0	0	0	0	0	0	0	0	0	0	0	0	0	0	426	16-25	209		
16:00	50	144	36	104	100	2	1	0	0	0	0	0	0	0	0	0	0	0	0	0	0	0	0	0	0	0	437	26-35	204		
17:00	45	127	32	95	69	12	1	1	0	0	1	1	0	0	0	1	0	0	0	0	0	0	0	0	0	0	384	26-35	164		
18:00	38	123	25	72	50	5	1	0	0	0	0	0	0	0	0	0	0	0	0	0	0	0	0	0	0	1	315	16-25	148		
19:00	20	117	19	77	57	11	0	0	0	0	0	0	0	0	0	0	0	0	0	0	0	0	0	0	0	0	302	16-25	136		
20:00	27	65	24	63	49	6	1	0	0	0	0	0	0	0	0	0	0	0	0	0	0	0	0	0	0	0	235	26-35	112		
21:00	16	78	26	46	28	5	0	0	0	0	0	0	0	0	0	0	0	0	0	0	0	0	0	0	0	0	199	16-25	104		
22:00	11	51	23	41	24	3	1	0	0	0	0	0	0	0	0	0	0	0	0	0	0	0	0	0	0	0	154	16-25	74		
23:00	6	29	14	31	28	5	2	0	0	0	0	0	0	0	0	0	0	0	0	0	0	0	0	0	0	0	115	26-35	59		
Total	552	2008	476	1353	1098	156	15	2	0	2	2	2	0	0	0	0	0	0	0	0	0	0	0	0	0	2	5666				
Percent	9.7%	35.4%	8.4%	23.9%	19.4%	2.8%	0.3%	0.0%	0.0%	0.0%	0.0%	0.0%	0.0%	0.0%	0.0%	0.0%	0.0%	0.0%	0.0%	0.0%	0.0%	0.0%	0.0%	0.0%	0.0%	0.0%					
AM Peak	10:00	11:00	11:00	09:00	11:00	10:00	00:00																						11:00		
Vol.	41	161	29	95	90	14	1																					415			
PM Peak	14:00	15:00	14:00	12:00	16:00	14:00	23:00	15:00																				13:00	16:00		
Vol.	54	173	38	112	100	18	2	1																				437			
Total	2897	5899	1643	4296	3183	436	63	16	11	12	9	4	4	4	4	4	4	4	4	4	4	4	4	4	4	4	49	18522			
Percent	15.6%	31.8%	8.9%	23.2%	17.2%	2.4%	0.3%	0.1%	0.1%	0.1%	0.0%	0.0%	0.0%	0.0%	0.0%	0.0%	0.0%	0.0%	0.0%	0.0%	0.0%	0.0%	0.0%	0.0%	0.0%	0.0%	0.3%				

15th Percentile : 14 MPH
50th Percentile : 21 MPH
85th Percentile : 31 MPH
95th Percentile : 34 MPH

Stats
10 MPH Pace Speed : 16-25 MPH
Number in Pace : 7542
Percent in Pace : 40.7%
Number of Vehicles > 30 MPH : 3787
Percent of Vehicles > 30 MPH : 20.4%
Mean Speed(Average) : 22 MPH

All Traffic Data Services, LLC
www.alltrafficdata.net

Site Code: 16
ST JOHNS BLVD N.O N.O 33RD ST

SB

Start Time	1 15	16 20	21 25	26 30	31 35	36 40	41 45	46 50	51 55	56 60	61 65	66 70	71 75	76 999	Total	Pace Speed	Number in Pace
12/14/23	27	2	0	2	1	1	0	0	0	0	0	0	0	0	33	1-10	18
01:00	16	4	1	0	1	0	0	0	0	0	0	0	0	1	23	1-10	11
02:00	5	9	0	0	0	0	0	0	0	0	0	0	0	0	14	11-20	11
03:00	3	8	3	4	0	0	0	0	0	0	0	0	0	1	19	16-25	11
04:00	13	6	6	9	2	3	1	0	1	1	0	0	0	1	43	21-30	15
05:00	30	6	3	1	5	1	3	3	1	0	0	0	1	4	58	6-15	20
06:00	58	5	7	1	0	0	0	0	0	0	0	0	0	0	71	1-10	39
07:00	51	0	1	2	3	1	0	1	0	0	0	0	0	0	59	1-10	34
08:00	42	0	0	0	0	1	0	0	0	0	0	0	0	0	43	1-10	28
09:00	37	0	0	0	0	0	0	0	0	0	0	0	0	0	37	1-10	25
10:00	33	0	0	0	0	0	0	0	0	0	0	0	0	0	33	1-10	22
11:00	86	48	57	41	19	6	0	0	0	0	0	0	0	0	257	16-25	105
12 PM	105	63	69	90	53	2	0	0	0	0	0	0	0	0	382	21-30	159
13:00	91	59	95	90	53	11	0	1	0	0	0	0	0	0	400	21-30	185
14:00	101	53	77	70	40	8	1	0	0	0	0	0	0	1	351	21-30	147
15:00	107	47	73	67	31	13	0	0	0	0	0	0	0	0	338	21-30	140
16:00	114	33	53	37	22	7	2	0	0	0	0	0	0	3	271	21-30	90
17:00	117	59	65	57	29	7	0	0	0	0	0	0	0	0	334	16-25	124
18:00	91	48	98	69	39	2	0	0	0	0	1	0	0	0	348	21-30	167
19:00	30	43	87	85	32	5	1	1	0	0	0	0	0	0	284	21-30	172
20:00	14	31	71	68	29	6	2	0	0	0	0	0	0	0	221	21-30	139
21:00	9	16	52	69	31	4	1	0	0	0	0	0	0	0	182	21-30	121
22:00	0	12	38	46	26	1	0	0	0	0	0	0	0	0	123	21-30	84
23:00	2	1	24	40	18	1	2	0	0	0	0	0	0	0	88	21-30	64
Total	1182	553	880	848	434	80	13	6	2	1	1	0	1	11	4012		
Percent	29.5%	13.8%	21.9%	21.1%	10.8%	2.0%	0.3%	0.1%	0.0%	0.0%	0.0%	0.0%	0.0%	0.3%			
AM Peak	11:00	11:00	11:00	11:00	11:00	11:00	05:00	05:00	04:00	04:00			05:00	05:00	11:00		
Vol.	86	48	57	41	19	6	3	3	1	1			1	4	257		
PM Peak	17:00	12:00	18:00	12:00	12:00	15:00	16:00	13:00			18:00			16:00	13:00		
Vol.	117	63	98	90	53	13	2	1			1			3	400		

Site Code: 16
ST JOHNS BLVD N.O N.O 33RD ST

SB

Start Time	1	16	21	26	31	36	41	46	51	56	61	66	71	76	Total	Pace Speed	Number in Pace
	15	20	25	30	35	40	45	50	55	60	65	70	75	999			
12/15/23	1	2	9	29	13	2	2	0	0	0	0	0	0	0	58	26-35	42
01:00	0	0	8	11	8	1	0	1	0	0	0	0	0	0	29	21-30	19
02:00	0	1	8	6	2	2	1	0	0	0	0	0	0	0	20	21-30	14
03:00	0	0	3	6	7	2	2	0	0	0	0	0	0	0	20	26-35	13
04:00	0	3	9	18	12	2	0	0	0	0	0	0	0	0	44	26-35	30
05:00	3	9	29	43	19	10	3	1	0	0	0	0	0	0	117	21-30	72
06:00	25	24	53	87	97	18	4	1	0	0	0	0	0	0	309	26-35	184
07:00	106	65	107	100	54	8	0	1	0	0	0	0	0	1	442	21-30	207
08:00	113	66	89	88	35	9	2	0	0	0	0	0	0	0	402	21-30	177
09:00	69	47	91	113	73	11	3	1	0	0	0	0	0	1	409	21-30	204
10:00	56	50	77	84	36	10	1	0	0	0	0	0	0	0	314	21-30	161
11:00	89	50	83	86	36	14	1	0	0	0	0	0	0	0	359	21-30	169
12 PM	84	49	108	87	60	15	3	1	0	0	0	0	0	0	407	21-30	195
13:00	85	49	72	63	52	13	3	1	0	1	0	0	0	0	339	21-30	135
14:00	94	46	75	77	48	11	0	2	1	0	1	0	0	0	355	21-30	152
15:00	113	52	75	74	42	5	0	1	0	0	1	0	0	1	364	21-30	149
16:00	106	40	64	74	34	1	0	0	0	0	0	0	0	1	320	21-30	138
17:00	98	42	70	68	38	10	1	0	0	0	0	0	0	0	327	21-30	138
18:00	82	53	93	80	53	17	0	0	0	0	0	0	0	0	378	21-30	173
19:00	21	38	79	91	51	15	0	0	0	0	0	0	0	1	296	21-30	170
20:00	29	31	72	91	40	7	2	0	0	0	0	0	0	0	272	21-30	163
21:00	7	15	45	61	37	8	1	0	0	0	0	0	0	0	174	21-30	106
22:00	5	8	35	56	35	5	1	0	0	0	0	0	0	0	145	26-35	91
23:00	4	7	30	64	28	7	3	0	0	0	0	0	0	0	143	21-30	94
Total	1190	747	1384	1557	910	203	33	10	1	1	2	0	0	5	6043		
Percent	19.7%	12.4%	22.9%	25.8%	15.1%	3.4%	0.5%	0.2%	0.0%	0.0%	0.0%	0.0%	0.0%	0.1%			
AM Peak	08:00	08:00	07:00	09:00	06:00	06:00	06:00	01:00						07:00	07:00		
Vol.	113	66	107	113	97	18	4	1						1	442		
PM Peak	15:00	18:00	12:00	19:00	12:00	18:00	12:00	14:00	14:00	13:00	14:00			15:00	12:00		
Vol.	113	53	108	91	60	17	3	2	1	1	1			1	407		

Site Code: 16
ST JOHNS BLVD N.O N.O 33RD ST

SB	Start Time	1	16	21	26	31	36	41	46	51	56	61	66	71	76	Total	Pace Speed	Number in Pace
		15	20	25	30	35	40	45	50	55	60	65	70	75	999			
12/16/23		2	3	14	34	19	5	0	1	0	0	0	0	0	1	79	26-35	53
01:00		0	2	10	16	12	2	0	0	0	0	0	0	1	0	43	25-34	28
02:00		0	1	3	16	14	1	0	0	0	0	0	0	0	0	35	26-35	30
03:00		1	0	7	11	10	2	0	0	0	0	0	0	0	0	31	26-35	21
04:00		0	1	5	8	11	4	1	0	0	0	0	0	0	0	30	26-35	19
05:00		1	4	12	16	21	3	0	0	0	0	0	0	0	0	57	26-35	37
06:00		0	2	16	31	14	7	1	0	0	0	0	0	0	0	71	21-30	47
07:00		5	5	27	40	31	6	3	0	0	0	0	0	0	0	117	26-35	71
08:00		14	18	47	64	23	8	3	0	0	0	0	1	0	0	178	21-30	111
09:00		37	31	71	94	42	7	4	3	0	0	0	0	0	0	289	21-30	165
10:00		36	35	89	79	45	8	0	0	0	0	0	0	0	0	292	21-30	168
11:00		56	46	78	76	32	14	3	1	0	0	0	0	0	0	306	21-30	154
12 PM		60	53	79	87	49	16	5	1	0	0	0	0	0	1	351	21-30	166
13:00		83	50	58	86	36	8	1	0	0	0	0	0	0	0	322	21-30	144
14:00		79	47	74	110	65	8	1	0	0	0	0	0	0	2	386	21-30	184
15:00		71	54	75	88	40	10	2	0	0	0	0	0	0	0	340	21-30	163
16:00		74	54	96	79	50	14	2	0	0	1	0	0	0	0	370	21-30	175
17:00		51	45	82	109	60	10	2	0	0	0	0	0	0	0	359	21-30	191
18:00		44	35	76	103	39	12	3	0	0	0	0	0	0	0	312	21-30	179
19:00		30	25	97	86	44	7	1	0	0	0	0	0	0	0	290	21-30	183
20:00		13	28	71	82	31	13	1	2	0	0	0	0	0	0	241	21-30	153
21:00		8	21	76	70	24	8	0	0	0	0	0	0	0	0	207	21-30	146
22:00		6	14	48	61	29	6	0	0	0	0	0	0	0	0	164	21-30	109
23:00		1	7	35	54	24	6	2	0	0	0	0	0	0	0	129	21-30	89
Total		672	581	1246	1500	765	185	35	8	0	1	0	1	1	4	4999		
Percent		13.4%	11.6%	24.9%	30.0%	15.3%	3.7%	0.7%	0.2%	0.0%	0.0%	0.0%	0.0%	0.0%	0.1%			
AM Peak	11:00	11:00	10:00	09:00	10:00	11:00	09:00	09:00					08:00	01:00	00:00	11:00		
Vol.	56	46	89	94	45	14	4	3					1	1	1	306		
PM Peak	13:00	15:00	19:00	14:00	14:00	12:00	12:00	20:00			16:00				14:00	14:00		
Vol.	83	54	97	110	65	16	5	2			1				2	386		
Total	3044	1881	3510	3905	2109	468	81	24	3	3	3	1	2	20	15054			
Percent	20.2%	12.5%	23.3%	25.9%	14.0%	3.1%	0.5%	0.2%	0.0%	0.0%	0.0%	0.0%	0.0%	0.1%				

15th Percentile : 11 MPH
 50th Percentile : 23 MPH
 85th Percentile : 31 MPH
 95th Percentile : 34 MPH

Stats
 10 MPH Pace Speed : 21-30 MPH
 Number in Pace : 7415
 Percent in Pace : 49.3%
 Number of Vehicles > 30 MPH : 2714
 Percent of Vehicles > 30 MPH : 18.0%
 Mean Speed(Average) : 23 MPH

Site Code: 17
ST JAMES RD N.O PETTICOAT LN

SB

Start Time	15	16 20	21 25	26 30	31 35	36 40	41 45	46 50	51 55	56 60	61 65	66 70	71 75	76 999	Total	Pace Speed	Number in Pace
12/14/23	0	0	0	1	10	11	7	1	2	0	0	0	0	0	32	31-40	21
01:00	0	0	3	4	2	5	5	1	3	0	0	0	0	0	23	36-45	10
02:00	0	0	0	3	9	11	6	6	2	1	0	0	0	0	38	31-40	20
03:00	0	0	1	4	3	15	10	6	2	0	0	0	0	0	41	36-45	25
04:00	0	1	0	2	13	28	35	17	4	0	0	0	1	0	101	36-45	63
05:00	0	0	1	5	31	76	84	47	11	2	0	0	0	0	257	36-45	160
06:00	0	2	3	6	75	197	162	36	10	0	0	0	0	0	491	36-45	359
07:00	0	0	1	32	211	353	134	44	6	1	0	0	0	0	782	31-40	564
08:00	3	1	2	39	192	327	159	40	8	1	0	0	0	0	772	31-40	519
09:00	1	0	6	39	147	214	132	46	5	1	0	0	0	0	591	31-40	361
10:00	2	0	1	30	139	222	122	26	8	1	0	0	0	0	551	31-40	361
11:00	4	0	3	11	158	228	123	27	3	3	0	0	0	0	560	31-40	386
12 PM	1	0	4	32	151	224	125	49	4	2	0	0	0	0	592	31-40	375
13:00	0	0	5	32	141	231	143	30	4	1	0	0	0	0	587	36-45	374
14:00	3	0	4	33	159	263	121	37	6	2	0	0	0	0	628	31-40	422
15:00	1	0	4	40	167	265	167	42	7	3	0	0	0	0	696	31-40	432
16:00	3	1	4	29	165	262	152	44	5	1	0	0	0	0	666	31-40	427
17:00	3	2	2	29	133	242	160	32	10	2	0	0	0	0	615	36-45	402
18:00	1	0	1	31	169	193	86	25	2	0	0	0	0	0	508	31-40	362
19:00	0	1	2	15	71	102	79	20	2	0	1	0	0	0	293	36-45	181
20:00	1	1	6	9	45	112	51	15	7	0	1	0	0	0	248	36-45	163
21:00	0	0	2	13	46	77	44	9	3	0	0	0	0	0	194	31-40	123
22:00	0	0	2	4	29	42	22	3	1	0	0	0	0	0	103	31-40	71
23:00	0	0	1	4	23	21	20	7	2	0	0	0	0	0	78	31-40	44
Total	23	9	58	447	2289	3721	2149	610	117	21	2	0	1	0	9447		
Percent	0.2%	0.1%	0.6%	4.7%	24.2%	39.4%	22.7%	6.5%	1.2%	0.2%	0.0%	0.0%	0.0%	0.0%			
AM Peak	11:00	06:00	09:00	08:00	07:00	07:00	06:00	05:00	05:00	11:00			04:00		07:00		
Vol.	4	2	6	39	211	353	162	47	11	3			1		782		
PM Peak	14:00	17:00	20:00	15:00	18:00	15:00	15:00	12:00	17:00	15:00	19:00				15:00		
Vol.	3	2	6	40	169	265	167	49	10	3	1				696		

All Traffic Data Services, LLC
www.alltrafficdata.net

Site Code: 17
ST JAMES RD N.O PETTICOAT LN

SB

Start Time	15	16 20	21 25	26 30	31 35	36 40	41 45	46 50	51 55	56 60	61 65	66 70	71 75	76 999	Total	Pace Speed	Number in Pace
12/15/23	0	0	1	6	16	18	7	3	3	0	0	0	0	0	54	31-40	34
01:00	0	0	0	3	10	6	3	3	0	0	0	0	0	0	25	31-40	16
02:00	0	1	0	4	5	19	3	3	1	0	0	0	0	0	36	31-40	24
03:00	0	0	0	2	6	11	13	5	1	0	0	0	0	0	38	36-45	24
04:00	0	0	1	8	10	20	31	15	3	1	0	0	0	0	89	36-45	51
05:00	1	0	3	8	42	73	64	34	8	2	0	0	0	0	235	36-45	137
06:00	1	0	1	3	74	196	128	37	9	2	0	0	0	0	451	36-45	324
07:00	1	1	9	52	169	307	142	38	4	1	0	0	0	0	724	31-40	476
08:00	3	0	15	72	257	302	114	29	5	0	1	0	0	0	798	31-40	559
09:00	0	0	8	32	158	236	97	37	7	0	1	0	0	0	576	31-40	394
10:00	1	0	2	31	125	222	124	37	7	0	0	0	0	0	549	31-40	347
11:00	1	0	2	30	129	234	157	36	5	1	0	0	0	0	595	36-45	391
12 PM	2	0	2	20	138	243	136	54	8	1	0	0	0	0	604	31-40	381
13:00	3	1	10	27	159	233	115	26	3	1	0	0	0	0	578	31-40	392
14:00	2	1	7	28	133	239	150	29	8	1	0	0	0	0	598	36-45	389
15:00	3	3	12	58	171	284	151	40	9	2	1	0	0	0	734	31-40	455
16:00	3	1	4	29	216	287	129	30	7	1	0	0	0	0	707	31-40	503
17:00	2	0	5	31	117	278	136	32	4	1	0	0	0	0	606	36-45	414
18:00	2	0	0	8	107	211	152	42	13	0	0	0	0	0	535	36-45	363
19:00	0	1	4	11	72	114	84	33	5	0	0	0	0	0	324	36-45	198
20:00	1	0	1	7	70	144	74	18	4	0	0	0	0	0	319	36-45	218
21:00	0	0	2	6	55	89	64	17	5	0	0	0	0	0	238	36-45	153
22:00	0	0	0	4	30	71	38	9	0	0	0	0	0	0	152	36-45	109
23:00	0	0	2	3	26	32	24	12	0	0	0	0	0	0	99	31-40	58
Total	26	9	91	483	2295	3869	2136	619	119	14	3	0	0	0	9664		
Percent	0.3%	0.1%	0.9%	5.0%	23.7%	40.0%	22.1%	6.4%	1.2%	0.1%	0.0%	0.0%	0.0%	0.0%			
AM Peak	08:00	02:00	08:00	08:00	08:00	07:00	11:00	07:00	06:00	05:00	08:00				08:00		
Vol.	3	1	15	72	257	307	157	38	9	2	1				798		
PM Peak	13:00	15:00	15:00	15:00	16:00	16:00	18:00	12:00	18:00	15:00	15:00				15:00		
Vol.	3	3	12	58	216	287	152	54	13	2	1				734		

Site Code: 17
ST JAMES RD N.O PETTICOAT LN

SB	Start Time	15	20	25	30	35	40	45	50	55	60	65	70	75	999	Total	Pace Speed	Number in Pace
12/16/23		0	0	4	6	16	26	20	5	2	0	0	0	0	0	79	36-45	46
01:00		0	0	1	4	11	12	9	7	2	0	0	0	0	0	46	31-40	23
02:00		0	0	0	4	11	8	7	5	1	0	0	0	0	0	36	31-40	19
03:00		0	0	0	0	0	8	6	2	0	0	0	0	0	0	16	36-45	14
04:00		0	0	3	2	10	17	19	7	1	0	0	0	0	0	59	36-45	36
05:00		0	0	1	6	13	23	25	11	1	2	0	0	0	0	82	36-45	48
06:00		0	0	0	10	26	41	34	13	4	0	0	0	0	0	128	36-45	75
07:00		2	1	2	8	52	84	48	11	3	0	0	0	0	0	211	31-40	136
08:00		2	1	1	14	83	126	89	23	7	1	0	0	0	0	347	36-45	215
09:00		1	0	3	20	111	200	91	30	5	2	0	0	0	0	463	31-40	311
10:00		3	1	2	27	130	198	132	30	7	1	0	0	0	0	531	35-44	330
11:00		1	0	3	26	77	261	167	58	9	0	0	0	0	0	602	36-45	428
12 PM		2	2	2	24	136	243	127	37	8	2	0	0	0	0	583	31-40	379
13:00		0	0	1	31	111	202	152	39	3	0	0	0	0	0	539	36-45	354
14:00		2	2	4	24	122	189	145	39	11	0	0	0	0	0	538	36-45	334
15:00		1	0	1	7	118	188	129	36	18	3	0	0	0	0	501	36-45	317
16:00		2	0	6	38	112	215	109	32	8	2	0	0	0	0	524	31-40	327
17:00		0	0	2	16	100	189	118	29	2	0	0	0	0	0	456	36-45	307
18:00		1	0	0	15	63	140	82	37	4	1	0	0	0	0	343	36-45	222
19:00		1	0	4	10	49	128	69	14	8	2	0	0	0	1	286	36-45	197
20:00		2	0	2	6	45	88	67	25	5	0	0	0	0	0	240	36-45	155
21:00		0	0	2	12	42	76	43	11	2	0	0	0	0	0	188	34-43	119
22:00		0	1	4	7	45	59	34	10	0	0	0	0	0	0	160	31-40	104
23:00		0	0	2	4	35	56	25	5	2	0	0	0	0	0	129	31-40	91
Total		20	8	50	321	1518	2777	1747	516	113	16	0	0	0	1	7087		
Percent		0.3%	0.1%	0.7%	4.5%	21.4%	39.2%	24.7%	7.3%	1.6%	0.2%	0.0%	0.0%	0.0%	0.0%			
AM Peak	10:00	07:00	00:00	10:00	10:00	11:00	11:00	11:00	11:00	11:00	05:00					11:00		
Vol.	3	1	4	27	130	261	167	58	9	2						602		
PM Peak	12:00	12:00	16:00	16:00	12:00	12:00	13:00	13:00	15:00	15:00					19:00	12:00		
Vol.	2	2	6	38	136	243	152	39	18	3					1	583		
Total	69	26	199	1251	6102	10367	6032	1745	349	51	5	0	1	1	1	26198		
Percent	0.3%	0.1%	0.8%	4.8%	23.3%	39.6%	23.0%	6.7%	1.3%	0.2%	0.0%	0.0%	0.0%	0.0%	0.0%			

15th Percentile : 31 MPH
 50th Percentile : 37 MPH
 85th Percentile : 43 MPH
 95th Percentile : 47 MPH

Stats
 10 MPH Pace Speed : 31-40 MPH
 Number in Pace : 16469
 Percent in Pace : 62.9%
 Number of Vehicles > 40 MPH : 8184
 Percent of Vehicles > 40 MPH : 31.2%
 Mean Speed(Average) : 38 MPH

Site Code: 18
ST JOHNS RD N.O PETTICOAT LN

NB

Start Time	15	20	25	30	35	40	45	50	55	60	65	70	75	999	Total	Pace Speed	Number in Pace
12/14/23	0	0	1	1	10	17	19	11	3	0	0	0	0	0	62	36-45	36
01:00	0	0	1	1	4	19	11	11	1	2	0	0	0	0	50	36-45	30
02:00	0	0	0	1	4	14	8	4	0	0	0	0	0	0	31	36-45	22
03:00	0	0	0	0	5	8	8	4	1	0	0	0	0	0	26	36-45	16
04:00	0	0	1	0	5	9	14	2	5	0	0	0	0	0	36	36-45	23
05:00	0	0	0	1	6	36	46	16	3	0	0	0	0	0	108	36-45	82
06:00	0	1	3	4	27	73	77	38	13	1	0	0	0	0	237	36-45	150
07:00	1	0	3	7	46	130	144	43	12	3	0	0	0	0	389	36-45	274
08:00	0	0	3	5	80	210	170	58	15	0	0	0	0	0	541	36-45	380
09:00	1	0	5	11	76	154	144	54	8	3	0	0	0	0	456	36-45	298
10:00	1	1	1	11	48	186	166	42	3	0	1	0	0	0	460	36-45	352
11:00	2	0	0	6	57	242	164	74	11	4	0	0	0	0	560	36-45	406
12 PM	1	0	1	5	67	224	206	58	12	5	0	0	0	0	579	36-45	430
13:00	3	0	3	25	89	229	172	62	9	4	0	0	0	0	596	36-45	401
14:00	1	0	0	11	81	293	256	81	22	2	1	0	0	0	748	36-45	549
15:00	8	0	1	12	115	298	331	85	18	5	0	0	0	0	873	36-45	629
16:00	4	2	2	12	60	345	334	109	12	4	0	0	0	0	884	36-45	679
17:00	4	0	3	18	130	330	273	56	11	1	0	0	0	0	826	36-45	603
18:00	1	0	1	8	96	248	171	57	6	2	0	0	0	0	590	36-45	419
19:00	0	1	1	4	66	159	130	27	6	3	0	0	0	0	397	36-45	289
20:00	1	0	1	7	47	126	120	37	11	2	0	0	0	0	352	36-45	246
21:00	0	0	0	4	35	126	90	30	7	1	0	0	0	0	293	36-45	216
22:00	0	0	2	5	27	87	60	11	4	2	0	0	0	0	198	36-45	147
23:00	0	0	0	2	17	50	28	7	2	0	0	0	0	0	106	36-45	78
Total	28	5	33	161	1198	3613	3142	977	195	44	2	0	0	0	9398		
Percent	0.3%	0.1%	0.4%	1.7%	12.7%	38.4%	33.4%	10.4%	2.1%	0.5%	0.0%	0.0%	0.0%	0.0%			
AM Peak	11:00	06:00	09:00	09:00	08:00	11:00	08:00	11:00	08:00	11:00	10:00				11:00		
Vol.	2	1	5	11	80	242	170	74	15	4	1				560		
PM Peak	15:00	16:00	13:00	13:00	17:00	16:00	16:00	16:00	14:00	12:00	14:00				16:00		
Vol.	8	2	3	25	130	345	334	109	22	5	1				884		

Site Code: 18
ST JOHNS RD N.O PETTICOAT LN

NB

Start Time	15	20	25	30	35	40	45	50	55	60	65	70	75	999	Total	Pace Speed	Number in Pace
12/15/23	0	0	0	0	11	26	28	10	0	1	1	0	0	0	77	36-45	54
01:00	0	0	0	2	8	21	18	12	2	1	0	1	0	0	65	36-45	39
02:00	0	0	0	1	4	11	10	12	1	0	0	0	0	0	39	39-48	22
03:00	0	0	0	0	1	13	10	3	1	0	0	0	0	0	28	36-45	23
04:00	0	0	0	0	6	18	5	2	1	0	0	0	0	0	32	31-40	24
05:00	0	0	0	0	14	41	29	19	1	1	0	0	0	0	105	36-45	70
06:00	0	0	0	2	18	69	84	32	7	2	0	0	0	0	214	36-45	153
07:00	2	0	1	4	43	161	158	53	6	5	1	0	0	0	434	36-45	319
08:00	2	1	2	13	66	188	206	54	9	4	0	0	0	0	545	36-45	394
09:00	1	0	1	10	49	173	165	43	11	1	0	0	0	0	454	36-45	338
10:00	3	1	2	11	61	189	195	44	11	3	0	0	0	0	520	36-45	384
11:00	1	0	1	10	73	197	216	73	11	4	0	0	0	0	586	36-45	413
12 PM	3	0	3	3	66	209	224	65	14	1	1	1	0	0	590	36-45	433
13:00	3	0	3	11	59	241	210	62	12	1	1	0	0	1	604	36-45	451
14:00	5	0	2	17	97	266	221	86	17	3	1	0	0	0	715	36-45	487
15:00	7	1	4	50	141	299	267	77	17	1	0	0	0	0	864	36-45	566
16:00	1	1	3	34	107	344	301	95	14	4	0	0	0	0	904	36-45	645
17:00	2	0	1	11	128	337	252	50	12	1	0	0	0	0	794	36-45	589
18:00	5	0	2	14	77	264	203	62	5	2	1	0	0	0	635	36-45	467
19:00	0	0	2	12	50	162	160	55	7	1	1	0	0	0	450	36-45	322
20:00	1	0	3	10	54	187	155	39	11	4	1	0	0	0	465	36-45	342
21:00	3	0	0	3	23	102	108	44	5	2	1	0	0	0	291	36-45	210
22:00	0	0	0	3	26	95	94	35	8	1	0	0	0	0	262	36-45	189
23:00	1	0	1	2	13	72	55	15	5	0	0	0	1	0	165	36-45	127
Total	40	4	31	223	1195	3685	3374	1042	188	43	9	2	1	1	9838		
Percent	0.4%	0.0%	0.3%	2.3%	12.1%	37.5%	34.3%	10.6%	1.9%	0.4%	0.1%	0.0%	0.0%	0.0%			
AM Peak	10:00	08:00	08:00	08:00	11:00	11:00	11:00	11:00	09:00	07:00	00:00	01:00					11:00
Vol.	3	1	2	13	73	197	216	73	11	5	1	1					586
PM Peak	15:00	15:00	15:00	15:00	15:00	16:00	16:00	16:00	14:00	16:00	12:00	12:00	23:00	13:00	16:00		
Vol.	7	1	4	50	141	344	301	95	17	4	1	1	1	1	904		

Site Code: 18
ST JOHNS RD N.O PETTICOAT LN

NB	Start Time	15	16 20	21 25	26 30	31 35	36 40	41 45	46 50	51 55	56 60	61 65	66 70	71 75	76 999	Total	Pace Speed	Number in Pace
12/16/23		0	0	0	3	12	26	30	7	3	0	0	0	0	0	81	36-45	56
01:00		0	0	0	1	9	19	21	9	3	0	0	0	0	0	62	36-45	40
02:00		0	0	0	3	8	19	16	6	3	1	0	0	0	0	56	36-45	35
03:00		0	0	0	4	2	6	12	1	1	0	0	0	0	0	26	36-45	18
04:00		0	0	1	0	5	7	11	2	1	0	0	0	0	0	27	36-45	18
05:00		0	0	1	1	4	16	13	7	3	3	0	0	0	0	48	36-45	29
06:00		1	0	0	5	12	26	27	16	7	3	0	0	0	0	97	36-45	53
07:00		1	0	0	2	15	54	50	17	4	1	0	0	0	0	144	36-45	104
08:00		1	0	0	1	23	84	81	42	8	2	1	0	0	0	243	36-45	165
09:00		0	0	2	1	39	134	148	59	9	1	1	0	0	0	394	36-45	282
10:00		0	0	1	5	47	189	178	54	11	1	0	0	0	0	486	36-45	367
11:00		1	0	1	9	53	178	151	66	13	1	0	0	0	0	473	36-45	329
12 PM		3	0	1	11	62	166	167	54	6	0	1	0	0	0	471	36-45	333
13:00		2	0	0	23	64	188	193	71	15	4	1	0	0	0	561	36-45	381
14:00		2	1	4	9	66	210	180	71	17	1	0	0	0	0	561	36-45	390
15:00		1	0	2	11	49	222	228	80	15	7	0	0	0	0	615	36-45	450
16:00		1	0	0	11	62	227	214	68	15	2	0	0	0	0	600	36-45	441
17:00		1	1	0	4	86	235	172	46	10	2	1	0	0	0	558	36-45	407
18:00		0	0	0	9	52	169	149	50	15	4	0	0	0	0	448	36-45	318
19:00		0	0	1	6	39	145	130	62	16	0	1	0	0	0	400	36-45	275
20:00		1	0	2	7	37	113	120	39	3	1	0	0	0	0	323	36-45	233
21:00		0	0	0	4	34	98	90	29	12	1	0	0	0	0	268	36-45	188
22:00		2	0	0	5	17	75	96	29	8	2	0	1	0	0	235	36-45	171
23:00		0	0	0	0	8	67	66	19	10	2	0	0	0	0	172	36-45	133
Total		17	2	16	135	805	2673	2543	904	208	39	6	1	0	0	7349		
Percent		0.2%	0.0%	0.2%	1.8%	11.0%	36.4%	34.6%	12.3%	2.8%	0.5%	0.1%	0.0%	0.0%	0.0%			
AM Peak	06:00			09:00	11:00	11:00	10:00	10:00	11:00	11:00	05:00	08:00				10:00		
Vol.	1			2	9	53	189	178	66	13	3	1				486		
PM Peak	12:00	14:00	14:00	13:00	17:00	17:00	17:00	15:00	15:00	14:00	15:00	12:00	22:00			15:00		
Vol.	3	1	4	23	86	235	228	80	17	7	1	1			615			
Total	85	11	80	519	3198	9971	9059	2923	591	126	17	3	1	1	26585			
Percent	0.3%	0.0%	0.3%	2.0%	12.0%	37.5%	34.1%	11.0%	2.2%	0.5%	0.1%	0.0%	0.0%	0.0%				

15th Percentile : 35 MPH
50th Percentile : 39 MPH
85th Percentile : 44 MPH
95th Percentile : 48 MPH

Stats
10 MPH Pace Speed : 36-45 MPH
Number in Pace : 19030
Percent in Pace : 71.6%
Number of Vehicles > 40 MPH : 12721
Percent of Vehicles > 40 MPH : 47.9%
Mean Speed(Average) : 40 MPH

All Traffic Data Services, LLC
www.alltrafficdata.net

Site Code: 19
ST JAMES RD N.O 49TH ST

SB

Start Time	15	20	25	30	35	40	45	50	55	60	65	70	75	999	Total	Pace Speed	Number in Pace
12/14/23	0	1	5	7	4	16	3	2	0	0	0	0	0	0	38	31-40	20
01:00	0	0	3	2	6	4	3	2	1	0	0	0	0	0	21	30-39	10
02:00	0	0	1	5	8	8	7	1	0	0	0	0	0	0	30	31-40	16
03:00	0	0	1	2	5	11	8	3	0	0	0	0	0	0	30	36-45	19
04:00	0	1	3	7	19	39	15	6	1	0	0	0	0	0	91	31-40	58
05:00	2	8	7	11	32	59	35	14	4	0	1	1	0	0	174	36-45	94
06:00	8	16	26	28	84	114	60	14	2	0	0	0	0	0	352	31-40	198
07:00	58	57	57	60	88	172	100	21	2	0	0	0	0	0	615	36-45	272
08:00	47	47	60	76	95	144	86	23	3	0	0	0	0	0	581	31-40	239
09:00	10	37	48	75	136	160	53	11	4	0	0	0	0	0	534	31-40	296
10:00	37	46	53	52	123	117	43	10	1	1	0	0	0	0	483	31-40	240
11:00	56	52	48	58	125	145	39	12	4	0	0	0	0	0	539	31-40	270
12 PM	38	44	53	75	130	151	59	8	3	0	0	0	0	0	561	31-40	281
13:00	47	56	62	63	127	132	58	8	4	0	0	0	0	0	557	31-40	259
14:00	62	46	72	83	153	141	35	7	0	0	0	0	0	0	599	31-40	294
15:00	64	81	72	74	124	130	60	7	4	1	0	0	0	0	617	31-40	254
16:00	92	62	67	79	122	147	39	9	0	2	0	0	0	0	619	31-40	269
17:00	48	65	55	85	122	134	33	10	1	0	0	0	0	0	553	31-40	256
18:00	33	38	45	67	113	131	35	6	0	0	0	0	0	0	468	31-40	244
19:00	6	15	28	39	79	87	24	3	4	0	0	0	0	0	285	31-40	166
20:00	5	11	29	31	62	66	25	7	0	0	0	0	0	0	236	31-40	128
21:00	3	10	16	18	47	57	20	4	2	0	0	0	0	0	177	31-40	104
22:00	4	3	14	17	26	30	9	1	1	0	0	0	0	0	105	31-40	56
23:00	0	0	7	10	15	24	11	4	0	0	0	0	0	0	71	31-40	39
Total	620	696	832	1024	1845	2219	860	193	41	4	1	1	0	0	8336		
Percent	7.4%	8.3%	10.0%	12.3%	22.1%	26.6%	10.3%	2.3%	0.5%	0.0%	0.0%	0.0%	0.0%	0.0%			
AM Peak	07:00	07:00	08:00	08:00	09:00	07:00	07:00	08:00	05:00	10:00	05:00	05:00				07:00	
Vol.	58	57	60	76	136	172	100	23	4	1	1	1			615		
PM Peak	16:00	15:00	14:00	17:00	14:00	12:00	15:00	17:00	13:00	16:00						16:00	
Vol.	92	81	72	85	153	151	60	10	4	2					619		

All Traffic Data Services, LLC
www.alltrafficdata.net

Site Code: 19
ST JAMES RD N.O 49TH ST

SB

Start Time	1	16	21	26	31	36	41	46	51	56	61	66	71	76	Total	Pace Speed	Number in Pace
	15	20	25	30	35	40	45	50	55	60	65	70	75	999			
12/15/23	0	0	4	6	14	22	5	3	0	0	0	0	0	0	54	31-40	36
01:00	0	3	2	5	6	4	0	1	0	0	0	0	0	0	21	26-35	11
02:00	0	2	3	4	8	10	2	2	0	0	0	0	0	0	31	31-40	18
03:00	0	0	0	5	10	7	4	3	0	0	0	0	0	0	29	30-39	17
04:00	0	0	3	7	19	27	16	1	0	0	0	0	0	0	73	31-40	46
05:00	1	7	6	17	31	52	36	13	4	0	0	0	0	0	167	36-45	88
06:00	14	20	21	24	57	134	60	13	3	1	1	0	0	0	348	36-45	194
07:00	56	54	65	67	123	154	63	11	2	0	0	0	0	0	595	31-40	277
08:00	75	79	43	96	133	108	55	8	0	0	0	0	0	0	597	31-40	241
09:00	34	49	47	55	120	109	45	9	4	1	0	0	0	0	473	31-40	229
10:00	39	59	42	59	85	119	40	7	2	0	0	0	0	0	452	31-40	204
11:00	31	51	66	73	130	166	50	12	1	0	0	0	0	0	580	31-40	296
12 PM	33	47	54	65	135	167	58	9	3	0	0	0	0	0	571	31-40	302
13:00	33	52	70	68	118	148	49	6	1	1	0	0	0	0	546	31-40	266
14:00	48	73	70	111	126	119	44	11	1	0	0	0	0	0	603	31-40	245
15:00	80	81	68	78	114	127	56	5	0	0	0	0	0	0	609	31-40	241
16:00	68	69	112	95	137	134	51	9	3	0	0	0	0	0	678	31-40	271
17:00	45	46	64	87	123	151	43	6	2	0	0	0	0	0	567	31-40	274
18:00	23	46	59	77	151	123	32	8	0	0	0	0	0	0	519	31-40	274
19:00	7	20	49	43	80	86	29	4	2	0	0	0	0	0	320	31-40	166
20:00	8	24	34	41	69	94	28	2	2	0	0	0	0	0	302	31-40	163
21:00	6	13	26	29	48	72	14	3	2	0	0	0	0	0	213	31-40	120
22:00	1	7	10	18	37	41	21	5	0	0	0	0	0	0	140	31-40	78
23:00	0	2	5	7	24	28	14	3	1	0	0	0	0	0	84	31-40	52
Total	602	804	923	1137	1898	2202	815	154	33	3	1	0	0	0	8572		
Percent	7.0%	9.4%	10.8%	13.3%	22.1%	25.7%	9.5%	1.8%	0.4%	0.0%	0.0%	0.0%	0.0%	0.0%			
AM Peak	08:00	08:00	11:00	08:00	08:00	11:00	07:00	05:00	05:00	06:00	06:00				08:00		
Vol.	75	79	66	96	133	166	63	13	4	1	1				597		
PM Peak	15:00	15:00	16:00	14:00	18:00	12:00	12:00	14:00	12:00	13:00					16:00		
Vol.	80	81	112	111	151	167	58	11	3	1					678		

Site Code: 19
ST JAMES RD N.O 49TH ST

SB

Start Time	1	16	21	26	31	36	41	46	51	56	61	66	71	76	Total	Pace Speed	Number in Pace
	15	20	25	30	35	40	45	50	55	60	65	70	75	999			
12/16/23	0	0	9	5	20	22	13	2	0	0	0	0	0	0	71	31-40	42
01:00	0	1	6	9	5	14	2	3	0	0	0	0	0	0	40	31-40	19
02:00	0	0	3	2	6	10	5	1	1	0	1	0	0	0	29	31-40	16
03:00	0	0	1	5	2	6	3	1	0	0	0	0	0	0	18	34-43	9
04:00	0	0	2	2	10	17	14	2	0	0	0	0	0	0	47	36-45	31
05:00	0	0	4	5	14	20	5	3	1	0	1	0	0	0	53	31-40	34
06:00	0	1	6	13	31	28	12	5	1	0	0	0	0	0	97	31-40	59
07:00	2	5	13	17	40	51	17	10	2	0	0	0	0	0	157	31-40	91
08:00	12	14	39	38	72	68	34	11	1	0	0	0	0	0	289	31-40	140
09:00	14	24	44	59	84	115	34	8	2	0	0	0	0	0	384	31-40	199
10:00	35	60	58	67	100	87	52	4	3	0	0	0	0	0	466	31-40	187
11:00	48	64	40	58	101	117	50	3	3	1	0	0	0	0	485	31-40	218
12 PM	27	49	64	63	105	122	59	10	0	0	0	0	0	0	499	31-40	227
13:00	33	60	62	75	100	138	41	7	0	0	0	0	0	0	516	31-40	238
14:00	47	64	58	64	92	114	29	9	1	1	0	0	0	0	479	31-40	206
15:00	35	47	66	73	91	101	29	7	1	0	0	0	0	0	450	31-40	192
16:00	27	46	56	51	107	95	38	11	0	0	0	0	0	0	431	31-40	202
17:00	9	23	73	65	119	108	31	10	0	0	0	0	0	0	438	31-40	227
18:00	8	17	33	45	85	84	38	10	4	0	0	0	0	0	324	31-40	169
19:00	6	15	35	40	80	64	25	4	2	0	1	0	0	0	272	31-40	144
20:00	5	9	35	30	56	54	24	9	1	0	0	0	0	0	223	31-40	110
21:00	1	12	22	22	55	38	20	2	0	1	0	0	0	0	173	31-40	93
22:00	1	5	18	23	48	38	15	2	0	0	0	0	0	0	150	31-40	86
23:00	0	4	10	10	36	30	7	5	0	1	0	0	0	0	103	31-40	66
Total	310	520	757	841	1459	1541	597	139	23	4	3	0	0	0	6194		
Percent	5.0%	8.4%	12.2%	13.6%	23.6%	24.9%	9.6%	2.2%	0.4%	0.1%	0.0%	0.0%	0.0%	0.0%			
AM Peak	11:00	11:00	10:00	10:00	11:00	11:00	10:00	08:00	10:00	11:00	02:00				11:00		
Vol.	48	64	58	67	101	117	52	11	3	1	1				485		
PM Peak	14:00	14:00	17:00	13:00	17:00	13:00	12:00	16:00	18:00	14:00	19:00				13:00		
Vol.	47	64	73	75	119	138	59	11	4	1	1				516		
Total	1532	2020	2512	3002	5202	5962	2272	486	97	11	5	1	0	0	23102		
Percent	6.6%	8.7%	10.9%	13.0%	22.5%	25.8%	9.8%	2.1%	0.4%	0.0%	0.0%	0.0%	0.0%	0.0%			

15th Percentile : 19 MPH
50th Percentile : 32 MPH
85th Percentile : 39 MPH
95th Percentile : 43 MPH

Stats
10 MPH Pace Speed : 31-40 MPH
Number in Pace : 11164
Percent in Pace : 48.3%
Number of Vehicles > 35 MPH : 8834
Percent of Vehicles > 35 MPH : 38.2%
Mean Speed(Average) : 31 MPH

All Traffic Data Services, LLC
www.alltrafficdata.net

Site Code: 20
ST JOHNS RD N.O 49TH ST

NB

Start Time	15	20	25	30	35	40	45	50	55	60	65	70	75	999	Total	Pace Speed	Number in Pace
12/14/23	0	3	2	4	8	16	4	3	1	0	0	0	0	0	41	31-40	24
01:00	0	0	2	0	8	8	9	5	0	0	0	0	0	0	32	36-45	17
02:00	0	1	1	4	6	7	3	3	1	0	0	0	0	0	26	31-40	13
03:00	0	1	0	0	6	6	5	1	1	0	0	0	0	0	20	31-40	12
04:00	0	0	2	2	7	14	6	1	3	0	1	0	0	0	36	31-40	21
05:00	1	2	1	3	25	34	16	7	1	0	0	0	0	0	90	31-40	59
06:00	0	3	6	30	57	91	37	12	1	0	0	0	0	0	237	31-40	148
07:00	9	5	10	73	143	110	33	8	3	1	0	0	0	0	395	31-40	253
08:00	13	9	26	99	144	137	49	5	1	0	0	0	0	0	483	31-40	281
09:00	8	3	19	61	163	116	40	9	2	0	0	0	0	0	421	31-40	279
10:00	14	7	12	87	153	131	40	5	0	0	0	0	0	0	449	31-40	284
11:00	8	4	27	92	202	139	45	5	0	1	0	0	0	0	523	31-40	341
12 PM	6	11	31	101	184	149	44	8	1	0	0	0	0	0	535	31-40	333
13:00	10	2	15	72	181	170	68	8	1	0	0	0	0	0	527	31-40	351
14:00	25	16	27	124	206	181	48	8	1	0	0	0	0	0	636	31-40	387
15:00	17	10	17	119	276	229	68	12	3	0	0	0	0	0	751	31-40	505
16:00	21	23	24	119	313	183	35	6	0	0	0	0	0	0	724	31-40	496
17:00	10	10	21	112	247	223	64	4	0	2	0	0	0	0	693	31-40	470
18:00	7	12	15	70	144	156	53	3	1	0	0	0	0	0	461	31-40	300
19:00	2	5	13	27	111	96	32	8	0	0	0	0	0	0	294	31-40	207
20:00	8	8	7	47	103	90	28	5	0	0	0	0	0	0	296	31-40	193
21:00	3	3	4	22	61	75	23	3	1	0	0	0	0	0	195	31-40	136
22:00	0	6	3	11	55	48	13	1	1	0	0	0	0	0	138	31-40	103
23:00	0	7	3	8	26	27	3	1	0	0	0	0	0	0	75	31-40	53
Total	162	151	288	1287	2829	2436	766	131	23	4	1	0	0	0	8078		
Percent	2.0%	1.9%	3.6%	15.9%	35.0%	30.2%	9.5%	1.6%	0.3%	0.0%	0.0%	0.0%	0.0%	0.0%			
AM Peak	10:00	08:00	11:00	08:00	11:00	11:00	08:00	06:00	04:00	07:00	04:00				11:00		
Vol.	14	9	27	99	202	139	49	12	3	1	1				523		
PM Peak	14:00	16:00	12:00	14:00	16:00	15:00	13:00	15:00	15:00	17:00					15:00		
Vol.	25	23	31	124	313	229	68	12	3	2					751		

Site Code: 20
ST JOHNS RD N.O 49TH ST

NB

Start Time	15	20	25	30	35	40	45	50	55	60	65	70	75	999	Total	Pace Speed	Number in Pace
12/15/23	0	1	3	5	18	9	10	2	1	0	0	0	0	0	49	31-40	27
01:00	0	2	4	5	10	12	4	0	0	0	0	0	0	0	37	31-40	22
02:00	0	0	2	0	8	11	0	2	2	0	0	0	0	0	25	31-40	19
03:00	0	0	0	4	5	9	0	2	0	0	0	0	0	0	20	31-40	14
04:00	1	0	2	1	7	11	5	1	0	1	0	0	0	0	29	31-40	18
05:00	0	1	1	7	23	27	15	8	0	0	0	0	0	0	82	31-40	50
06:00	3	1	6	18	51	71	28	6	6	0	0	0	0	0	190	31-40	122
07:00	5	7	20	71	138	107	36	16	2	2	0	0	0	0	404	31-40	245
08:00	8	8	14	86	173	152	55	12	3	0	0	0	0	0	511	31-40	325
09:00	9	4	14	73	145	136	53	8	1	0	0	0	0	0	443	31-40	281
10:00	6	5	16	59	176	144	57	14	1	0	0	0	0	0	478	31-40	320
11:00	4	8	16	72	164	171	62	10	0	0	0	0	0	0	507	31-40	335
12 PM	7	2	16	85	195	206	66	15	2	0	0	0	0	0	594	31-40	401
13:00	5	13	17	55	161	200	80	7	1	1	0	0	0	0	540	31-40	361
14:00	14	6	18	108	207	201	66	12	3	2	0	0	0	0	637	31-40	408
15:00	10	11	26	116	283	237	70	12	5	0	0	0	0	0	770	31-40	520
16:00	21	17	31	117	285	196	42	5	0	0	0	0	0	0	714	31-40	481
17:00	11	9	21	105	246	211	44	2	0	0	0	0	0	0	649	31-40	457
18:00	14	11	26	90	168	152	38	6	0	0	0	0	0	0	505	31-40	320
19:00	7	7	13	45	112	107	29	6	1	0	0	0	0	0	327	31-40	219
20:00	7	6	8	43	116	96	38	0	6	0	0	0	0	0	320	31-40	212
21:00	12	4	12	18	72	70	29	9	2	0	0	0	0	0	228	31-40	142
22:00	6	2	5	10	45	67	35	9	1	0	0	0	0	0	180	31-40	112
23:00	6	4	8	11	27	32	16	4	1	0	0	0	0	0	109	31-40	59
Total	156	129	299	1204	2835	2635	878	168	38	6	0	0	0	0	8348		
Percent	1.9%	1.5%	3.6%	14.4%	34.0%	31.6%	10.5%	2.0%	0.5%	0.1%	0.0%	0.0%	0.0%	0.0%			
AM Peak	09:00	08:00	07:00	08:00	10:00	11:00	11:00	07:00	06:00	07:00					08:00		
Vol.	9	8	20	86	176	171	62	16	6	2					511		
PM Peak	16:00	16:00	16:00	16:00	16:00	15:00	13:00	12:00	20:00	14:00					15:00		
Vol.	21	17	31	117	285	237	80	15	6	2					770		

Site Code: 20
ST JOHNS RD N.O 49TH ST

NB

Start Time	15	20	25	30	35	40	45	50	55	60	65	70	75	999	Total	Pace Speed	Number in Pace
12/16/23	0	1	1	3	23	28	14	2	2	0	0	0	0	0	74	31-40	51
01:00	0	0	1	4	9	21	2	3	0	1	0	0	0	0	41	31-40	30
02:00	1	1	1	1	8	8	9	0	0	0	1	0	0	0	30	34-43	17
03:00	1	0	2	2	8	4	2	0	1	0	0	0	0	0	20	30-39	12
04:00	0	1	2	4	4	5	4	0	1	0	0	0	0	0	21	29-38	9
05:00	2	2	1	6	8	12	6	3	0	0	0	0	0	0	40	31-40	20
06:00	3	7	3	11	20	18	15	5	1	2	0	0	0	0	85	31-40	38
07:00	3	1	6	13	46	41	16	5	1	0	0	0	0	0	132	31-40	87
08:00	10	6	6	34	70	73	22	12	3	0	0	0	0	0	236	31-40	143
09:00	7	10	10	46	107	117	39	10	1	1	0	0	0	0	348	31-40	224
10:00	12	2	18	59	146	110	52	11	3	1	0	0	0	0	414	31-40	256
11:00	10	3	17	40	132	143	59	16	1	0	0	0	0	0	421	31-40	275
12 PM	17	5	12	62	150	149	56	3	0	0	0	0	0	0	454	31-40	299
13:00	3	6	21	73	140	177	71	7	2	1	0	0	0	0	501	31-40	317
14:00	13	5	18	85	163	149	57	15	0	2	0	0	0	0	507	31-40	312
15:00	8	8	14	64	135	165	64	9	2	1	0	0	0	0	470	31-40	300
16:00	6	9	21	86	114	193	50	7	0	0	0	0	0	0	486	31-40	307
17:00	15	14	17	76	164	122	41	4	0	0	0	0	0	0	453	31-40	286
18:00	2	8	13	47	121	117	32	4	0	0	0	0	0	0	344	31-40	238
19:00	3	9	13	31	95	111	39	10	1	0	1	0	0	0	313	31-40	206
20:00	3	6	7	29	65	83	40	3	1	0	0	0	0	0	237	31-40	148
21:00	16	8	10	18	60	62	19	3	0	0	0	0	0	0	196	31-40	122
22:00	7	5	2	17	58	51	23	3	2	0	0	0	0	0	168	31-40	109
23:00	6	6	6	10	34	31	16	5	1	0	1	0	0	0	116	31-40	65
Total	148	123	222	821	1880	1990	748	140	23	9	3	0	0	0	6107		
Percent	2.4%	2.0%	3.6%	13.4%	30.8%	32.6%	12.2%	2.3%	0.4%	0.1%	0.0%	0.0%	0.0%	0.0%			
AM Peak	10:00	09:00	10:00	10:00	10:00	11:00	11:00	11:00	08:00	06:00	02:00				11:00		
Vol.	12	10	18	59	146	143	59	16	3	2	1				421		
PM Peak	12:00	17:00	13:00	16:00	17:00	16:00	13:00	14:00	13:00	14:00	19:00				14:00		
Vol.	17	14	21	86	164	193	71	15	2	2	1				507		
Total	466	403	809	3312	7544	7061	2392	439	84	19	4	0	0	0	22533		
Percent	2.1%	1.8%	3.6%	14.7%	33.5%	31.3%	10.6%	1.9%	0.4%	0.1%	0.0%	0.0%	0.0%	0.0%			

15th Percentile : 27 MPH
50th Percentile : 34 MPH
85th Percentile : 39 MPH
95th Percentile : 43 MPH

Stats
10 MPH Pace Speed : 31-40 MPH
Number in Pace : 14605
Percent in Pace : 64.8%
Number of Vehicles > 35 MPH : 9999
Percent of Vehicles > 35 MPH : 44.4%
Mean Speed(Average) : 34 MPH

All Traffic Data Services, LLC
www.alltrafficdata.net

Site Code: 21
ST JAMES RD N.O 59TH ST

SB

Start Time	15	20	25	30	35	40	45	50	55	60	65	70	75	999	Total	Pace Speed	Number in Pace
12/14/23	0	0	2	6	13	11	1	1	0	0	0	0	0	0	34	31-40	24
01:00	0	0	2	4	6	4	0	1	0	0	0	0	0	0	17	26-35	10
02:00	0	0	2	5	8	6	1	1	0	0	0	0	0	0	23	29-38	14
03:00	0	1	1	2	7	2	4	0	0	0	0	0	0	0	17	26-35	9
04:00	3	0	0	10	20	9	3	0	1	0	0	0	0	0	46	26-35	30
05:00	0	1	6	20	40	21	9	1	0	0	0	0	0	0	98	31-40	61
06:00	2	0	10	46	72	81	24	3	2	1	0	0	0	0	241	31-40	153
07:00	5	4	12	118	258	133	44	6	2	0	0	0	0	0	582	31-40	391
08:00	5	6	20	112	239	165	37	4	1	0	0	0	0	0	589	31-40	404
09:00	6	0	20	105	193	120	33	1	1	0	0	0	0	0	479	31-40	313
10:00	5	6	23	147	197	94	18	2	0	0	0	0	0	0	492	26-35	344
11:00	3	1	12	113	238	135	27	6	1	0	0	0	0	0	536	31-40	373
12 PM	6	4	21	118	223	137	51	10	0	0	0	0	0	0	570	31-40	360
13:00	7	0	14	105	224	127	41	13	0	0	0	0	0	0	531	31-40	351
14:00	7	2	18	128	300	135	35	4	0	0	0	0	0	0	629	31-40	435
15:00	3	2	15	142	297	175	49	9	4	2	0	0	0	0	698	31-40	472
16:00	11	2	19	154	320	183	57	10	1	0	0	0	0	0	757	31-40	503
17:00	3	3	12	111	242	133	47	6	0	0	0	0	0	0	557	31-40	375
18:00	0	2	14	96	217	103	12	2	0	0	0	0	0	0	446	31-40	320
19:00	1	0	6	66	136	61	16	1	0	0	0	0	0	0	287	26-35	202
20:00	1	1	8	60	101	47	8	1	0	0	0	0	0	0	227	26-35	161
21:00	0	1	3	44	72	39	10	2	0	0	0	0	0	0	171	26-35	116
22:00	0	0	7	30	45	19	3	1	1	0	0	0	0	0	106	26-35	75
23:00	4	1	1	19	25	17	7	0	0	0	0	0	0	0	74	26-35	44
Total	72	37	248	1761	3493	1957	537	85	14	3	0	0	0	0	8207		
Percent	0.9%	0.5%	3.0%	21.5%	42.6%	23.8%	6.5%	1.0%	0.2%	0.0%	0.0%	0.0%	0.0%	0.0%			
AM Peak	09:00	08:00	10:00	10:00	07:00	08:00	07:00	07:00	06:00	06:00					08:00		
Vol.	6	6	23	147	258	165	44	6	2	1					589		
PM Peak	16:00	12:00	12:00	16:00	16:00	16:00	16:00	13:00	15:00	15:00					16:00		
Vol.	11	4	21	154	320	183	57	13	4	2					757		

All Traffic Data Services, LLC
www.alltrafficdata.net

Site Code: 21
ST JAMES RD N.O 59TH ST

SB

Start Time	15	20	25	30	35	40	45	50	55	60	65	70	75	999	Total	Pace Speed	Number in Pace
12/15/23	1	1	2	16	12	11	1	0	0	0	0	0	0	0	44	26-35	28
01:00	0	1	1	3	6	2	1	0	0	0	0	0	0	0	14	26-35	9
02:00	1	0	3	3	8	3	0	1	0	0	0	0	0	0	19	26-35	11
03:00	0	0	1	6	4	3	0	2	0	0	0	0	0	0	16	26-35	10
04:00	0	0	2	11	13	8	1	0	0	0	0	0	0	0	35	26-35	24
05:00	0	1	6	15	37	21	6	5	0	0	0	0	0	0	91	31-40	58
06:00	0	0	10	37	91	73	18	3	1	0	0	0	0	0	233	31-40	164
07:00	1	6	6	110	228	125	49	8	2	0	0	0	0	0	535	31-40	353
08:00	6	1	19	128	218	146	42	4	1	0	0	0	0	0	565	31-40	364
09:00	8	1	16	97	165	142	35	10	1	2	0	0	0	0	477	31-40	307
10:00	4	0	15	60	215	98	40	14	2	0	0	1	0	0	449	31-40	313
11:00	10	3	12	114	222	148	47	12	1	1	0	0	0	0	570	31-40	370
12 PM	7	3	11	113	268	130	38	9	1	0	0	0	0	0	580	31-40	398
13:00	7	1	13	123	247	126	39	15	0	0	0	0	0	0	571	31-40	373
14:00	2	0	15	93	270	161	50	4	1	0	0	0	0	0	596	31-40	431
15:00	4	3	6	116	284	196	55	10	0	0	0	0	0	0	674	31-40	480
16:00	7	4	12	139	289	211	76	7	2	0	0	0	0	0	747	31-40	500
17:00	5	1	3	111	301	153	44	10	2	0	0	0	0	0	630	31-40	454
18:00	1	0	12	95	199	139	31	6	1	0	0	2	0	0	486	31-40	338
19:00	1	0	8	64	122	83	21	5	1	0	0	0	0	0	305	31-40	205
20:00	1	1	5	46	116	73	16	6	1	0	0	0	0	0	265	31-40	189
21:00	0	0	6	45	78	49	14	0	1	1	0	0	0	0	194	31-40	127
22:00	0	0	3	35	58	25	17	3	1	0	0	0	0	0	142	26-35	93
23:00	0	1	4	22	35	13	7	1	0	0	0	0	0	0	83	26-35	57
Total	66	28	191	1602	3486	2139	648	135	19	4	0	3	0	0	8321		
Percent	0.8%	0.3%	2.3%	19.3%	41.9%	25.7%	7.8%	1.6%	0.2%	0.0%	0.0%	0.0%	0.0%	0.0%			
AM Peak	11:00	07:00	08:00	08:00	07:00	11:00	07:00	10:00	07:00	09:00		10:00			11:00		
Vol.	10	6	19	128	228	148	49	14	2	2		1			570		
PM Peak	12:00	16:00	14:00	16:00	17:00	16:00	16:00	13:00	16:00	21:00		18:00			16:00		
Vol.	7	4	15	139	301	211	76	15	2	1		2			747		

Site Code: 21
ST JAMES RD N.O 59TH ST

SB

Start Time	1 15	16 20	21 25	26 30	31 35	36 40	41 45	46 50	51 55	56 60	61 65	66 70	71 75	76 999	Total	Pace Speed	Number in Pace
12/16/23	0	0	3	15	30	15	6	1	0	1	0	0	0	0	71	31-40	45
01:00	0	0	1	12	8	10	4	1	0	0	0	0	0	0	36	26-35	20
02:00	0	0	2	4	14	1	3	1	0	1	0	0	0	0	26	26-35	18
03:00	0	1	0	2	7	2	0	1	0	0	0	0	0	0	13	31-40	9
04:00	1	0	1	7	11	7	3	0	0	0	0	0	0	0	30	26-35	18
05:00	0	0	2	7	11	11	0	0	2	0	0	0	0	0	33	31-40	22
06:00	0	0	7	10	21	16	5	0	0	0	0	0	0	0	59	31-40	37
07:00	0	0	1	38	42	22	6	2	0	1	0	0	0	0	112	26-35	80
08:00	2	2	7	49	80	55	17	6	1	0	0	0	0	0	219	31-40	135
09:00	2	0	5	62	134	78	32	7	0	0	0	0	0	0	320	31-40	212
10:00	0	0	8	72	169	112	40	11	0	0	0	0	0	0	412	31-40	281
11:00	5	1	8	94	205	117	40	5	0	0	0	0	0	0	475	31-40	322
12 PM	0	2	9	106	201	123	42	5	0	0	0	0	0	0	488	31-40	324
13:00	1	0	16	91	238	106	42	5	2	0	0	0	0	0	501	31-40	344
14:00	3	3	5	78	227	109	39	7	0	0	0	0	0	0	471	31-40	336
15:00	1	2	6	81	189	113	43	8	2	0	0	1	0	0	446	31-40	302
16:00	4	0	28	157	169	70	32	3	0	0	0	0	0	0	463	26-35	326
17:00	3	4	29	128	206	68	15	1	0	0	1	0	0	0	455	26-35	334
18:00	0	0	7	50	142	71	20	8	1	0	0	0	0	0	299	31-40	213
19:00	2	2	2	58	142	61	12	3	1	0	0	0	0	0	283	31-40	203
20:00	0	0	5	38	89	54	14	6	2	0	0	0	0	0	208	31-40	143
21:00	1	0	4	31	73	36	12	4	1	0	0	0	0	0	162	31-40	109
22:00	2	1	5	33	59	27	12	3	0	0	0	0	0	0	142	26-35	92
23:00	1	0	3	18	39	18	4	1	0	0	0	0	0	0	84	28-37	57
Total	28	18	164	1241	2506	1302	443	89	12	3	1	1	0	0	5808		
Percent	0.5%	0.3%	2.8%	21.4%	43.1%	22.4%	7.6%	1.5%	0.2%	0.1%	0.0%	0.0%	0.0%	0.0%			
AM Peak	11:00	08:00	10:00	11:00	11:00	11:00	10:00	10:00	05:00	00:00					11:00		
Vol.	5	2	8	94	205	117	40	11	2	1					475		
PM Peak	16:00	17:00	17:00	16:00	13:00	12:00	15:00	15:00	13:00		17:00	15:00			13:00		
Vol.	4	4	29	157	238	123	43	8	2		1	1			501		
Total	166	83	603	4604	9485	5398	1628	309	45	10	1	4	0	0	22336		
Percent	0.7%	0.4%	2.7%	20.6%	42.5%	24.2%	7.3%	1.4%	0.2%	0.0%	0.0%	0.0%	0.0%	0.0%			

15th Percentile : 27 MPH
50th Percentile : 33 MPH
85th Percentile : 38 MPH
95th Percentile : 42 MPH

Stats
10 MPH Pace Speed : 31-40 MPH
Number in Pace : 14883
Percent in Pace : 66.6%
Number of Vehicles > 35 MPH : 7395
Percent of Vehicles > 35 MPH : 33.1%
Mean Speed(Average) : 34 MPH

Site Code: 22
ST JOHNS RD N.O 59TH ST

NB

Start Time	15	20	25	30	35	40	45	50	55	60	65	70	75	999	Total	Pace Speed	Number in Pace
12/14/23	0	1	1	5	4	11	4	0	0	0	0	0	0	0	26	36-45	15
01:00	0	0	2	3	5	7	5	0	0	0	0	0	0	0	22	36-45	12
02:00	0	0	1	0	4	10	5	1	0	0	0	0	0	0	21	34-43	15
03:00	0	2	1	2	2	7	4	1	0	0	0	0	0	0	19	35-44	11
04:00	0	1	0	4	13	8	8	1	0	0	0	0	0	0	35	31-40	21
05:00	0	0	2	6	27	26	17	4	0	0	0	0	0	0	82	31-40	53
06:00	1	4	10	22	77	91	31	9	2	0	0	0	0	0	247	31-40	168
07:00	2	9	22	55	120	119	31	5	0	0	0	0	0	0	363	31-40	239
08:00	5	15	37	68	212	139	43	6	0	0	0	0	0	0	525	31-40	351
09:00	3	5	19	54	170	149	37	12	0	0	0	0	0	0	449	31-40	319
10:00	2	10	26	62	201	130	33	5	0	0	0	0	0	0	469	31-40	331
11:00	5	7	25	62	185	162	31	4	1	0	0	0	0	0	482	31-40	347
12 PM	7	14	27	72	178	175	41	8	0	0	0	0	0	0	522	31-40	353
13:00	4	9	38	72	181	190	48	4	0	0	0	0	0	1	547	31-40	371
14:00	12	19	52	114	234	169	28	4	2	0	0	0	0	0	634	31-40	403
15:00	13	15	42	108	264	227	52	6	1	1	1	0	0	0	730	31-40	491
16:00	11	21	51	129	263	176	43	7	2	1	0	0	0	0	704	31-40	439
17:00	3	25	55	126	229	178	30	6	2	0	0	0	0	0	654	31-40	407
18:00	2	19	26	50	196	107	21	2	0	0	0	0	0	0	423	31-40	303
19:00	2	18	21	47	110	73	21	1	1	1	0	0	0	0	295	31-40	183
20:00	1	8	18	39	103	70	14	1	0	0	0	0	0	0	254	31-40	173
21:00	0	9	6	26	59	44	6	2	0	0	0	0	0	0	152	31-40	103
22:00	1	6	3	11	40	31	9	0	0	0	0	0	0	0	101	31-40	71
23:00	0	1	7	8	21	13	3	0	0	0	0	0	0	0	53	31-40	34
Total	74	218	492	1145	2898	2312	565	89	11	3	1	0	0	1	7809		
Percent	0.9%	2.8%	6.3%	14.7%	37.1%	29.6%	7.2%	1.1%	0.1%	0.0%	0.0%	0.0%	0.0%	0.0%			
AM Peak	08:00	08:00	08:00	08:00	08:00	11:00	08:00	09:00	06:00								08:00
Vol.	5	15	37	68	212	162	43	12	2								525
PM Peak	15:00	17:00	17:00	16:00	15:00	15:00	15:00	12:00	14:00	15:00	15:00				13:00		15:00
Vol.	13	25	55	129	264	227	52	8	2	1	1			1			730

All Traffic Data Services, LLC
www.alltrafficdata.net

Site Code: 22
ST JOHNS RD N.O 59TH ST

NB

Start Time	15	20	25	30	35	40	45	50	55	60	65	70	75	999	Total	Pace Speed	Number in Pace
12/15/23	0	2	5	2	12	14	7	0	0	0	0	0	0	0	42	31-40	26
01:00	0	1	1	4	19	8	2	0	1	0	0	0	0	0	36	31-40	27
02:00	0	0	2	1	3	7	6	1	0	0	0	0	0	0	20	36-45	13
03:00	0	2	1	3	6	2	0	3	0	0	0	0	0	0	17	26-35	9
04:00	0	0	2	2	9	9	5	2	0	0	0	0	0	0	29	31-40	18
05:00	0	2	5	8	22	31	12	2	0	0	0	0	0	0	82	31-40	53
06:00	2	11	17	22	63	67	15	5	3	0	0	0	0	0	205	31-40	130
07:00	6	8	18	60	127	107	37	10	1	0	0	0	0	0	374	31-40	234
08:00	3	9	37	73	208	182	44	8	1	1	0	0	0	0	566	31-40	390
09:00	3	10	20	51	151	168	47	7	0	0	0	0	0	0	457	31-40	319
10:00	4	11	24	49	174	159	35	15	2	0	0	0	0	0	473	31-40	333
11:00	4	8	24	68	166	187	36	10	0	0	0	0	0	0	503	31-40	353
12 PM	2	14	31	85	233	195	50	1	2	0	0	0	0	0	613	31-40	428
13:00	3	10	33	61	215	178	38	3	1	0	0	0	0	0	542	31-40	393
14:00	5	13	20	70	254	193	43	5	1	0	0	0	0	0	604	31-40	447
15:00	4	20	42	94	295	243	52	12	0	0	0	0	0	0	762	31-40	538
16:00	8	30	57	115	250	205	45	7	1	0	0	0	0	0	718	31-40	455
17:00	3	23	33	111	255	164	41	3	0	0	0	0	0	0	633	31-40	419
18:00	2	34	24	73	176	124	33	5	0	0	0	0	0	0	471	31-40	300
19:00	3	16	24	31	81	106	24	4	0	0	0	0	0	0	289	31-40	187
20:00	1	10	23	29	109	87	18	7	0	0	0	0	0	0	284	31-40	196
21:00	1	7	12	22	55	73	21	12	1	0	0	0	0	0	204	31-40	128
22:00	0	5	12	17	37	57	12	5	2	0	0	0	0	0	147	31-40	94
23:00	0	2	4	10	26	22	11	1	1	0	0	0	0	0	77	31-40	48
Total	54	248	471	1061	2946	2588	634	128	17	1	0	0	0	0	8148		
Percent	0.7%	3.0%	5.8%	13.0%	36.2%	31.8%	7.8%	1.6%	0.2%	0.0%	0.0%	0.0%	0.0%	0.0%			
AM Peak	07:00	06:00	08:00	08:00	08:00	11:00	09:00	10:00	06:00	08:00					08:00		
Vol.	6	11	37	73	208	187	47	15	3	1					566		
PM Peak	16:00	18:00	16:00	16:00	15:00	15:00	15:00	15:00	12:00						15:00		
Vol.	8	34	57	115	295	243	52	12	2						762		

Site Code: 22
ST JOHNS RD N.O 59TH ST

NB	Start Time	15	20	25	30	35	40	45	50	55	60	65	70	75	76 999	Total	Pace Speed	Number in Pace
12/16/23		0	0	5	6	28	24	6	1	0	0	0	0	0	0	70	31-40	52
01:00		1	2	1	3	12	9	2	1	0	0	0	0	0	0	31	31-40	21
02:00		0	1	0	2	7	6	3	0	1	0	0	0	0	0	20	31-40	13
03:00		0	0	2	3	8	9	1	1	0	0	0	0	0	0	24	31-40	17
04:00		0	1	0	2	7	7	2	1	0	0	0	0	0	0	20	31-40	14
05:00		0	1	1	4	16	11	5	1	0	0	0	0	0	0	39	31-40	27
06:00		0	1	12	8	23	24	5	3	0	0	0	0	0	0	76	31-40	47
07:00		0	1	10	12	42	53	18	1	0	0	0	0	0	0	137	31-40	95
08:00		0	5	7	20	91	65	27	5	0	0	0	0	0	0	220	31-40	156
09:00		3	6	18	24	99	128	56	8	2	0	0	0	0	0	344	31-40	227
10:00		1	3	15	36	162	162	51	8	1	0	0	0	0	0	439	31-40	324
11:00		2	6	17	26	160	165	54	11	2	0	0	0	0	0	443	31-40	325
12 PM		4	6	19	46	162	190	56	3	0	0	0	0	0	0	486	31-40	352
13:00		2	10	18	45	160	178	48	8	4	0	0	0	0	0	473	31-40	338
14:00		1	9	19	53	168	196	43	4	1	1	0	0	0	0	495	31-40	364
15:00		2	6	19	44	149	175	68	11	2	0	0	0	0	0	476	31-40	324
16:00		4	7	22	46	183	147	36	4	0	0	0	0	0	0	449	31-40	330
17:00		2	15	32	55	170	123	34	3	0	0	0	0	0	0	434	31-40	293
18:00		2	10	16	29	143	84	26	0	0	0	0	0	0	0	310	31-40	227
19:00		2	12	26	35	93	79	25	6	0	0	0	0	0	0	278	31-40	172
20:00		2	7	13	20	78	70	24	1	0	1	0	0	0	0	216	31-40	148
21:00		0	8	15	19	42	52	13	4	1	0	0	0	0	0	154	31-40	94
22:00		0	6	6	12	45	42	19	3	0	0	0	0	0	0	133	31-40	87
23:00		0	3	7	8	34	20	9	3	1	0	0	0	0	0	85	31-40	54
Total		28	126	300	558	2082	2019	631	91	15	2	0	0	0	0	5852		
Percent		0.5%	2.2%	5.1%	9.5%	35.6%	34.5%	10.8%	1.6%	0.3%	0.0%	0.0%	0.0%	0.0%	0.0%			
AM Peak	09:00	09:00	09:00	10:00	10:00	11:00	11:00	09:00	11:00	09:00						11:00		
Vol.	3	6	18	36	162	165	56	11	2							443		
PM Peak	12:00	17:00	17:00	17:00	16:00	14:00	15:00	15:00	13:00	14:00						14:00		
Vol.	4	15	32	55	183	196	68	11	4	1						495		
Total	156	592	1263	2764	7926	6919	1830	308	43	6	1	0	0	1	21809			
Percent	0.7%	2.7%	5.8%	12.7%	36.3%	31.7%	8.4%	1.4%	0.2%	0.0%	0.0%	0.0%	0.0%	0.0%				

15th Percentile : 27 MPH
 50th Percentile : 33 MPH
 85th Percentile : 39 MPH
 95th Percentile : 42 MPH

Stats
 10 MPH Pace Speed : 31-40 MPH
 Number in Pace : 14845
 Percent in Pace : 68.1%
 Number of Vehicles > 35 MPH : 9108
 Percent of Vehicles > 35 MPH : 41.8%
 Mean Speed(Average) : 34 MPH